

National Semiconductor is now part of
Texas Instruments.

Search <http://www.ti.com/> for the latest technical
information and details on our current products and services.

LM113/LM313 Reference Diode

General Description

The LM113/LM313 are temperature compensated, low voltage reference diodes. They feature extremely-tight regulation over a wide range of operating currents in addition to an unusually-low breakdown voltage and good temperature stability.

The diodes are synthesized using transistors and resistors in a monolithic integrated circuit. As such, they have the same low noise and long term stability as modern IC op amps. Further, output voltage of the reference depends only on highly-predictable properties of components in the IC; so they can be manufactured and supplied to tight tolerances.

- Dynamic impedance of 0.3Ω from $500\mu\text{A}$ to 20mA
- Temperature stability typically 1% over -55°C to 125°C range (LM113), 0°C to 70°C (LM313)
- Tight tolerance: $\pm 5\%$, $\pm 2\%$ or $\pm 1\%$

The characteristics of this reference recommend it for use in bias-regulation circuitry, in low-voltage power supplies or in battery powered equipment. The fact that the breakdown voltage is equal to a physical property of silicon—the energy-band gap voltage—makes it useful for many temperature-compensation and temperature-measurement functions.

Features

- Low breakdown voltage: 1.220V

Schematic and Connection Diagrams

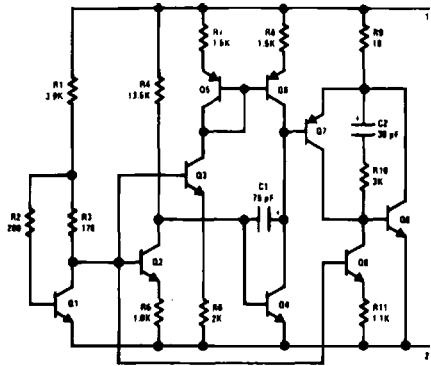

Metal Can Package

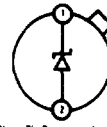

Note: Pin 2 connected to can.

TOP VIEW

Order Number

LM113H, LM113H/883,
LM113-1H, LM113-1H/883,
LM113-2H, LM113-2H/883,
or LM313H

See NS Package Number H02A

TL/H/5713-1

Typical Applications

Level Detector for Photodiode

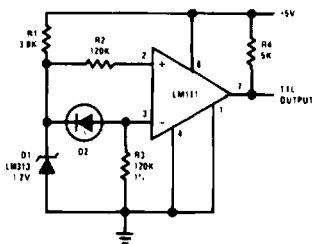

Low Voltage Regulator

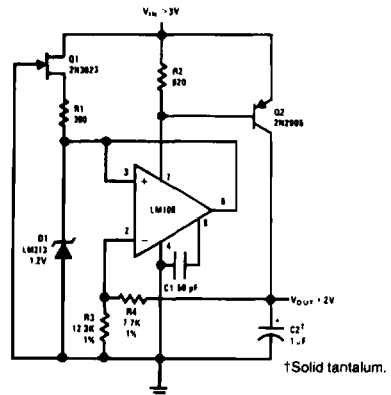

TL/H/5713-2

Absolute Maximum Ratings

If Military/Aerospace specified devices are required, please contact the National Semiconductor Sales Office/Distributors for availability and specifications. (Note 3)

Power Dissipation (Note 1)	100 mW
Reverse Current	50 mA
Forward Current	50 mA

Storage Temperature Range	-65°C to +150°C
Lead Temperature (Soldering, 10 seconds)	300°C
Operating Temperature Range LM113	-55°C to +125°C
LM313	0°C to +70°C

Electrical Characteristics (Note 2)

Parameter	Conditions	Min	Typ	Max	Units
Reverse Breakdown Voltage LM113/LM313 LM113-1 LM113-2	$I_R = 1 \text{ mA}$	1.160	1.220	1.280	V
		1.210	1.22	1.232	V
		1.195	1.22	1.245	V
Reverse Breakdown Voltage Change	$0.5 \text{ mA} \leq I_R \leq 20 \text{ mA}$		6.0	15	mV
Reverse Dynamic Impedance	$I_R = 1 \text{ mA}$ $I_R = 10 \text{ mA}$		0.2	1.0	Ω
			0.25	0.8	Ω
Forward Voltage Drop	$I_F = 1.0 \text{ mA}$		0.67	1.0	V
RMS Noise Voltage	$10 \text{ Hz} \leq f \leq 10 \text{ kHz}$ $I_R = 1 \text{ mA}$		5		μV
Reverse Breakdown Voltage Change with Current	$0.5 \text{ mA} \leq I_R \leq 10 \text{ mA}$ $T_{\text{MIN}} \leq T_A \leq T_{\text{MAX}}$			15	mV
Breakdown Voltage Temperature Coefficient	$1.0 \text{ mA} \leq I_R \leq 10 \text{ mA}$ $T_{\text{MIN}} \leq T_A \leq T_{\text{MAX}}$		0.01		%/°C

Note 1: For operating at elevated temperatures, the device must be derated based on a 150°C maximum junction and a thermal resistance of 80°C/W junction to case or 440°C/W junction to ambient.

Note 2: These specifications apply for $T_A = 25^\circ\text{C}$, unless stated otherwise. At high currents, breakdown voltage should be measured with lead lengths less than 1/4 inch. Kelvin contact sockets are also recommended. The diode should not be operated with shunt capacitances between 200 pF and 0.1 μF , unless isolated by at least a 100 Ω resistor, as it may oscillate at some currents.

Note 3: Refer to the following RETS drawings for military specifications: RETS113-1X for LM113-1, RETS113-2X for LM113-2 or RETS113X for LM113.

Typical Performance Characteristics

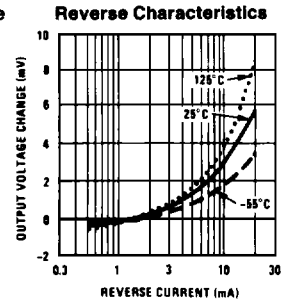
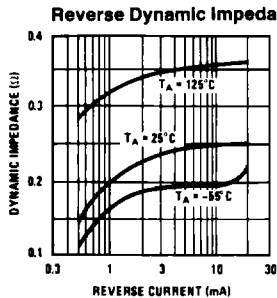
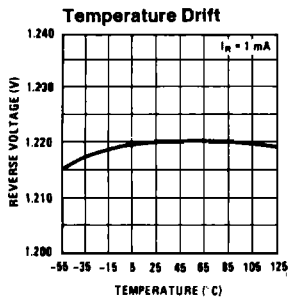

TL/H/5713-3

Typical Performance Characteristics (Continued)

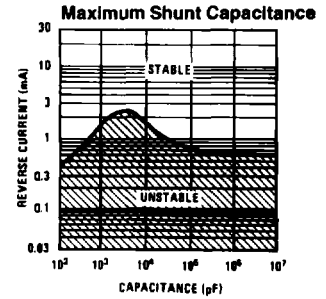
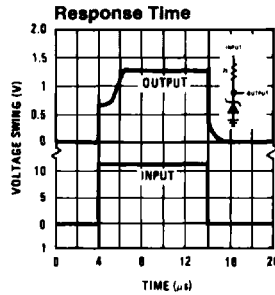
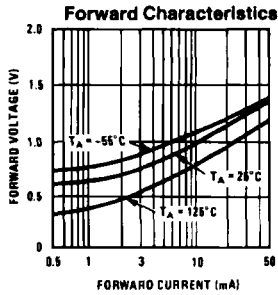
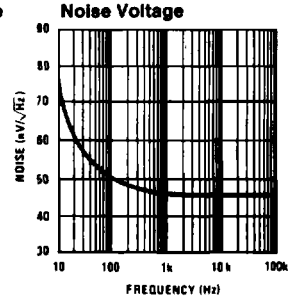
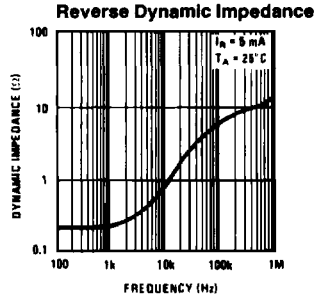
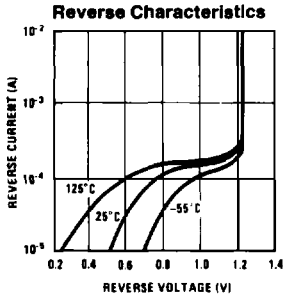

TL/H/5713-4

Typical Applications (Continued)

Amplifier Biasing for Constant Gain with Temperature

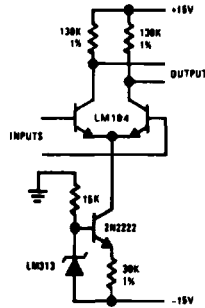

Constant Current Source

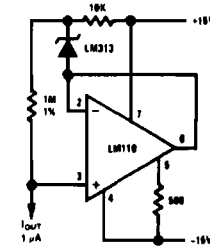

Thermometer

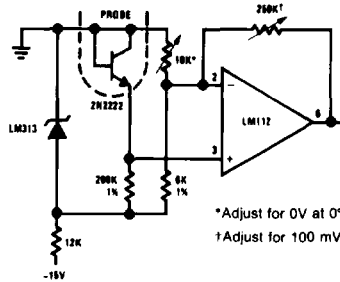

*Adjust for 0V at 0°C
†Adjust for 100 mV/°C

TL/H/5713-5