

# GD54/74LS15

## TRIPLE 3-INPUT POSITIVE AND GATES WITH OPEN-COLLECTOR OUTPUTS

### Description

This device contains three independent gates each of which performs the logic AND function.  $Y = ABC$   
The open-collector outputs require external pull-up resistors for proper logical operation.

### Function Table (each gate)

Inputs			Output
A	B	C	Y
X	X	L	L
X	L	X	L
L	X	X	L
H	H	H	H

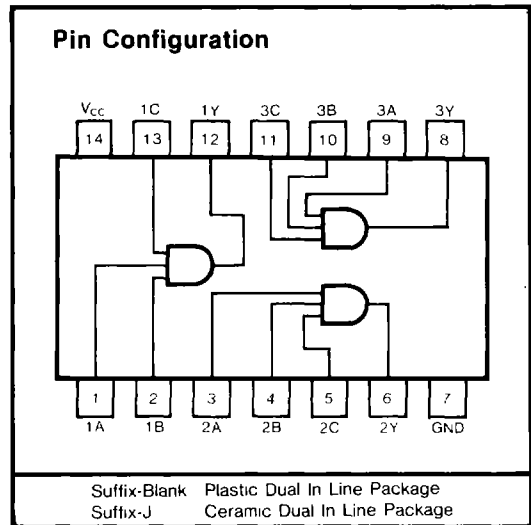

### Pull-Up Resistor Equations

$$R_{MAX} = \frac{V_{CC}(Min) - V_{OH}}{N_1(I_{OH}) + N_2(I_{IH})}$$

$$R_{MIN} = \frac{V_{CC}(Max) - V_{OL}}{I_{OL} - N_3(I_{IL})}$$

Where:  $N_1(I_{OH})$  = total maximum output high current for all outputs tied to pull-up resistor  
 $N_2(I_{IH})$  = total maximum input high current for all inputs tied to pull-up resistor  
 $N_3(I_{IL})$  = total maximum input low current for all inputs tied to pull-up resistor

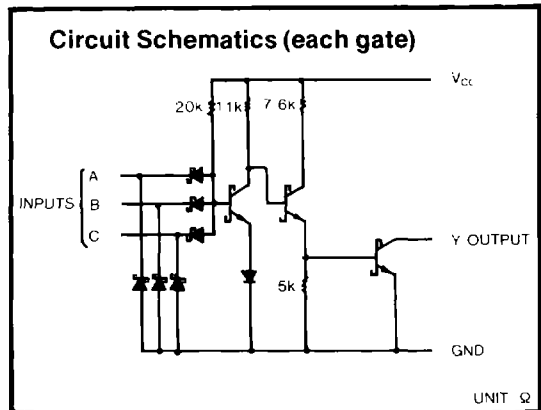

### Absolute Maximum Ratings

- Supply voltage,  $V_{CC}$  ..... 7V
- Input voltage ..... 7V
- Output voltage ..... 7V
- Operating free-air temperature range 54LS .....  $-55^{\circ}\text{C}$  to  $125^{\circ}\text{C}$   
74LS .....  $0^{\circ}\text{C}$  to  $70^{\circ}\text{C}$
- Storage temperature range .....  $-65^{\circ}\text{C}$  to  $150^{\circ}\text{C}$

**Recommended Operating Conditions**

SYMBOL	PARAMETER		MIN	NOM	MAX	UNIT
V <sub>CC</sub>	Supply voltage	54	4.5	5	5.5	V
		74	4.75	5	5.25	
V <sub>OH</sub>	High-level output voltage	54, 74			5.5	V
I <sub>OL</sub>	Low-level output current	54			4	mA
		74			8	
T <sub>A</sub>	Operating free-air temperature	54	-55		125	°C
		74	0		70	

**Electrical Characteristics** over recommended operating free-air temperature range (unless otherwise noted)

SYMBOL	PARAMETER	TEST CONDITIONS	MIN	TYP (Note 1)	MAX	UNIT
V <sub>IH</sub>	High-level input voltage		2			V
V <sub>IL</sub>	Low-level input voltage	54			0.7	V
		74			0.8	
V <sub>IK</sub>	Input clamp voltage	V <sub>CC</sub> =Min, I <sub>I</sub> =-18mA			-1.5	V
I <sub>OH</sub>	High-level output current	V <sub>CC</sub> =Min, V <sub>OH</sub> =Max, V <sub>IH</sub> =2V			100	μA
V <sub>OL</sub>	Low-level output Voltage	V <sub>CC</sub> =Min I <sub>OL</sub> =4mA	54, 74	0.25	0.4	V
		V <sub>IL</sub> =Max I <sub>OL</sub> =8mA	74	0.35	0.5	
I <sub>I</sub>	Input current at maximum input voltage	V <sub>CC</sub> =Max, V <sub>I</sub> =7V			0.1	mA
I <sub>IH</sub>	High-level input current	V <sub>CC</sub> =Max, V <sub>I</sub> =2.7V			20	μA
I <sub>IL</sub>	Low-level input current	V <sub>CC</sub> =Max, V <sub>I</sub> =0.4V			-0.4	mA
I <sub>CC</sub> H	Supply current	Total with outputs high V <sub>CC</sub> =Max		1.8	3.6	mA
I <sub>CC</sub> L		Total with outputs low V <sub>CC</sub> =Max		3.3	6.6	mA

Note 1 All typical values are at V<sub>CC</sub>=5V T<sub>A</sub>=25°C

**Switching Characteristics, V<sub>CC</sub> = 5V, T<sub>A</sub> = 25°C**

SYMBOL	PARAMETER	TEST CONDITION#	MIN	TYP	MAX	UNIT
t <sub>PLH</sub>	Propagation delay time, low-to-high-level output	C <sub>L</sub> = 15pF, R <sub>L</sub> = 2kΩ		20	35	ns
t <sub>PHL</sub>	Propagation delay time, high-to-low-level output			17	35	ns

\*For load circuit and voltage wave forms, see page 3-11