

1 Watt DO-41 Hermetically Sealed Glass Zener Voltage Regulators

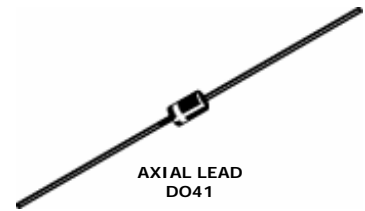

Absolute Maximum Ratings $T_A = 25^\circ\text{C}$ unless otherwise noted

Parameter	Value	Units
Storage Temperature Range	-65 to +200	$^\circ\text{C}$
Maximum Junction Operating Temperature	+200	$^\circ\text{C}$
Total Device Dissipation	1.0	Watt
Thermal Resistance Junction to Lead	53.5	$^\circ\text{C} / \text{W}$
Thermal Resistance Junction to Ambient	100	$^\circ\text{C} / \text{W}$
Lead Temperature (1/16" from case for 10 seconds)	+230	$^\circ\text{C}$

These ratings are limiting values above which the serviceability of the diode may be impaired.

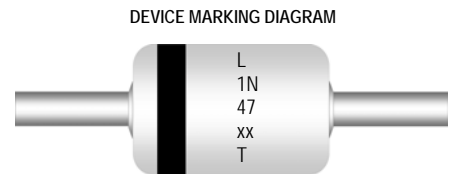

L : Logo
 Device Code : TC1N47xxT
 VZ Tolerance (T) : A = $\pm 5\%$
 C = $\pm 2\%$

Specification Features:

- Zener Voltage Range 3.3 to 56 Volts
- DO-41 Package (JEDEC)
- Through-Hole Device Type Mounting
- Hermetically Sealed Glass
- Compression Bonded Construction
- All external surfaces are corrosion resistant and leads are readily solderable
- Cathode indicated by polarity band



ELECTRICAL SYMBOL

Electrical Characteristics $T_A = 25^\circ\text{C}$ unless otherwise noted

Device Type	$V_Z @ I_{ZT}$ (Volts) Nominal	I_{ZT} (mA)	$Z_{ZT} @ I_{ZT}$ (Ω) Max	I_{ZK} (mA)	$Z_{ZK} @ I_{ZK}$ (Ω) Max	$I_R @ V_R$ (μA) Max	V_R (Volts)
TC1N4728A	3.3	76	10	1	400	100	1
TC1N4729A	3.6	69	10	1	400	100	1
TC1N4730A	3.9	64	9	1	400	50	1
TC1N4731A	4.3	58	9	1	400	10	1
TC1N4732A	4.7	53	8	1	500	10	1
TC1N4733A	5.1	49	7	1	550	10	1
TC1N4734A	5.6	45	5	1	600	10	2
TC1N4735A	6.2	41	2	1	700	10	3
TC1N4736A	6.8	37	3.5	1	700	10	4
TC1N4737A	7.5	34	4	0.5	700	10	5
TC1N4738A	8.2	31	4.5	0.5	700	10	6
TC1N4739A	9.1	28	5	0.5	700	10	7
TC1N4740A	10	25	7	0.25	700	10	7.6
TC1N4741A	11	23	8	0.25	700	5	8.4
TC1N4742A	12	21	9	0.25	700	5	9.1
TC1N4743A	13	19	10	0.25	700	5	9.9
TC1N4744A	15	17	14	0.25	700	5	11.4
TC1N4745A	16	15.5	16	0.25	700	5	12.2
TC1N4746A	18	14	20	0.25	700	5	13.7
TC1N4747A	20	12.5	22	0.25	750	5	15.2
TC1N4748A	22	11.5	23	0.25	750	5	16.7
TC1N4749A	24	10.5	25	0.25	750	5	18.2

Electrical Characteristics $T_A = 25^\circ\text{C}$ unless otherwise noted

Device Type	$V_Z @ I_{ZT}$ (Volts) Nominal	I_{ZT} (mA)	$Z_{ZT} @ I_{ZT}$ (Ω) Max	I_{ZK} (mA)	$Z_{ZK} @ I_{ZK}$ (Ω) Max	$I_R @ V_R$ (μA) Max	V_R (Volts)
TC1N4750A	27	9.5	35	0.25	750	5	20.6
TC1N4751A	30	8.5	40	0.25	1000	5	22.8
TC1N4752A	33	7.5	45	0.25	1000	5	25.1
TC1N4753A	36	7	50	0.25	1000	5	27.4
TC1N4754A	39	6.5	60	0.25	1000	5	29.7
TC1N4755A	43	6	70	0.25	1500	5	32.7
TC1N4756A	47	5.5	80	0.25	1500	5	35.8
TC1N4757A	51	5	95	0.25	1500	5	38.8
TC1N4758A	56	4.5	110	0.25	2000	5	42.6

V_F Forward Voltage = 1.2 V Maximum @ $I_F = 200$ mA for all types

Notes:

- The device numbers listed have a standard tolerance on the nominal zener voltage of $\pm 5\%$. Device tolerance of $\pm 2\%$ is indicated by a "C" instead of an "A".
- For detailed information on price, availability and delivery of nominal zener voltages between the voltages shown and tighter voltage tolerances, contact your nearest Tak Cheong's representative.
- The zener impedance is derived from the 60-cycle ac voltage, which results when an ac current having an rms value equal to 10% of the dc zener current (I_{ZT} or I_{ZK}) is superimposed to I_{ZT} or I_{ZK} .

Electrical Symbol Definition

Symbol	Parameter
V_Z	Reverse Zener Voltage @ I_{ZT}
I_{ZT}	Reverse Current
Z_{ZT}	Maximum Zener Impedance @ I_{ZT}
I_{ZK}	Reverse Current
Z_{ZK}	Maximum Zener Impedance @ I_{ZK}
I_R	Reverse Leakage Current @ V_R
V_R	Breakdown Voltage
I_F	Forward Current
V_F	Forward Voltage @ I_F

Typical Characteristics

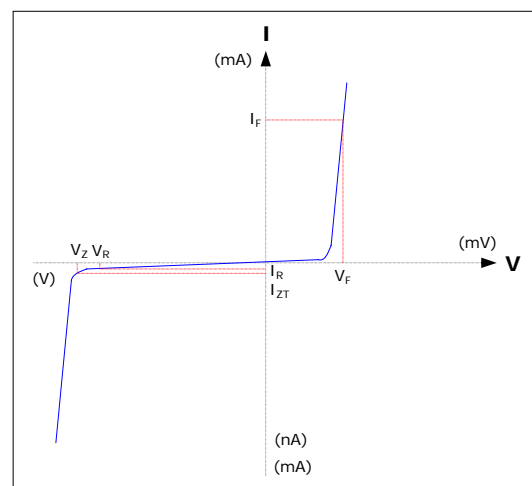

Ordering Information

Device	Package	Quantity
TC1N47xxA	Bulk	5,000
TC1N47xxA.TB	Tape and Ammo	3,000
TC1N47xxA.TR	Tape and Reel	5,000
TC1N47xxA	Others (...contact Tak Cheong sales representatives)	

Axial-Lead Tape Packaging Standards

This axial-lead component's packaging requirements use in automatic testing and assembly equipment. And this standard practices for lead-tape packaging of axial-lead components meets the requirements of EIA Standard RS-296-D "Lead-taping of Components on Axial Lead Configuration for Automatic Insertion".

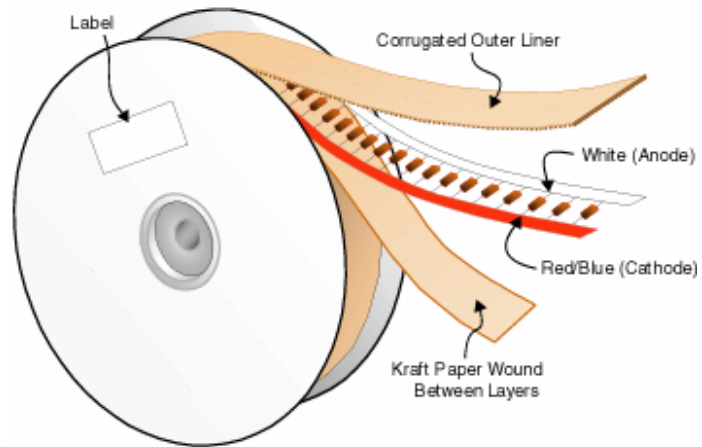
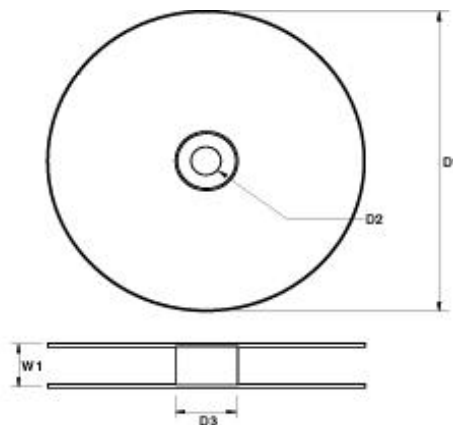
Tape & Reel Packaging Information
Tape & Reel Outline

Reel Dimensions

DIM	Millimeters
D1	356
D2	30
D3	84
W1	77.5

Quantity Per Reel

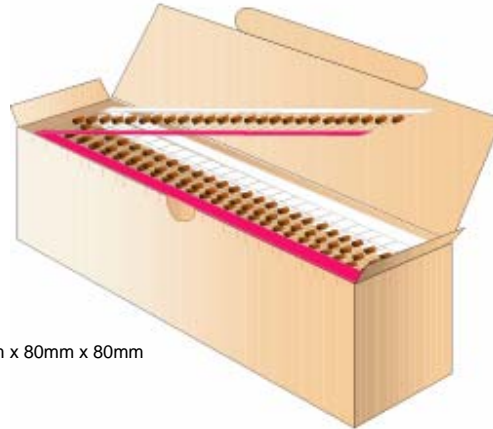
PKG Type	Quantity Per Reel
DO-41	5,000

Tape & Ammo Packaging Information
Tape & Ammo Outline

250mm x 80mm x 80mm

Quantity Per Ammo Box

PKG Type	Quantity Per Box
DO-41	3,000

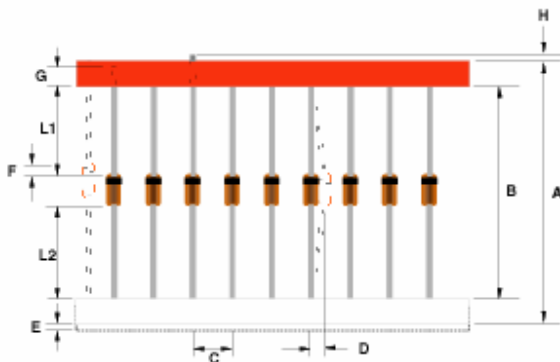
Taping Dimensions

Description	Millimeters	
	Standard Width	52
Tape Spacing (B)	52 ± 0.69	26 +0.5 / -0
Component Pitch (C)	5.08 ± 0.4	5.08 ± 0.4
Untaped Lead (L1 – L2)	± 0.69	± 0.69
Glass Offset (F)	± 0.69	± 0.69
Bent (D)	1.2 Max	1.2 Max
Tape Width (G)	6.138 ± 0.576	6.138 ± 0.576
Tape Mismatch (E)	0.55 Max	0.55 Max
Taped Lead (G)	3.2 Min	3.2 Min
Lead Beyond Tape (H)	0	0

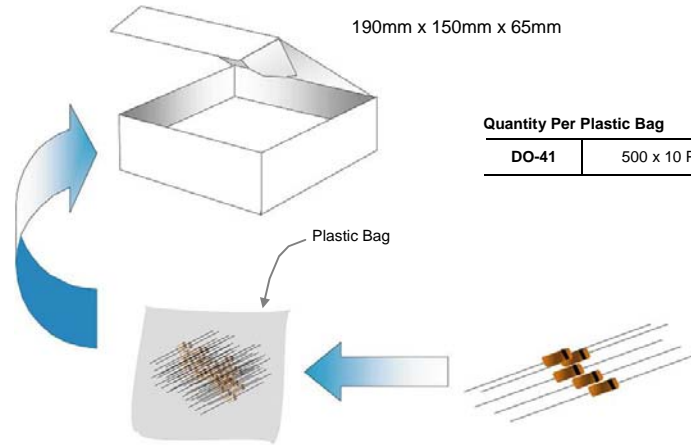
Bulk Packaging Information
Bulk Outline

Quantity Per Plastic Bag	
DO-41	500 x 10 Plastic Bag

Quantity Per Box

PKG Type	Quantity Per Box
DO-41	5,000

Package Outline

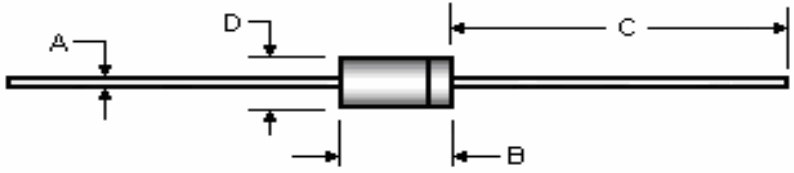
Package	Case Outline				
DO-41					
	D0-41				
	DIM	Millimeters		Inches	
		Min	Max	Min	Max
	A	0.72	0.86	0.028	0.034
	B	4.07	5.20	0.160	0.205
C	25.40	---	1.000	---	
D	2.04	2.71	0.080	0.107	

Notes:

1. All dimensions are within JEDEC standard.
2. DO41 polarity denoted by cathode band.