



# TS7800

## 3-Terminal Fixed Positive Voltage Regulators

These voltage regulators are monolithic integrated circuits designed as fixed-voltage regulators for a wide variety of applications including local, on-card regulation. These regulators employ internal current limiting, thermal shutdown, and safe-area compensation.

### FEATURES

- Output Current up to 1.5 Ampere
- No External Components Required
- Internal Thermal Overload Protection
- Internal Short-Circuit Current Limiting
- Output Transistor Safe-Area Compensation
- Output Voltage Offered in 2% Tolerance

### CIRCUIT SCHEMATIC

Representative Schematic Diagram

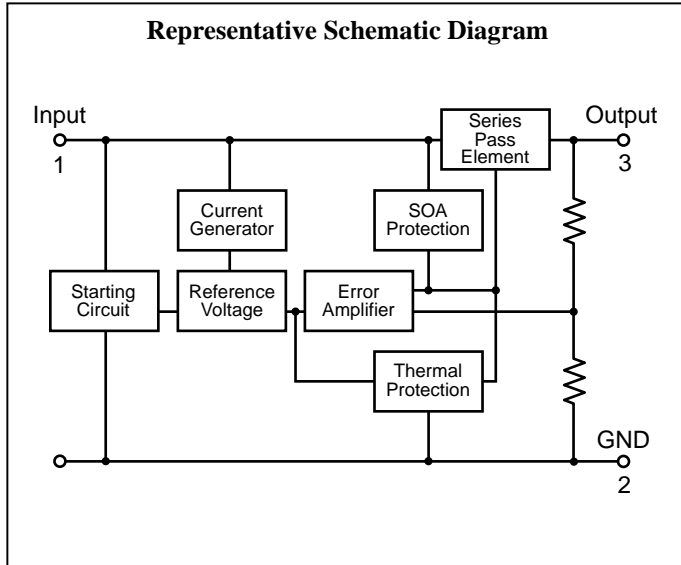

### PIN ARRANGEMENT

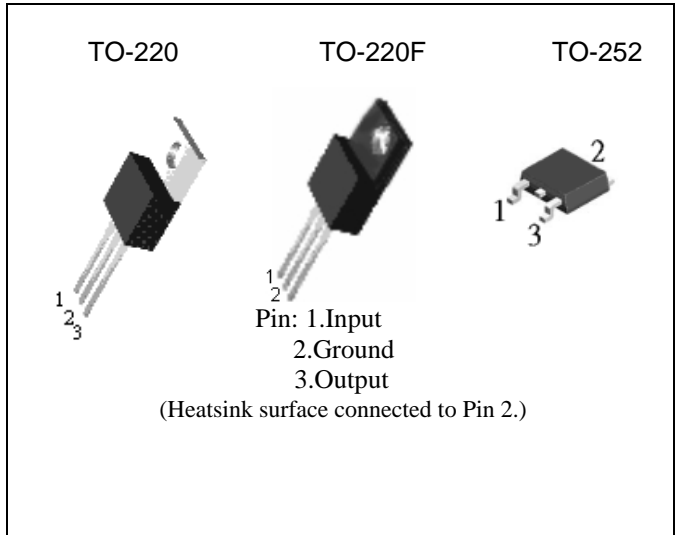

### TYPICAL CONNECTING CIRCUIT

Standard Application

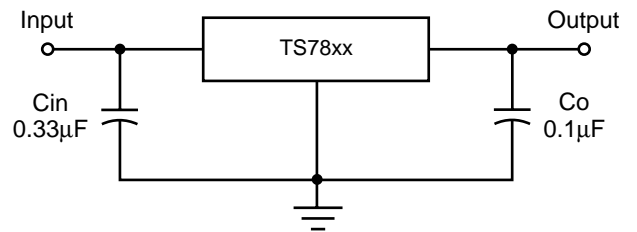

#### Notes:

A common ground is required between the input and the output voltages. The input voltage must remain typically 2.0V above the output voltage even during the low point on the input ripple voltage.

xx = these two digits of the part number indicate output voltage.

Cin is required if regulator is located an appreciable distance from power supply filter.

Co is not needed for stability, however, it does improve transient response.





# TS7800

## 3-Terminal Fixed Positive Voltage Regulators

### • ABSOLUTE MAXIMUM RATINGS (Ta=25°C)

RATING	SYMBOL	TS7800 Series	UNIT
Input Voltage	Vin *	35	V
Input Voltage	Vin **	40	V
Power Dissipation TO-220	Without heatsink	2	°C/ W
TO-220	Pt ***	15	
TO-220F	With	10	
TO-252	heatsink	10	
Operating Ambient Temperature	Topr	-20 to +85	°C
Operating Junction Temperature	Tj	0 to +125	°C
Storage Temperature	Tstg	-25 to +150	°C

Note: \* TS7805 to TS7818

\*\* TS7824

\*\*\* Follow the derating curve

### • ORDERING INFORMATION

DEVICE	OPERATING TEMPERATURE (AMBIENT)	PACKAGE
TS78xxCZ	-20°C to +85°C	TO-220
TS78xxCI		TO-220F
TS78xxCP		TO-252

### • TS7805 ELECTRICAL CHARACTERISTICS

(Vin=10V, Iout=500mA, 0°C ≤ Tj ≤ 125°C, Cin=0.33 μF, Cout=0.1 μF; unless otherwise specified.)

CHARACTERISTICS	SYMBOL	TEST CONDITIONS	MIN.	TYP.	MAX.	UNIT	
Output Voltage	Vout	Tj=25°C	4.90	5	5.10	V	
		7V ≤ Vin ≤ 20V, 5mA ≤ Iout ≤ 1.5A, PD ≤ 15W	4.85	-	5.15	V	
Line Regulation	REGline	Tj=25°C	7.5V ≤ Vin ≤ 25V	--	3	100	mV
			8V ≤ Vin ≤ 12V	--	1	50	mV
Load Regulation	REGload	Tj=25°C	5mA ≤ Iout ≤ 1.5A	--	15	100	mV
			250mA ≤ Iout ≤ 750mA	--	5	50	mV
Quiescent Current	Iq	Iout=0, Tj=25°C	--	4.2	8	mA	
Quiescent Current Change	Δ Iq	7V ≤ Vin ≤ 25V	--	--	1.3	mA	
		5mA ≤ Iout ≤ 1.5A	--	--	0.5	mA	
Output Noise Voltage	Vn	10Hz ≤ f ≤ 100KHz, Tj=25°C	--	40	--	μV	
Ripple Rejection Ratio	RR	f=120Hz, 8V ≤ Vin ≤ 18V	62	78	--	dB	
Voltage Drop	Vdrop	Iout=1.0A, Tj=25°C	--	2	--	V	
Output Resistance	Rout	f=1KHz	--	17	--	mΩ	
Output Short Circuit Current	Ios	Tj=25°C	--	750	--	mA	
Peak Output Current	Io peak	Tj=25°C	--	2.2	--	A	
Temperature Coefficient of Output Voltage	Δ Vout/Δ Tj	Iout=5mA, 0°C ≤ Tj ≤ 125°C	--	-0.6	--	mV/°C	

Pulse testing techniques are used to maintain the junction temperature as close to the ambient temperature as possible, and thermal effects must be taken into account separately.

This specification applies only for DC power dissipation permitted by absolute maximum ratings.



# TS7800

## 3-Terminal Fixed Positive Voltage Regulators

### • TS7806 ELECTRICAL CHARACTERISTICS

( $V_{in}=11V$ ,  $I_{out}=500mA$ ,  $0^{\circ}C \leq T_j \leq 125^{\circ}C$ ,  $C_{in}=0.33 \mu F$ ,  $C_{out}=0.1 \mu F$ ; unless otherwise specified.)

CHARACTERISTICS	SYMBOL	TEST CONDITIONS	MIN.	TYP.	MAX.	UNIT	
Output Voltage	Vout	Tj=25°C	5.88	6	6.12	V	
		8V ≤ Vin ≤ 21V, 5mA ≤ Iout ≤ 1.5A, PD ≤ 15W	5.82	--	6.18	V	
Line Regulation	REGline	Tj=25°C	8V ≤ Vin ≤ 25V	--	5	120	mV
			9V ≤ Vin ≤ 13V	--	1.5	60	mV
Load Regulation	REGload	Tj=25°C	5mA ≤ Iout ≤ 1.5A	--	14	120	mV
			250mA ≤ Iout ≤ 750mA	--	4	60	mV
Quiescent Current	Iq	Iout=0, Tj=25°C	--	4.3	8	mA	
Quiescent Current Change	ΔIq	8V ≤ Vin ≤ 25V	--	--	1.3	mA	
		5mA ≤ Iout ≤ 1.5A	--	--	0.5	mA	
Output Noise Voltage	Vn	10Hz ≤ f ≤ 100KHz, Tj=25°C	--	45	--	μV	
Ripple Rejection Ratio	RR	f=120Hz, 9V ≤ Vin ≤ 19V	59	75	--	dB	
Voltage Drop	Vdrop	Iout=1.0A, Tj=25°C	--	2	--	V	
Output Resistance	Rout	f=1KHz	--	19	--	mΩ	
Output Short Circuit Current	Ios	Tj=25°C	--	550	--	mA	
Peak Output Current	I <sub>o peak</sub>	Tj=25°C	--	2.2	--	A	
Temperature Coefficient of Output Voltage	ΔVout/ΔTj	Iout=5mA, 0°C ≤ Tj ≤ 125°C	--	-0.7	--	mV/°C	

### • TS7808 ELECTRICAL CHARACTERISTICS

( $V_{in}=14V$ ,  $I_{out}=500mA$ ,  $0^{\circ}C \leq T_j \leq 125^{\circ}C$ ,  $C_{in}=0.33 \mu F$ ,  $C_{out}=0.1 \mu F$ ; unless otherwise specified.)

CHARACTERISTICS	SYMBOL	TEST CONDITIONS	MIN.	TYP.	MAX.	UNIT	
Output Voltage	Vout	Tj=25°C	7.84	8	8.16	V	
		10.5V ≤ Vin ≤ 23V, 5mA ≤ Iout ≤ 1.5A, PD ≤ 15W	7.76	--	8.24	V	
Line Regulation	REGline	Tj=25°C	10.5V ≤ Vin ≤ 25V	--	6	160	mV
			11V ≤ Vin ≤ 17V	--	2	80	mV
Load Regulation	REGload	Tj=25°C	10mA ≤ Iout ≤ 1.5A	--	12	160	mV
			250mA ≤ Iout ≤ 750mA	--	4	80	mV
Quiescent Current	Iq	Iout=0, Tj=25°C	--	4.3	8	mA	
Quiescent Current Change	ΔIq	10.5V ≤ Vin ≤ 25V	--	--	1	mA	
		5mA ≤ Iout ≤ 1.5A	--	--	0.5	mA	
Output Noise Voltage	Vn	10Hz ≤ f ≤ 100KHz, Tj=25°C	--	52	--	μV	
Ripple Rejection Ratio	RR	f=120Hz, 11V ≤ Vin ≤ 21V	56	72	--	dB	
Voltage Drop	Vdrop	Iout=1.0A, Tj=25°C	--	2	--	V	
Output Resistance	Rout	f=1KHz	--	16	--	mΩ	
Output Short Circuit Current	Ios	Tj=25°C	--	450	--	mA	
Peak Output Current	I <sub>o peak</sub>	Tj=25°C	--	2.2	--	A	
Temperature Coefficient of Output Voltage	ΔVout/ΔTj	Iout=5mA, 0°C ≤ Tj ≤ 125°C	--	-0.8	--	mV/°C	

Pulse testing techniques are used to maintain the junction temperature as close to the ambient temperature as possible, and thermal effects must be taken into account separately.

This specification applies only for DC power dissipation permitted by absolute maximum ratings.



# TS7800

## 3-Terminal Fixed Positive Voltage Regulators

### • TS7809 ELECTRICAL CHARACTERISTICS

( $V_{in}=15V$ ,  $I_{out}=500mA$ ,  $0^{\circ}C \leq T_j \leq 125^{\circ}C$ ,  $C_{in}=0.33 \mu F$ ,  $C_{out}=0.1 \mu F$ ; unless otherwise specified.)

CHARACTERISTICS	SYMBOL	TEST CONDITIONS	MIN.	TYP.	MAX.	UNIT	
Output Voltage	Vout	$T_j=25^{\circ}C$	8.82	9	9.18	V	
		$11.5V \leq V_{in} \leq 24V$ , $5mA \leq I_{out} \leq 1.5A$ , $PD \leq 15W$	8.73	--	9.27	V	
Line Regulation	REGline	$T_j=25^{\circ}C$	$11.5V \leq V_{in} \leq 26V$	--	6	180	mV
			$11.5V \leq V_{in} \leq 17V$	--	2	90	mV
Load Regulation	REGload	$T_j=25^{\circ}C$	$5mA \leq I_{out} \leq 1.5A$	--	12	180	mV
			$250mA \leq I_{out} \leq 750mA$	--	4	90	mV
Quiescent Current	Iq	$I_{out}=0$ , $T_j=25^{\circ}C$	--	4.3	8	mA	
Quiescent Current Change	$\Delta Iq$	$11.5V \leq V_{in} \leq 26V$	--	--	1	mA	
		$5mA \leq I_{out} \leq 1.5A$	--	--	0.5	mA	
Output Noise Voltage	Vn	$10Hz \leq f \leq 100KHz$ , $T_j=25^{\circ}C$	--	52	--	$\mu V$	
Ripple Rejection Ratio	RR	$f=120Hz$ , $11.5V \leq V_{in} \leq 21.5V$	55	72	--	dB	
Voltage Drop	Vdrop	$I_{out}=1.0A$ , $T_j=25^{\circ}C$	--	2	--	V	
Output Resistance	Rout	$f=1KHz$	--	16	--	$m\Omega$	
Output Short Circuit Current	Ios	$T_j=25^{\circ}C$	--	450	--	mA	
Peak Output Current	I <sub>o peak</sub>	$T_j=25^{\circ}C$	--	2.2	--	A	
Temperature Coefficient of Output Voltage	$\Delta V_{out} / \Delta T_j$	$I_{out}=5mA$ , $0^{\circ}C \leq T_j \leq 125^{\circ}C$	--	-1	--	mV/ $^{\circ}C$	

### • TS7810 ELECTRICAL CHARACTERISTICS

( $V_{in}=16V$ ,  $I_{out}=500mA$ ,  $0^{\circ}C \leq T_j \leq 125^{\circ}C$ ,  $C_{in}=0.33 \mu F$ ,  $C_{out}=0.1 \mu F$ ; unless otherwise specified.)

CHARACTERISTICS	SYMBOL	TEST CONDITIONS	MIN.	TYP.	MAX.	UNIT	
Output Voltage	Vout	$T_j=25^{\circ}C$	9.8	10	10.2	V	
		$12.5V \leq V_{in} \leq 25V$ , $5mA \leq I_{out} \leq 1.5A$ , $PD \leq 15W$	9.7	-	10.3	V	
Line Regulation	REGline	$T_j=25^{\circ}C$	$12.5V \leq V_{in} \leq 28V$	--	7	200	mV
			$13V \leq V_{in} \leq 17V$	--	2	100	mV
Load Regulation	REGload	$T_j=25^{\circ}C$	$10mA \leq I_{out} \leq 1.5A$	--	12	200	mV
			$250mA \leq I_{out} \leq 750mA$	--	4	100	mV
Quiescent Current	Iq	$I_{out}=0$ , $T_j=25^{\circ}C$	--	4.3	8	mA	
Quiescent Current Change	$\Delta Iq$	$12.5V \leq V_{in} \leq 28V$	--	--	1	mA	
		$5mA \leq I_{out} \leq 1.5A$	--	--	0.5	mA	
Output Noise Voltage	Vn	$10Hz \leq f \leq 100KHz$ , $T_j=25^{\circ}C$	--	70	--	$\mu V$	
Ripple Rejection Ratio	RR	$f=120Hz$ , $13V \leq V_{in} \leq 23V$	55	71	--	dB	
Voltage Drop	Vdrop	$I_{out}=1.0A$ , $T_j=25^{\circ}C$	--	2	--	V	
Output Resistance	Rout	$f=1KHz$	--	18	--	$m\Omega$	
Output Short Circuit Current	Ios	$T_j=25^{\circ}C$	--	400	--	mA	
Peak Output Current	I <sub>o peak</sub>	$T_j=25^{\circ}C$	--	2.2	--	A	
Temperature Coefficient of Output Voltage	$\Delta V_{out} / \Delta T_j$	$I_{out}=5mA$ , $0^{\circ}C \leq T_j \leq 125^{\circ}C$	--	-1	--	mV/ $^{\circ}C$	

Pulse testing techniques are used to maintain the junction temperature as close to the ambient temperature as possible, and thermal effects must be taken into account separately.

This specification applies only for DC power dissipation permitted by absolute maximum ratings.



# TS7800

## 3-Terminal Fixed Positive Voltage Regulators

### • TS7812 ELECTRICAL CHARACTERISTICS

$V_{in}=19V$ ,  $I_{out}=500mA$ ,  $0^{\circ}C \leq T_j \leq 125^{\circ}C$ ,  $C_{in}=0.33 \mu F$ ,  $C_{out}=0.1 \mu F$ ; unless otherwise specified.)

CHARACTERISTICS	SYMBOL	TEST CONDITIONS	MIN.	TYP.	MAX.	UNIT	
Output Voltage	Vout	Tj=25°C	11.76	12.0	12.24	V	
		14.5V ≤ Vin ≤ 27V, 5mA ≤ Iout ≤ 1.5A, PD ≤ 15W	11.64	--	12.36	V	
Line Regulation	REGline	Tj=25°C	14V ≤ Vin ≤ 30V	--	10	240	mV
			15V ≤ Vin ≤ 19V	--	3	120	mV
Load Regulation	REGload	Tj=25°C	10mA ≤ Iout ≤ 1.5A	--	12	240	mV
			250mA ≤ Iout ≤ 750mA	--	4	120	mV
Quiescent Current	Iq	Tj=25°C, Iout=0	--	4.3	8	mA	
Quiescent Current Change	ΔIq	14.5V ≤ Vin ≤ 30V	--	--	1	mA	
		5mA ≤ Iout ≤ 1.5A	--	--	0.5	mA	
Output Noise Voltage	Vn	10Hz ≤ f ≤ 100KHz, Tj=25°C	--	75	--	μV	
Ripple Rejection Ratio	RR	f=120Hz, 15V ≤ Vin ≤ 25V	55	71	--	dB	
Voltage Drop	Vdrop	Iout=1.0A, Tj=25°C	--	20	--	V	
Output Resistance	Rout	f=1KHz	--	18	--	mΩ	
Output Short Circuit Current	Ios	Tj=25°C	--	350	--	mA	
Peak Output Current	I <sub>o peak</sub>	Tj=25°C	--	2.2	--	A	
Temperature Coefficient of Output Voltage	ΔVout/ΔTj	Iout=5mA, 0°C ≤ Tj ≤ 125°C	--	-1	--	mV/°C	

### • TS7815 ELECTRICAL CHARACTERISTICS

$V_{in}=23V$ ,  $I_{out}=500mA$ ,  $0^{\circ}C \leq T_j \leq 125^{\circ}C$ ,  $C_{in}=0.33 \mu F$ ,  $C_{out}=0.1 \mu F$ ; unless otherwise specified.)

CHARACTERISTICS	SYMBOL	TEST CONDITIONS	MIN.	TYP.	MAX.	UNIT	
Output Voltage	Vout	Tj=25°C	14.7	15	15.3	V	
		17.5V ≤ Vin ≤ 30V, 5mA ≤ Iout ≤ 1.5A, PD ≤ 15W	14.55	--	15.45	V	
Line Regulation	REGline	Tj=25°C	17.5V ≤ Vin ≤ 30V	--	12	300	mV
			18V ≤ Vin ≤ 22V	--	3	150	mV
Load Regulation	REGload	Tj=25°C	10mA ≤ Iout ≤ 1.5A	--	12	300	mV
			250mA ≤ Iout ≤ 750mA	--	4	150	mV
Quiescent Current	Iq	Tj=25°C, Iout=0	--	4.3	8	mA	
Quiescent Current Change	ΔIq	17.5V ≤ Vin ≤ 30V	--	--	1	mA	
		5mA ≤ Iout ≤ 1.5A	--	--	0.5	mA	
Output Noise Voltage	Vn	10Hz ≤ f ≤ 100KHz, Tj=25°C	--	90	--	μV	
Ripple Rejection Ratio	RR	f=120Hz, 18V ≤ Vin ≤ 28V	54	70	--	dB	
Voltage Drop	Vdrop	Iout=1.0A, Tj=25°C	--	2	--	V	
Output Resistance	Rout	f=1KHz	--	19	--	mΩ	
Output Short Circuit Current	Ios	Tj=25°C	--	230	--	mA	
Peak Output Current	I <sub>o peak</sub>	Tj=25°C	--	2.1	--	A	
Temperature Coefficient of Output Voltage	ΔVout/ΔTj	Iout=5mA, 0°C ≤ Tj ≤ 125°C	--	-1	--	mV/°C	

Pulse testing techniques are used to maintain the junction temperature as close to the ambient temperature as possible, and thermal effects must be taken into account separately.

This specification applies only for DC power dissipation permitted by absolute maximum ratings.



# TS7800

## 3-Terminal Fixed Positive Voltage Regulators

### • TS7818 ELECTRICAL CHARACTERISTICS

( $V_{in}=27V$ ,  $I_{out}=500mA$ ,  $0^{\circ}C \leq T_j \leq 125^{\circ}C$ ,  $C_{in}=0.33 \mu F$ ,  $C_{out}=0.1 \mu F$ ; unless otherwise specified.)

CHARACTERISTICS	SYMBOL	TEST CONDITIONS	MIN.	TYP.	MAX.	UNIT	
Output Voltage	Vout	$T_j=25^{\circ}C$	17.64	18	18.36	V	
		$21V \leq V_{in} \leq 33V$ , $5mA \leq I_{out} \leq 1.5A$ , $PD \leq 15W$	17.46	--	18.54	V	
Line Regulation	REGline	$T_j=25^{\circ}C$	$21V \leq V_{in} \leq 33V$	--	15	360	mV
			$22V \leq V_{in} \leq 26V$	--	5	180	mV
Load Regulation	REGload	$T_j=25^{\circ}C$	$10mA \leq I_{out} \leq 1.5A$	--	12	360	mV
			$250mA \leq I_{out} \leq 750mA$	--	4	180	mV
Quiescent Current	Iq	$T_j=25^{\circ}C$ , $I_{out}=0$	--	4.5	8	mA	
Quiescent Current Change	$\Delta Iq$	$21V \leq V_{in} \leq 33V$	--	--	1	mA	
		$5mA \leq I_{out} \leq 1.5A$	--	--	0.5	mA	
Output Noise Voltage	Vn	$10Hz \leq f \leq 100KHz$ , $T_j=25^{\circ}C$	--	110	--	$\mu V$	
Ripple Rejection Ratio	RR	$f=120Hz$ , $21V \leq V_{in} \leq 31V$	54	70	--	dB	
Voltage Drop	Vdrop	$I_{out}=1.0A$ , $T_j=25^{\circ}C$	--	2	--	V	
Output Resistance	Rout	$f=1KHz$	--	22	--	m $\Omega$	
Output Short Circuit Current	Ios	$T_j=25^{\circ}C$	--	200	--	mA	
Peak Output Current	I <sub>o peak</sub>	$T_j=25^{\circ}C$	--	2.1	--	A	
Temperature Coefficient of Output Voltage	$\Delta V_{out} / \Delta T_j$	$I_{out}=5mA$ , $0^{\circ}C \leq T_j \leq 125^{\circ}C$	--	-1	--	mV/ $^{\circ}C$	

### • TS7824 ELECTRICAL CHARACTERISTICS

( $V_{in}=33V$ ,  $I_{out}=500mA$ ,  $0^{\circ}C \leq T_j \leq 125^{\circ}C$ ,  $C_{in}=0.33 \mu F$ ,  $C_{out}=0.1 \mu F$ ; unless otherwise specified.)

CHARACTERISTICS	SYMBOL	TEST CONDITIONS	MIN.	TYP.	MAX.	UNIT	
Output Voltage	Vout	$T_j=25^{\circ}C$	23.52	24	24.48	V	
		$26V \leq V_{in} \leq 38V$ , $5mA \leq I_{out} \leq 1.5A$ , $PD \leq 15W$	23.28	--	24.72	V	
Line Regulation	REGline	$T_j=25^{\circ}C$	$26V \leq V_{in} \leq 38V$	--	18	480	mV
			$27V \leq V_{in} \leq 32V$	--	6	240	mV
Load Regulation	REGload	$T_j=25^{\circ}C$	$10mA \leq I_{out} \leq 1.5A$	--	12	480	mV
			$250mA \leq I_{out} \leq 750mA$	--	4	240	mV
Quiescent Current	Iq	$I_{out}=0$ , $T_j=25^{\circ}C$	--	4.6	8	mA	
Quiescent Current Change	$\Delta Iq$	$26V \leq V_{in} \leq 38V$	--	--	1	mA	
		$5mA \leq I_{out} \leq 1.5A$	--	--	0.5	mA	
Output Noise Voltage	Vn	$10Hz \leq f \leq 100KHz$ , $T_j=25^{\circ}C$	--	170	--	$\mu V$	
Ripple Rejection Ratio	RR	$f=120Hz$ , $26V \leq V_{in} \leq 36V$	54	70	--	dB	
Voltage Drop	Vdrop	$I_{out}=1.0A$ , $T_j=25^{\circ}C$	--	2	--	V	
Output Resistance	Rout	$f=1KHz$	--	28	--	m $\Omega$	
Output Short Circuit Current	Ios	$T_j=25^{\circ}C$	--	150	--	mA	
Peak Output Current	I <sub>o peak</sub>	$T_j=25^{\circ}C$	--	2.1	--	A	
Temperature Coefficient of Output Voltage	$\Delta V_{out} / \Delta T_j$	$I_{out}=5mA$ , $0^{\circ}C \leq T_j \leq 125^{\circ}C$	--	-1.5	--	mV/ $^{\circ}C$	

Pulse testing techniques are used to maintain the junction temperature as close to the ambient temperature as possible, and thermal effects must be taken into account separately.

This specification applies only for DC power dissipation permitted by absolute maximum ratings.



# TS7800

## 3-Terminal Fixed Positive Voltage Regulators

FIGURE 1 - WORST CASE POWER DISSIPATION versus AMBIENT TEMPERATURE

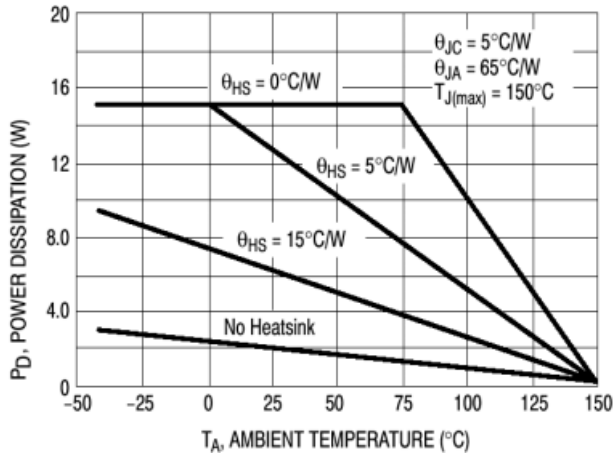

FIGURE 2 - PEAK OUTPUT CURRENT AS A FUNCTION OF INPUT-OUTPUT DIFFERENTIAL VOLTAGE

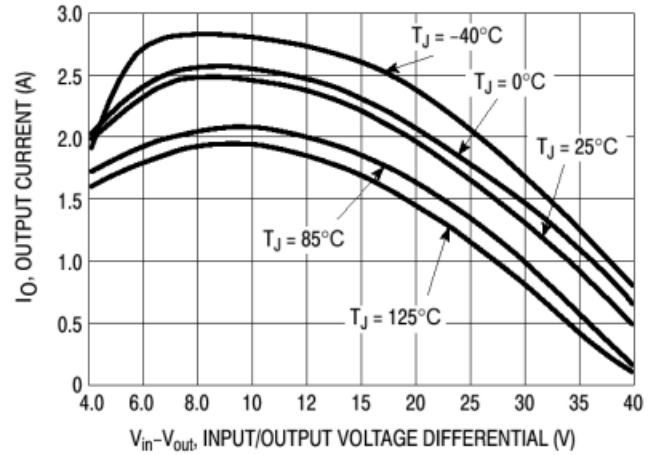

FIGURE 3 - QUIESCENT CURRENT AS A FUNCTION OF TEMPERATURE

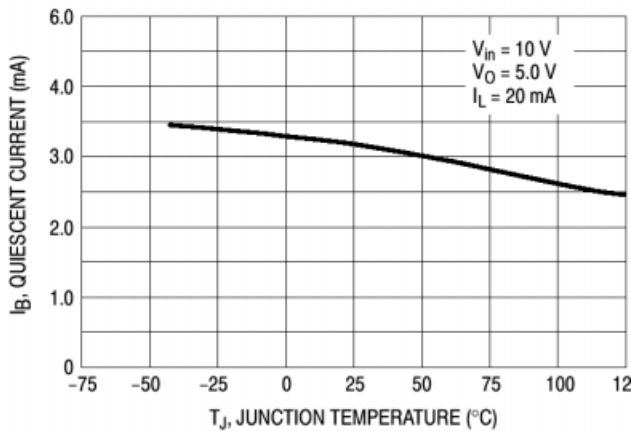

FIGURE 4 - INPUT OUTPUT DIFFERENTIAL AS A FUNCTION OF JUNCTION TEMPERATURE

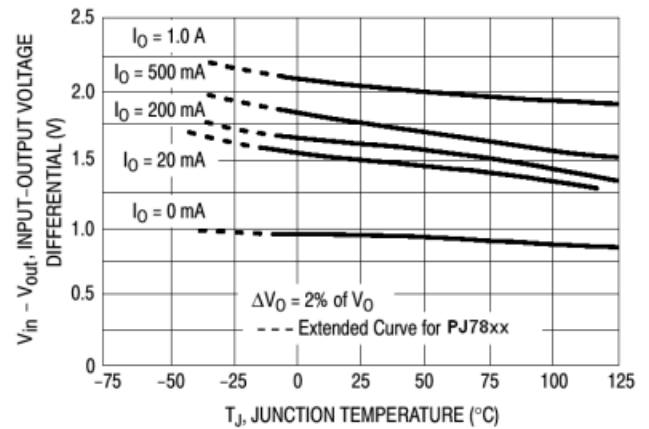

FIGURE 5 - OUTPUT VOLTAGE AS A FUNCTION OF JUNCTION TEMPERATURE

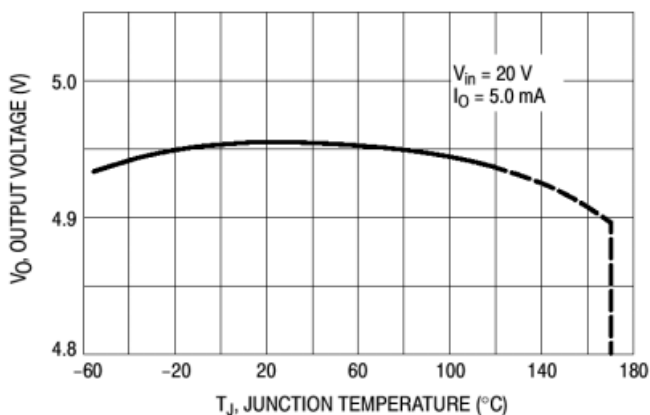
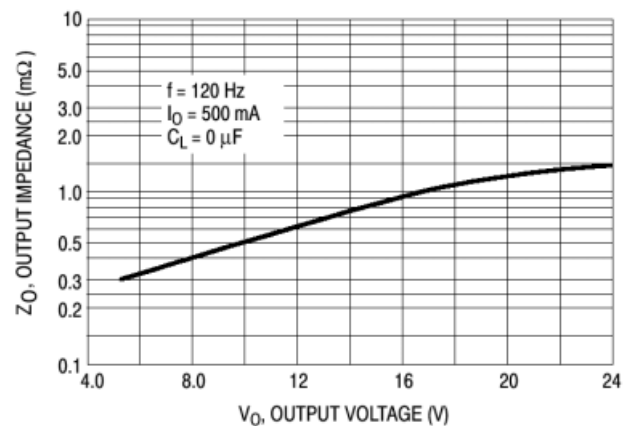

FIGURE 6 - OUTPUT IMPEDANCE AS A FUNCTION OF OUTPUT VOLTAGE





# TS7800

## 3-Terminal Fixed Positive Voltage Regulators

FIGURE 7 - RIPPLE REJECTION AS A FUNCTION OF OUTPUT VOLTAGE

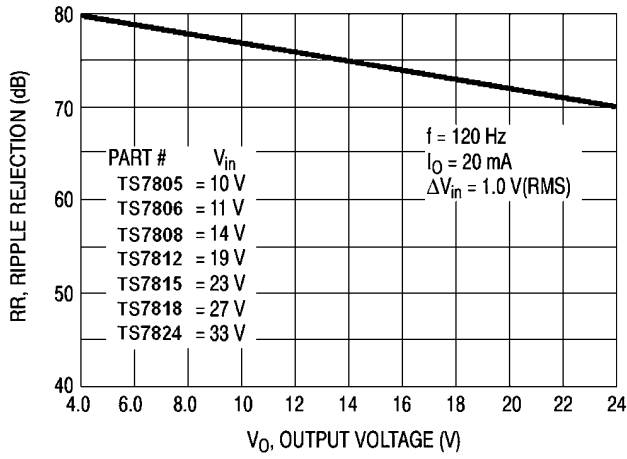
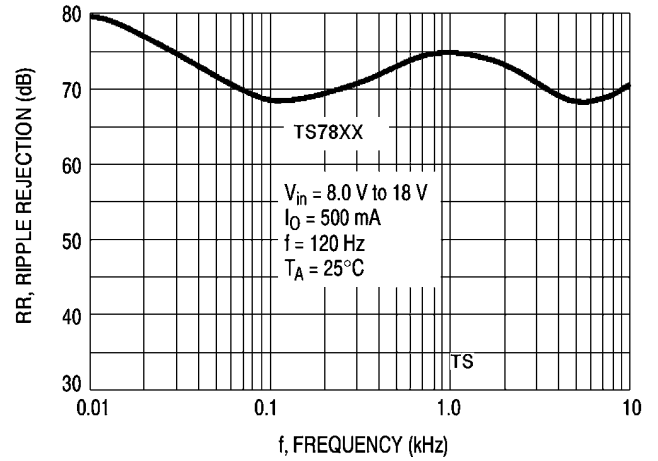

FIGURE 8 - RIPPLE REJECTION AS A FUNCTION OF FREQUENCY





# TS7800

## 3-Terminal Fixed Positive Voltage Regulators

### TO-220 Mechanical drawing

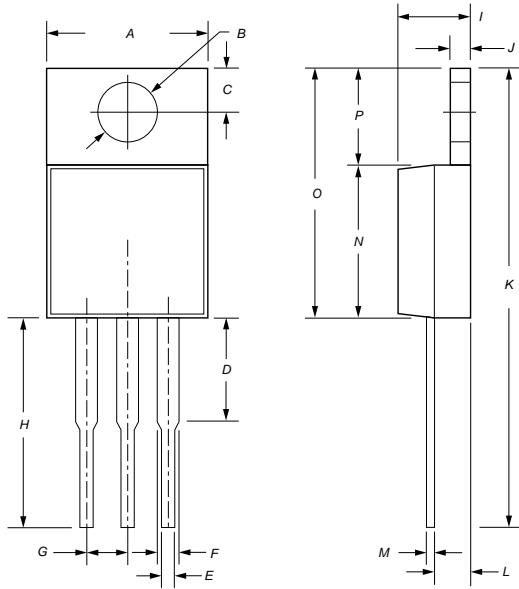

TO-220 DIMENSION				
DIM	MILLIMETERS		INCHES	
	MIN	MAX	MIN	MAX
A	10.00	10.50	0.394	0.413
B	3.24	4.44	0.128	0.175
C	2.44	2.94	0.096	0.116
D	3.565	4.315	0.140	0.170
E	0.68	0.92	0.027	0.036
F	1.115	1.485	0.044	0.058
G	2.345	2.715	0.092	0.107
H	13.49	14.31	0.531	0.563
I	4.475	5.225	0.176	0.206
J	1.15	1.39	0.045	0.055
K	27.78	29.62	1.094	1.166
L	2.175	2.925	0.086	0.115
M	0.297	0.477	0.012	0.019
N	8.28	8.80	0.326	0.346
O	14.29	15.31	0.563	0.603
P	6.01	6.51	0.237	0.256

### TO-220F Mechanical drawing

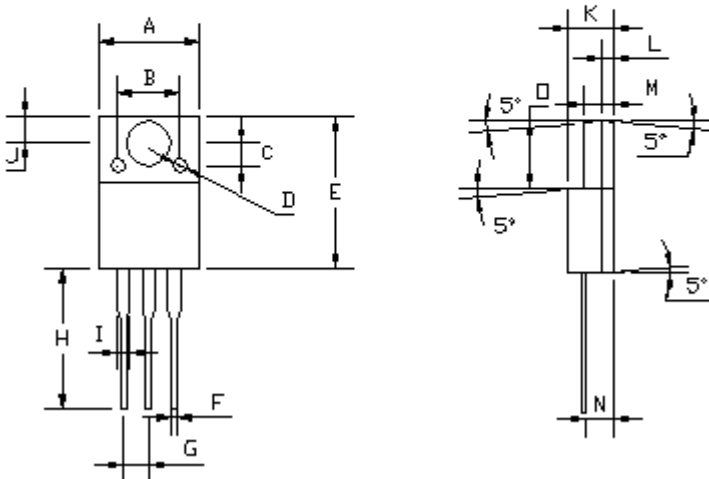

TO-220F DIMENSION				
DIM	MILLIMETERS		INCHES	
	MIN	MAX	MIN	MAX
A	9.9	10.1	0.390	0.398
B	6.2	6.2	0.244	0.244
C	2.2	2.2	0.087	0.087
D	1.4	1.4	0.055	0.055
E	15.0	15.2	0.591	0.598
F	0.48	0.72	0.019	0.028
G	2.355	2.725	0.093	0.107
H	13.49	14.31	0.531	0.563
I	1.115	1.485	0.044	0.058
J	2.6	2.8	0.102	0.110
K	4.4	4.6	0.173	0.181
L	1.115	1.15	0.045	0.045
M	2.95	3.15	0.116	0.124
N	2.6	2.8	0.102	0.110
O	6.55	6.65	0.258	0.262

### TO-252 Mechanical drawing

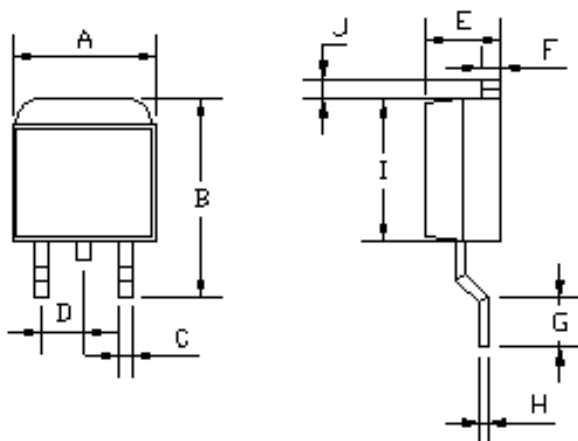

DIM	MILLIMETERS		INCHES	
	MIN	MAX	MIN	MAX
A	6.45	6.55	0.254	0.258
B	9.74	10.7	0.383	0.421
C	0.55	0.65	0.022	0.026
D	2.25	2.35	0.089	0.093
E	1.80	2.80	0.071	0.110
F	0.45	0.56	0.018	0.022
G	0.95	1.45	0.037	0.057
H	0.40	0.60	0.016	0.024
I	5.32	5.57	0.209	0.219
J	1.52	2.03	0.06	0.080