

REVISIONS

LTR	DESCRIPTION	DATE (YR-MO-DA)	APPROVED
A	Add case outline 2 to device type 01. Update document. Editorial changes throughout.	89-09-13	M. A. FRYE
B	Delete vendor CAGE 64155. Change boilerplate to add one-part numbers. Add delta test limit table. Make changes to I _{IO} , I _{IB} , and A _{VO} tests as specified under table I.	96-12-31	R. MONNIN
C	Add radiation hardened assurance requirements. - ro	99-02-16	R. MONNIN
D	Replaced reference to MIL-STD-973 with reference to MIL-PRF-38535. Drawing updated to reflect current requirements. - gt	04-08-06	R. MONNIN
E	Add a new footnote under paragraph 1.5 and Table I. - ro	05-08-10	R. MONNIN

THE ORIGINAL FIRST SHEET OF THIS DRAWING HAS BEEN REPLACED.

REV																				
SHEET																				
REV																				
SHEET																				
REV STATUS	REV	E	E	E	E	E	E	E	E	E	E	E	E	E	E					
OF SHEETS	SHEET	1	2	3	4	5	6	7	8	9	10	11	12							

PMIC N/A	PREPARED BY JOSEPH A. KERBY	<p align="center">DEFENSE SUPPLY CENTER COLUMBUS COLUMBUS, OHIO 43218-3990 http://www.dsc.dla.mil</p>																	
<p align="center">STANDARD MICROCIRCUIT DRAWING</p> <p>THIS DRAWING IS AVAILABLE FOR USE BY ALL DEPARTMENTS AND AGENCIES OF THE DEPARTMENT OF DEFENSE</p> <p align="center">AMSC N/A</p>	CHECKED BY RAYMOND MONNIN																		
	APPROVED BY MICHAEL A. FRYE	<p align="center">MICROCIRCUIT, LINEAR, DUAL PRECISION JFET-INPUT OPERATIONAL AMPLIFIERS, MONOLITHIC SILICON</p>																	
	DRAWING APPROVAL DATE 88-10-07																		
	REVISION LEVEL E	SIZE A	CAGE CODE 67268	5962-88538															
		SHEET		1 OF 12															

1. SCOPE

1.1 Scope. This drawing documents two product assurance class levels consisting of high reliability (device classes Q and M) and space application (device class V). A choice of case outlines and lead finishes are available and are reflected in the Part or Identifying Number (PIN). When available, a choice of Radiation Hardness Assurance (RHA) levels is reflected in the PIN.

1.2 PIN. The PIN is as shown in the following examples.

For device classes M and Q:

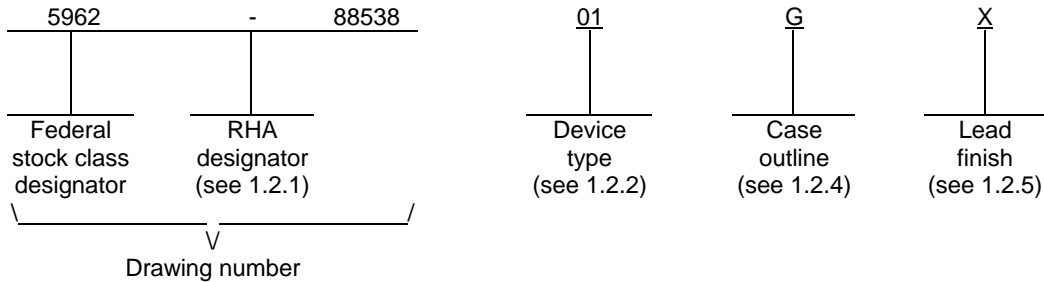

For device class V:

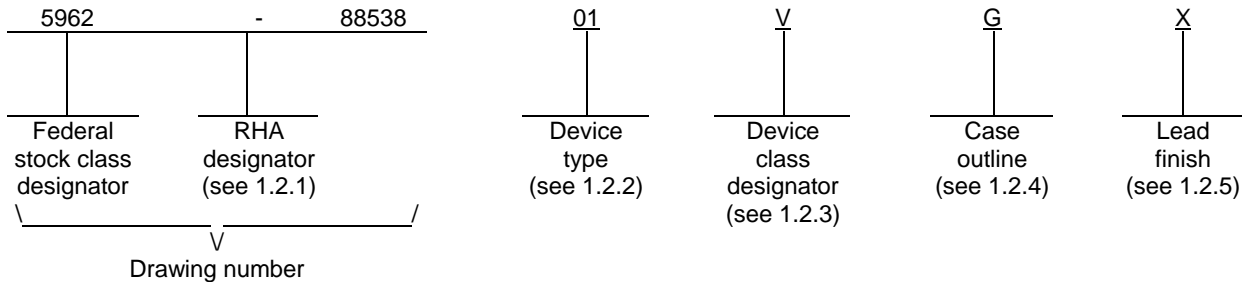

1.2.1 RHA designator. Device classes Q and V RHA marked devices meet the MIL-PRF-38535 specified RHA levels and are marked with the appropriate RHA designator. Device class M RHA marked devices meet the MIL-PRF-38535, appendix A specified RHA levels and are marked with the appropriate RHA designator. A dash (-) indicates a non-RHA device.

1.2.2 Device type(s). The device type(s) identify the circuit function as follows:

<u>Device type</u>	<u>Generic number</u>	<u>Circuit function</u>
01	OP215A	Dual, precision JFET – input operational amplifier
02	OP215B	Dual, precision JFET – input operational amplifier
03	OP215B	Dual, precision JFET – input operational amplifier with balance adjust

1.2.3 Device class designator. The device class designator is a single letter identifying the product assurance level as listed below. Since the device class designator has been added after the original issuance of this drawing, device classes M and Q designators will not be included in the PIN and will not be marked on the device.

<u>Device class</u>	<u>Device requirements documentation</u>
M	Vendor self-certification to the requirements for MIL-STD-883 compliant, non-JAN class level B microcircuits in accordance with MIL-PRF-38535, appendix A
Q or V	Certification and qualification to MIL-PRF-38535

STANDARD MICROCIRCUIT DRAWING DEFENSE SUPPLY CENTER COLUMBUS COLUMBUS, OHIO 43218-3990	SIZE A		5962-88538
		REVISION LEVEL E	SHEET 2

1.2.4 Case outlines. The case outlines are as designated in MIL-STD-1835 and as follows:

<u>Outline letter</u>	<u>Descriptive designator</u>	<u>Terminals</u>	<u>Package style</u>
G	MACY1-X8	8	Can
P	GDIP1-T8 or CDIP2-T8	8	Dual-in-line
2	CQCC1-N20	20	Square leadless chip carrier

1.2.5 Lead finish. The lead finish is as specified in MIL-PRF-38535 for device classes Q and V or MIL-PRF-38535, appendix A for device class M.

1.3 Absolute maximum ratings. 1/

Supply voltage (V_S)	$\pm 22V$
Differential input voltage	$\pm 40 V$
Input voltage (V_{IN})	$\pm 20 V$ 2/
Output short-circuit duration	Indefinite
Internal power dissipation (P_D)	500 mW 3/
Junction temperature (T_J)	$+150^\circ C$
Storage temperature range	$-65^\circ C$ to $+150^\circ C$
Lead temperature (soldering, 60 seconds)	$+300^\circ C$
Thermal resistance, junction-to-case (θ_{JC})	See MIL-STD-1835

1.4 Recommended operating conditions.

Supply voltage (V_S)	$\pm 15 V$
Ambient operating temperature (T_A)	$-55^\circ C$ to $+125^\circ C$

1.5 Radiation features. 4/

Neutron (20 ns pulse)	5/
Maximum Total dose available (dose rate = 50 - 300 rad (Si)/s)	100 Krads (Si)
Dose rate latch-up	5/

- 1/ Stresses above the absolute maximum rating may cause permanent damage to the device. Extended operation at the maximum levels may degrade performance and affect reliability.
- 2/ Unless otherwise specified, the absolute maximum negative input voltage is equal to the negative power supply voltage.
- 3/ For case G at $T_A > 80^\circ C$, derate linearly at $7.1 \text{ mW}/^\circ C$. For case P at $T_A > 75^\circ C$, derate linearly at $6.7 \text{ mW}/^\circ C$. For case 2 at $T_A > 80^\circ C$, derate linearly at $7.5 \text{ mW}/^\circ C$.
- 4/ These parts may be dose rate sensitive in a space environment and may demonstrate enhanced low dose rate effects. Radiation end point limits for the noted parameters are guaranteed only for the conditions as specified in MIL-STD-883, method 1019, condition A.
- 5/ This test is to be conducted only when specified in the purchase order or contract.

STANDARD MICROCIRCUIT DRAWING DEFENSE SUPPLY CENTER COLUMBUS COLUMBUS, OHIO 43218-3990	SIZE A		5962-88538
		REVISION LEVEL E	SHEET 3

2. APPLICABLE DOCUMENTS

2.1 Government specification, standards, and handbooks. The following specification, standards, and handbooks form a part of this drawing to the extent specified herein. Unless otherwise specified, the issues of these documents are those cited in the solicitation or contract.

DEPARTMENT OF DEFENSE SPECIFICATION

MIL-PRF-38535 - Integrated Circuits, Manufacturing, General Specification for.

DEPARTMENT OF DEFENSE STANDARDS

MIL-STD-883 - Test Method Standard Microcircuits.
MIL-STD-1835 - Interface Standard Electronic Component Case Outlines.

DEPARTMENT OF DEFENSE HANDBOOKS

MIL-HDBK-103 - List of Standard Microcircuit Drawings.
MIL-HDBK-780 - Standard Microcircuit Drawings.

(Copies of these documents are available online at <http://assist.daps.dla.mil/quicksearch/> or <http://assist.daps.dla.mil> or from the Standardization Document Order Desk, 700 Robbins Avenue, Building 4D, Philadelphia, PA 19111-5094.)

2.2 Order of precedence. In the event of a conflict between the text of this drawing and the references cited herein, the text of this drawing takes precedence. Nothing in this document, however, supersedes applicable laws and regulations unless a specific exemption has been obtained.

3. REQUIREMENTS

3.1 Item requirements. The individual item requirements for device classes Q and V shall be in accordance with MIL-PRF-38535 and as specified herein or as modified in the device manufacturer's Quality Management (QM) plan. The modification in the QM plan shall not affect the form, fit, or function as described herein. The individual item requirements for device class M shall be in accordance with MIL-PRF-38535, appendix A for non-JAN class level B devices and as specified herein.

3.2 Design, construction, and physical dimensions. The design, construction, and physical dimensions shall be as specified in MIL-PRF-38535 and herein for device classes Q and V or MIL-PRF-38535, appendix A and herein for device class M.

3.2.1 Case outlines. The case outlines shall be in accordance with 1.2.4 herein.

3.2.2 Terminal connections. The terminal connections shall be as specified on figure 1.

3.2.3 Radiation exposure circuit. The radiation exposure circuit shall be as specified on figure 2.

3.3 Electrical performance characteristics and postirradiation parameter limits. Unless otherwise specified herein, the electrical performance characteristics and postirradiation parameter limits are as specified in table I and shall apply over the full ambient operating temperature range.

3.4 Electrical test requirements. The electrical test requirements shall be the subgroups specified in table IIA. The electrical tests for each subgroup are defined in table I.

3.5 Marking. The part shall be marked with the PIN listed in 1.2 herein. In addition, the manufacturer's PIN may also be marked. For packages where marking of the entire SMD PIN number is not feasible due to space limitations, the manufacturer has the option of not marking the "5962-" on the device. For RHA product using this option, the RHA designator shall still be marked. Marking for device classes Q and V shall be in accordance with MIL-PRF-38535. Marking for device class M shall be in accordance with MIL-PRF-38535, appendix A.

3.5.1 Certification/compliance mark. The certification mark for device classes Q and V shall be a "QML" or "Q" as required in MIL-PRF-38535. The compliance mark for device class M shall be a "C" as required in MIL-PRF-38535, appendix A.

STANDARD MICROCIRCUIT DRAWING DEFENSE SUPPLY CENTER COLUMBUS COLUMBUS, OHIO 43218-3990	SIZE A		5962-88538
		REVISION LEVEL E	SHEET 4

TABLE I. Electrical performance characteristics.

Test	Symbol	Conditions <u>1/ 2/</u> -55°C ≤ T _A ≤ +125°C V _S = ±15 V unless otherwise specified	Group A subgroups	Device type	Limits		Unit
					Min	Max	
Input offset voltage	V _{IO}	R _S = 50 Ω	1	01		±1.0	mV
				02,03		±2.0	
			2,3	01		±2.0	
				02,03		±3.0	
M,D,P,L,R	1	01		±3.0			
Input offset current	I _{IO}	T _J = +25°C, -55°C, V _{CM} = 0 V	1,3 <u>3/</u>	All		±50.0	pA
		T _J = +125°C, V _{CM} = 0 V	2			±8.0	nA
		M,D,P,L,R, V _{CM} = 0 V	1	01		±300	pA
Input bias current	I _{IB}	T _J = +25°C, -55°C, V _{CM} = 0 V	1,3 <u>3/</u>	01		±100	pA
				02,03		±200	
		T _J = +125°C, V _{CM} = 0 V	2	All		±10	nA
		M,D,P,L,R, V _{CM} = 0 V	1	01		±6	
Large signal voltage gain	A _{VO}	V _O = ±10 V, R _L ≥ 2 kΩ	4	01	150		V/mV
				02,03	750		
			5,6	All	30		
		M,D,P,L,R V _O = ±10 V, R _L = 2 kΩ	4	01	10		
Output voltage swing <u>4/</u>	V _O	R _L ≥ 2 kΩ	4	All	±11		V
		R _L ≥ 10 kΩ	5,6		±12		
Supply current	I _S	V _O = 0 V, T _A = +25°C	1	All		8.5	mA
		M,D,P,L,R, V _O = 0 V	1	01		8.5	

See footnotes at end of table.

STANDARD MICROCIRCUIT DRAWING DEFENSE SUPPLY CENTER COLUMBUS COLUMBUS, OHIO 43218-3990	SIZE A		5962-88538
		REVISION LEVEL E	SHEET 5

TABLE I. Electrical performance characteristics – Continued.

Test	Symbol	Conditions <u>1/ 2/</u> -55°C ≤ T _A ≤ +125°C V _S = ±15 V unless otherwise specified	Group A subgroups	Device type	Limits		Unit
					Min	Max	
Slew rate <u>4/</u>	SR	A _{VCL} = +1, R _L ≥ 2 kΩ, C _L = 100 pF	4	01	10.0		V/μs
			5,6		7.5		
			4	02,03	7.5		
			5,6		5.0		
Settling time <u>4/ 5/</u>	t _S	To 0.01 %, T _A = +25°C	9	All		3.0	μs
		To 0.05 %, T _A = +25°C				2.1	
		To 0.10 %, T _A = +25°C				1.8	
Common-mode <u>4/</u> rejection ratio	CMRR	V _{CM} = IVR = ±10.2 V	1	All	86		dB
			2,3		82		
Power supply rejection <u>4/</u> ratio	PSRR	V _S = ±10 V to ±16 V	1	01		51	μV/V
				02,03		80	
			2,3	All		100	
Input voltage range <u>4/ 6/</u>	IVR		1,2,3	All	±10.2		V
Gain bandwidth <u>4/ 7/</u> product	ABW	T _A = +25°C	4	All	3.5		MHz

- 1/ Devices supplied to this drawing have been characterized through all levels M, D, P, L, and R of irradiation. However, this device is only tested at the "R" level. Pre and Post irradiation values are identical unless otherwise specified in Table I. When performing post irradiation electrical measurements for any RHA level, T_A = +25°C.
- 2/ These parts may be dose rate sensitive in a space environment and may demonstrate enhanced low dose rate effects. Radiation end point limits for the noted parameters are guaranteed only for the conditions as specified in MIL-STD-883, method 1019, condition A.
- 3/ T_A = -55°C for I_{IO} and I_{IB} tests, subgroup 3, is guaranteed by T_A = +25°C test.
- 4/ This parameter not tested post radiation.
- 5/ Settling time is defined here for a unity gain inverter connection using 2 kΩ resistors. It is the time required for the error voltage (the voltage at the inverting input pin on the amplifier) to settle to within a specified percent of its final value from the time a 10 V step input is applied to the inverter.
- 6/ IVR test is defined as the V_{CM} range used for the CMRR test.
- 7/ Parameter guaranteed if not tested to the limits specified.

STANDARD MICROCIRCUIT DRAWING DEFENSE SUPPLY CENTER COLUMBUS COLUMBUS, OHIO 43218-3990	SIZE A		5962-88538
		REVISION LEVEL E	SHEET 6

Device types	01 and 02	01	03
Case outlines	G and P	2	2
Terminal number	Terminal symbol		
1	OUTPUT A	NC	NC
2	-INPUT A	OUTPUT A	-INPUT A
3	+INPUT A	NC	+INPUT A
4	-V _S	NC	BALANCE A
5	+INPUT B	-INPUT A	NC
6	-INPUT B	NC	-V _S
7	OUTPUT B	+INPUT A	NC
8	+V _S	NC	BALANCE B
9	---	NC	+INPUT B
10	---	-V _S	-INPUT B
11	---	NC	NC
12	---	+INPUT B	BALANCE B
13	---	NC	+V _S (B) (SEE NOTE 1)
14	---	NC	OUTPUT B
15	---	-INPUT B	NC
16	---	NC	NC
17	---	OUTPUT B	NC
18	---	NC	OUTPUT A
19	---	NC	+V _S (A) (SEE NOTE 1)
20	---	+V _S	BALANCE A

NOTE:

1. +V_S (A) and +V_S (B) internally connected.
2. NC = No connection

FIGURE 1. Terminal connections.

STANDARD MICROCIRCUIT DRAWING DEFENSE SUPPLY CENTER COLUMBUS COLUMBUS, OHIO 43218-3990	SIZE A		5962-88538
		REVISION LEVEL E	SHEET 7

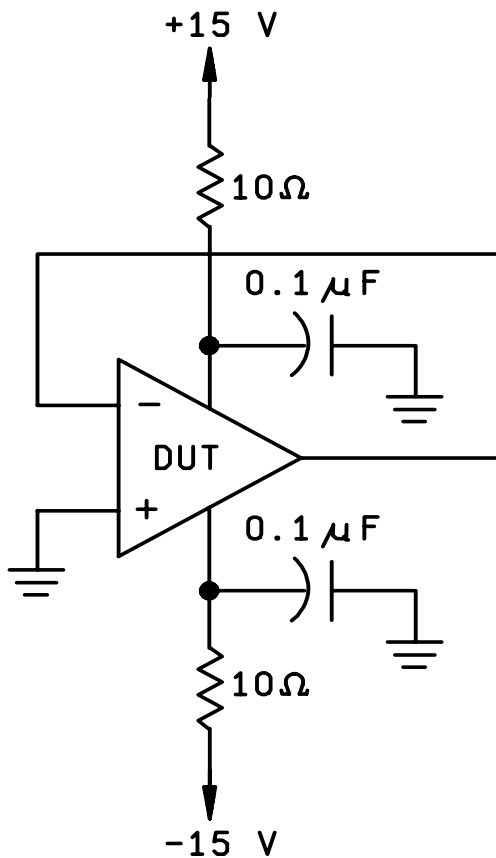

FIGURE 2. Radiation exposure circuit.

STANDARD MICROCIRCUIT DRAWING DEFENSE SUPPLY CENTER COLUMBUS COLUMBUS, OHIO 43218-3990	SIZE A		5962-88538
		REVISION LEVEL E	SHEET 8

3.6 Certificate of compliance. For device classes Q and V, a certificate of compliance shall be required from a QML-38535 listed manufacturer in order to supply to the requirements of this drawing (see 6.6.1 herein). For device class M, a certificate of compliance shall be required from a manufacturer in order to be listed as an approved source of supply in MIL-HDBK-103 (see 6.6.2 herein). The certificate of compliance submitted to DSCC-VA prior to listing as an approved source of supply for this drawing shall affirm that the manufacturer's product meets, for device classes Q and V, the requirements of MIL-PRF-38535 and herein or for device class M, the requirements of MIL-PRF-38535, appendix A and herein.

3.7 Certificate of conformance. A certificate of conformance as required for device classes Q and V in MIL-PRF-38535 or for device class M in MIL-PRF-38535, appendix A shall be provided with each lot of microcircuits delivered to this drawing.

3.8 Notification of change for device class M. For device class M, notification to DSCC-VA of change of product (see 6.2 herein) involving devices acquired to this drawing is required for any change that affects this drawing.

3.9 Verification and review for device class M. For device class M, DSCC, DSCC's agent, and the acquiring activity retain the option to review the manufacturer's facility and applicable required documentation. Offshore documentation shall be made available onshore at the option of the reviewer.

3.10 Microcircuit group assignment for device class M. Device class M devices covered by this drawing shall be in microcircuit group number 61 (see MIL-PRF-38535, appendix A).

4. VERIFICATION

4.1 Sampling and inspection. For device classes Q and V, sampling and inspection procedures shall be in accordance with MIL-PRF-38535 or as modified in the device manufacturer's Quality Management (QM) plan. The modification in the QM plan shall not affect the form, fit, or function as described herein. For device class M, sampling and inspection procedures shall be in accordance with MIL-PRF-38535, appendix A.

4.2 Screening. For device classes Q and V, screening shall be in accordance with MIL-PRF-38535, and shall be conducted on all devices prior to qualification and technology conformance inspection. For device class M, screening shall be in accordance with method 5004 of MIL-STD-883, and shall be conducted on all devices prior to quality conformance inspection.

4.2.1 Additional criteria for device class M.

a. Burn-in test, method 1015 of MIL-STD-883.

(1) Test condition A, B, C, or D. The test circuit shall be maintained by the manufacturer under document revision level control and shall be made available to the preparing or acquiring activity upon request. The test circuit shall specify the inputs, outputs, biases, and power dissipation, as applicable, in accordance with the intent specified in method 1015.

(2) $T_A = +125^\circ\text{C}$, minimum.

b. Interim and final electrical test parameters shall be as specified in table IIA herein.

4.2.2 Additional criteria for device classes Q and V.

a. The burn-in test duration, test condition and test temperature, or approved alternatives shall be as specified in the device manufacturer's QM plan in accordance with MIL-PRF-38535. The burn-in test circuit shall be maintained under document revision level control of the device manufacturer's Technology Review Board (TRB) in accordance with MIL-PRF-38535 and shall be made available to the acquiring or preparing activity upon request. The test circuit shall specify the inputs, outputs, biases, and power dissipation, as applicable, in accordance with the intent specified in method 1015 of MIL-STD-883.

b. Interim and final electrical test parameters shall be as specified in table IIA herein.

c. Additional screening for device class V beyond the requirements of device class Q shall be as specified in MIL-PRF-38535, appendix B.

STANDARD MICROCIRCUIT DRAWING DEFENSE SUPPLY CENTER COLUMBUS COLUMBUS, OHIO 43218-3990	SIZE A		5962-88538
		REVISION LEVEL E	SHEET 9

TABLE IIA. Electrical test requirements.

Test requirements	Subgroups (in accordance with MIL-STD-883, method 5005, table I)	Subgroups (in accordance with MIL-PRF-38535, table III)	
	Device class M	Device class Q	Device class V
Interim electrical parameters (see 4.2)	1	1	1
Final electrical parameters (see 4.2)	1,2,3,4,5,6 <u>1/</u>	1,2,3,4,5,6 <u>1/</u>	1,2,3, <u>1/ 2/</u> 4,5,6
Group A test requirements (see 4.4)	1,2,3,4,5,6,9	1,2,3,4,5,6,9	1,2,3,4,5,6,9
Group C end-point electrical parameters (see 4.4)	1	1	1 <u>2/</u>
Group D end-point electrical parameters (see 4.4)	1	1	1
Group E end-point electrical parameters (see 4.4)	---	---	1,4

1/ PDA applies to subgroup 1.

2/ Delta limits as specified in table IIB shall be required where specified and the delta limits shall be computed with reference to the previous interim electrical parameters.

TABLE IIB. 240 hour burn in and Group C end-point electrical parameters.

Test	Device type	Limit		Delta		Unit
		Min	Max	Min	Max	
V _{OS}	01	-2.0	+2.0	-1.0	+1.0	mV
	02	-3.0	+3.0	-1.0	+1.0	
	03	-5.0	+5.0	-1.0	+1.0	
I _{IB}	01	-150	+150	-75	+75	pA
	02	-300	+300	-100	+100	
	03	-450	+450	-150	+150	

4.3 Qualification inspection for device classes Q and V. Qualification inspection for device classes Q and V shall be in accordance with MIL-PRF-38535. Inspections to be performed shall be those specified in MIL-PRF-38535 and herein for groups A, B, C, D, and E inspections (see 4.4.1 through 4.4.4).

4.4 Conformance inspection. Technology conformance inspection for classes Q and V shall be in accordance with MIL-PRF-38535 including groups A, B, C, D, and E inspections and as specified. Quality conformance inspection for device class M shall be in accordance with MIL-PRF-38535, appendix A and as specified herein. Inspections to be performed for device class M shall be those specified in method 5005 of MIL-STD-883 and herein for groups A, B, C, D, and E inspections (see 4.4.1 through 4.4.4).

STANDARD MICROCIRCUIT DRAWING DEFENSE SUPPLY CENTER COLUMBUS COLUMBUS, OHIO 43218-3990	SIZE A		5962-88538
		REVISION LEVEL E	SHEET 10

4.4.1 Group A inspection.

- a. Tests shall be as specified in table IIA herein.
- b. Subgroups 7, 8, 10, and 11 in table I, method 5005 MIL-STD-883 shall be omitted.

4.4.2 Group C inspection. The group C inspection end-point electrical parameters shall be as specified in table IIA herein.

4.4.2.1 Additional criteria for device class M. Steady-state life test conditions, method 1005 of MIL-STD-883:

- a. Test condition A, B, C, or D. The test circuit shall be maintained by the manufacturer under document revision level control and shall be made available to the preparing or acquiring activity upon request. The test circuit shall specify the inputs, outputs, biases, and power dissipation, as applicable, in accordance with the intent specified in method 1005 of MIL-STD-883.
- b. $T_A = +125^{\circ}\text{C}$, minimum.
- c. Test duration: 1,000 hours, except as permitted by method 1005 of MIL-STD-883.

4.4.2.2 Additional criteria for device classes Q and V. The steady-state life test duration, test condition and test temperature, or approved alternatives shall be as specified in the device manufacturer's QM plan in accordance with MIL-PRF-38535. The test circuit shall be maintained under document revision level control by the device manufacturer's TRB in accordance with MIL-PRF-38535 and shall be made available to the acquiring or preparing activity upon request. The test circuit shall specify the inputs, outputs, biases, and power dissipation, as applicable, in accordance with the intent specified in method 1005 of MIL-STD-883.

4.4.3 Group D inspection. The group D inspection end-point electrical parameters shall be as specified in table IIA herein.

4.4.4 Group E inspection. Group E inspection is required only for parts intended to be marked as radiation hardness assured (see 3.5 herein). RHA levels for device classes M, Q, and V shall be as specified in MIL-PRF-38535. End-point electrical parameters shall be as specified in table IIA herein.

4.4.4.1 Total dose irradiation testing. Total dose irradiation testing shall be performed in accordance with MIL-STD-883 method 1019, condition A and as specified herein.

4.4.4.1.1 Accelerated aging test. Accelerated aging tests shall be performed on all devices requiring a RHA level greater than 5k rads(Si). The post-anneal end-point electrical parameter limits shall be as specified in table I herein and shall be the pre-irradiation end-point electrical parameter limit at $25^{\circ}\text{C} \pm 5^{\circ}\text{C}$. Testing shall be performed at initial qualification and after any design or process changes which may affect the RHA response of the device.

4.4.4.2 Dose rate burnout. When required by the customer, neutron testing shall be performed in accordance with test method 1017 of MIL-STD-883 and herein. All device classes must meet the post irradiation end-point electrical parameter limits as defined in table I, for the subgroups specified in Table IIA herein at $T_A = +25^{\circ}\text{C} \pm 5^{\circ}\text{C}$ after an exposure of 2×10^{12} neutrons/cm² (minimum).

5. PACKAGING

5.1 Packaging requirements. The requirements for packaging shall be in accordance with MIL-PRF-38535 for device classes Q and V or MIL-PRF-38535, appendix A for device class M.

STANDARD MICROCIRCUIT DRAWING DEFENSE SUPPLY CENTER COLUMBUS COLUMBUS, OHIO 43218-3990	SIZE A		5962-88538
		REVISION LEVEL E	SHEET 11

6. NOTES

6.1 Intended use. Microcircuits conforming to this drawing are intended for use for Government microcircuit applications (original equipment), design applications, and logistics purposes.

6.1.1 Replaceability. Microcircuits covered by this drawing will replace the same generic device covered by a contractor-prepared specification or drawing.

6.2 Configuration control of SMD's. All proposed changes to existing SMD's will be coordinated with the users of record for the individual documents. This coordination will be accomplished using DD Form 1692, Engineering Change Proposal.

6.3 Record of users. Military and industrial users should inform Defense Supply Center Columbus (DSCC) when a system application requires configuration control and which SMD's are applicable to that system. DSCC will maintain a record of users and this list will be used for coordination and distribution of changes to the drawings. Users of drawings covering microelectronic devices (FSC 5962) should contact DSCC-VA, telephone (614) 692-0544.

6.4 Comments. Comments on this drawing should be directed to DSCC-VA, Columbus, Ohio 43218-3990, or telephone (614) 692-0547.

6.5 Abbreviations, symbols, and definitions. The abbreviations, symbols, and definitions used herein are defined in MIL-PRF-38535 and MIL-HDBK-1331.

6.6 Sources of supply.

6.6.1 Sources of supply for device classes Q and V. Sources of supply for device classes Q and V are listed in QML-38535. The vendors listed in QML-38535 have submitted a certificate of compliance (see 3.6 herein) to DSCC-VA and have agreed to this drawing.

6.6.2 Approved sources of supply for device class M. Approved sources of supply for class M are listed in MIL-HDBK-103. The vendors listed in MIL-HDBK-103 have agreed to this drawing and a certificate of compliance (see 3.6 herein) has been submitted to and accepted by DSCC-VA.

STANDARD MICROCIRCUIT DRAWING DEFENSE SUPPLY CENTER COLUMBUS COLUMBUS, OHIO 43218-3990	SIZE A		5962-88538
		REVISION LEVEL E	SHEET 12

STANDARD MICROCIRCUIT DRAWING BULLETIN

DATE: 05-08-10

Approved sources of supply for SMD 5962-88538 are listed below for immediate acquisition information only and shall be added to MIL-HDBK-103 and QML-38535 during the next revision. MIL-HDBK-103 and QML-38535 will be revised to include the addition or deletion of sources. The vendors listed below have agreed to this drawing and a certificate of compliance has been submitted to and accepted by DSCC-VA. This information bulletin is superseded by the next dated revision of MIL-HDBK-103 and QML-38535. DSCC maintains an online database of all current sources of supply at <http://www.dscclia.mil/Programs/Smcr/>.

Standard microcircuit drawing PIN <u>1/</u>	Vendor CAGE number	Vendor similar PIN <u>2/</u>
5962-8853801GA	<u>3/</u>	OP215AJ/883
	<u>3/</u>	OP215AH/883
5962-8853801PA	24355	OP215AZ/883
	<u>3/</u>	OP215AJ8/883
5962-88538012A	24355	OP215ARC/883C
5962-8853801VGA	24355	OP215AJ/QMLV
5962-8853801VPA	24355	OP215AZ/QMLV
5962-8853801V2A	24355	OP215ARC/QMLV
5962-8853802GA	24355	OP215BJ/883
	<u>3/</u>	OP215AH/883
5962-8853802PA	<u>3/</u>	OP215BZ/883
	<u>3/</u>	OP215AJ8/883
5962-88538032A	<u>3/</u>	OP215BRC/883

STANDARD MICROCIRCUIT DRAWING BULLETIN – Continued.

Standard microcircuit drawing PIN <u>1/</u>	Vendor CAGE number	Vendor similar PIN <u>2/</u>
5962R8853801VGA	24355	OP215AJ/QMLR
5962R8853801VPA	24355	OP215AZ/QMLR
5962R8853801V2A	24355	OP215ARC/QMLR

1/ The lead finish shown for each PIN representing a hermetic package is the most readily available from the manufacturer listed for that part. If the desired lead finish is not listed contact the vendor to determine its availability.

2/ Caution. Do not use this number for item acquisition. Items acquired to this number may not satisfy the performance requirements of this drawing.

3/ Not available from an approved source of supply.

Vendor CAGE number

24355

Vendor name and address

Analog Devices
 RT 1 Industrial Park
 P.O. Box 9106
 Norwood, MA 02062
 Point of contact: 1500 Space Park Drive
 P.O. Box 58020
 Santa Clara, CA 95050-8020

The information contained herein is disseminated for convenience only and the Government assumes no liability whatsoever for any inaccuracies in the information bulletin.