

FEATURES

- 5V Output $\pm 0.3\%$ Max.
- Temperature Voltage Output $2.1\text{mV}/^\circ\text{C}$
- Adjustment Range $\pm 3\%$ Min.
- Low Supply Current 1.4mA Max.
- High-Load Driving Capability 20mA
- No External Components
- Short Circuit Proof
- Laser-Trimmed to High Accuracies
- Output Sources or Sinks Current

APPLICATIONS

- Precision Regulators
- Temperature Controllers
- A/D and D/A Converters
- Constant Current Sources
- V to F Converters

DESCRIPTION

The REF-02 is a 5V precision bandgap voltage reference which provides a stable output voltage over a wide range of operating conditions, i.e. input voltage, output current, ambient temperature, etc. The output voltage can be adjusted within $\pm 6\%$. REF-02 also provides an output which varies linearly with temperature. Hence, the device can also be used in temperature controller applications. The devices can also be stacked to provide higher voltage references, such as 25, 40, 100V, etc., as long as the total usable current is not exceeded. REF-02 is available in commercial and military temperature ranges.

ORDERING INFORMATION†

$T_A = 25^\circ\text{C}$ $\Delta V_O \text{ MAX}$ (mV)	PACKAGE					OPER. TEMP. RANGE
	TO-99 8-PIN	HERMETIC DIP 8-PIN	PLASTIC DIP 8-PIN	PLASTIC SOIC 8-PIN	LCC	
± 15	REF02AJ*	REF02AZ*				MIL COM
± 15	REF02EJ	REF02EZ				COM
± 25	REF02J*	REF02Z*			REF02RC/883	MIL
± 25	REF02HJ	REF02HZ	REF02HP	REF02HS		COM
± 50	REF02CJ	REF02CZ	REF02CP	REF02CS		COM
± 100	REF02DJ	REF02DZ	REF02DP	REF02DS		COM

*For devices processed in total compliance to MIL-STD-883, add /883 after part number. Consult factory for 883 data sheet.

†All commercial and industrial temperature range parts are available with burn-in.

REPRODUCED BY
 THE UNIVERSITY OF MICHIGAN
 LIBRARY

Pin Connections (Top View)

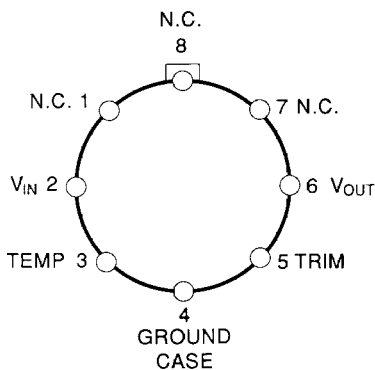

TO-99
(J-Suffix)

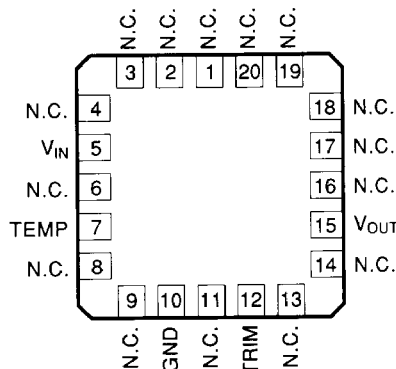

REF-01RC/883
LCC
(RC-Suffix)

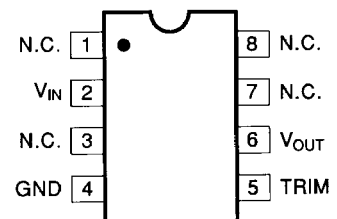

EPOXY MINI DIP
(P-Suffix)
8-PIN HERMETIC DIP
(Z-Suffix)
8-PIN PLASTIC SOIC
(S-Suffix)

ABSOLUTE MAXIMUM RATINGS (Note 2)

- Input Voltage
 - REF-02, A, E, H, RC, All DICE 40V
 - REF-02 C, D 30V
- Power Dissipation (Note 1) 500mW
- Output Short-Circuit Duration
(to Ground or V_{IN}) Indefinite
- Storage Temperature Range
 - J, RC, and Z Packages -65°C to $+150^{\circ}\text{C}$
 - P Package -65°C to $+125^{\circ}\text{C}$
- Operating Temperature Range
 - REF-02A, REF-02, REF-02RC -55°C to $+125^{\circ}\text{C}$
 - REF-02E, REF-02H 0°C to $+70^{\circ}\text{C}$
 - REF-02C, REF-02D 0°C to $+70^{\circ}\text{C}$
- DICE Junction Temperature (T_j) -65°C to $+150^{\circ}\text{C}$
- Lead Temperature (Soldering, 60 sec.) 300°C

NOTES:

1. See table for maximum ambient temperature rating and derating factor.

PACKAGE TYPE	MAXIMUM AMBIENT TEMPERATURE FOR RATING	DERATE ABOVE MAXIMUM AMBIENT TEMPERATURE
TO-99 (J)	80°C	7.1mW/°C
8-Pin Hermetic DIP (Z)	75°C	6.7mW/°C
8-Pin Plastic DIP (P)	36°C	5.6mW/°C
LCC (RC)	72°C	7.8mW/°C

2. Absolute maximum ratings apply to both DICE and packaged parts, unless otherwise noted.

Simplified Schematic Diagram

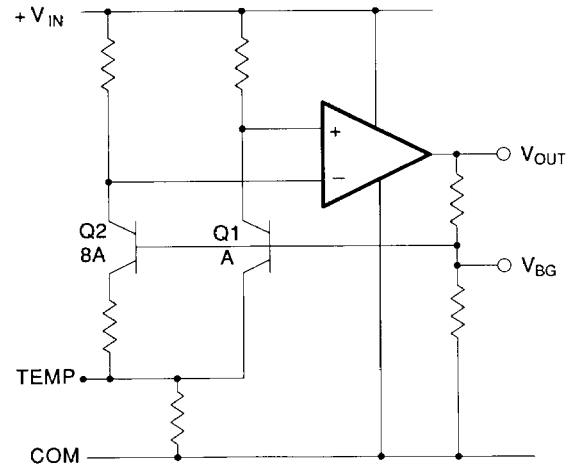

Die Dimensions and Pad Connections

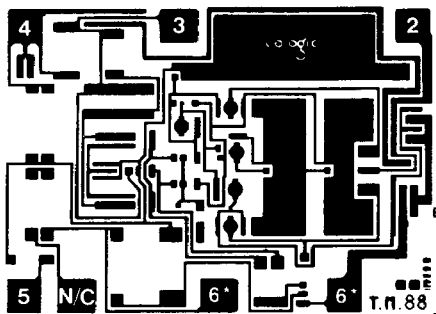

- 2. V_{IN}
- 3. TEMP
- 4. GND
- 6. V_{OUT}^*

*The two bonding pads are connected to pin 6.

DIE SIZE 0.067 x 0.05 inch, 3550 sq. mils
(1.702 x 1.27mm, 2.16 sq. mm)

ELECTRICAL CHARACTERISTICS at $V_{IN} = +15V$, $T_A = 25^\circ C$, unless otherwise noted.

PARAMETER	SYMBOL	CONDITIONS	REF-02A/E			REF-02/H			UNITS
			MIN.	TYP.	MAX.	MIN.	TYP.	MAX.	
Output Voltage	V_O	$I_L = 0$	4.985	5.000	5.015	4.975	5.000	5.025	V
Output Adjustment Range	ΔV_{trim}	$R_p = 10k\Omega$	± 3	± 6	—	± 3	± 6	—	%
Output Voltage Noise	e_{np-p}	0.1Hz to 10Hz (Note 7)	—	10	15	—	10	15	μV_{p-p}
Line Regulation (Note 2)		$V_{IN} = 8V$ to 33V	—	0.006	0.010	—	0.006	0.010	%/V
Load Regulation (Note 4)		$I_L = 0$ to 10mA	—	0.005	0.010	—	0.006	0.010	%/mA
Turn-on Settling Time	t_{ON}	$T_o \pm 0.1\%$ of final value	—	5	—	—	5	—	μs
Quiescent Supply Current	I_{SY}	No Load	—	1.0	1.4	—	1.0	1.4	mA
Load Current	I_L		10	21	—	10	21	—	mA
Sink Current	I_S		-5	-10	—	-5	-10	—	mA
Short-Circuit Current	I_{SC}	$V_O = 0$	—	30	—	—	30	—	mA
Temperature Voltage Output	V_T	(Note 3)	—	630	—	—	630	—	mV

ELECTRICAL CHARACTERISTICS at $V_{IN} = +15V$, $-55^\circ C \leq T_A \leq +125^\circ C$ for REF-02A and REF-02, $0^\circ C \leq T_A \leq +70^\circ C$ for REF-02E and REF-02H, $I_L = 0mA$, unless otherwise noted.

PARAMETER	SYMBOL	CONDITIONS	REF-02A/E			REF-02/H			UNITS
			MIN.	TYP.	MAX.	MIN.	TYP.	MAX.	
Output Voltage Change with Temperature (Notes 4, 5)	ΔV_{OT}	$0^\circ C \leq T_A \leq +70^\circ C$ $-55^\circ C \leq T_A \leq +125^\circ C$	—	0.02	0.06	—	0.07	0.17	%
Output Voltage Temperature Coefficient	TCV_O	(Note 6)	—	3	8.5	—	10	25	ppm/ $^\circ C$
Change in V_O Temperature Coefficient with Output Adjustment		$R_p = 10k\Omega$	—	0.7	—	—	0.7	—	ppm/%
Line Regulation ($V_{IN} = 8V$ to 33V) (Note 2)		$0^\circ C \leq T_A \leq +70^\circ C$ $-55^\circ C \leq T_A \leq +125^\circ C$	—	0.007	0.012	—	0.007	0.012	%/V
Load Regulation ($I_L = 0$ to 8mA) (Note 2)		$0^\circ C \leq T_A \leq +70^\circ C$ $-55^\circ C \leq T_A \leq +125^\circ C$	—	0.006	0.010	—	0.007	0.012	%/V
Temperature Voltage Output Temperature Coefficient	TCV_T	(Note 3)	—	2.1	—	—	2.1	—	mV/ $^\circ C$

NOTES:

- Guaranteed by design
- Line and Load Regulation specifications include the effect of self heating.
- Limit current in or out of pin 3 to 50nA and capacitance on pin 3 to 30pF.
- ΔV_{OT} is defined as the absolute difference between the maximum output voltage and the minimum output voltage over the specified temperature range expressed as a percentage of 5V:

$$\Delta V_{OT} = \left| \frac{V_{MAX} - V_{MIN}}{5V} \right| \times 100$$

- ΔV_{OT} specification applies trimmed to +5.000V or untrimmed.
- TCV_O is defined as ΔV_{OT} divided by the temperature range, i.e.,

$$TCV_O = \frac{\Delta V_{OT}}{70^\circ C}$$

- Sample tested.

ELECTRICAL CHARACTERISTICS at $V_{IN} = +15V$, $T_A = 25^\circ C$, unless otherwise noted.

PARAMETER	SYMBOL	CONDITIONS	REF-02C			REF-02D			UNITS	
			MIN.	TYP.	MAX.	MIN.	TYP.	MAX.		
Output Voltage	V_O	$I_L = 0$	4.950	5.000	5.050	4.900	5.000	5.100	V	
Output Adjustment Range	ΔV_{trim}	$R_p = 10k\Omega$	± 2.7	± 6.0	—	± 2.0	± 6.0	—	%	
Output Voltage Noise	e_{np-p}	0.1Hz to 10Hz (Note 7)	—	12	18	—	12	—	μV_{p-p}	
Line Regulation (Note 2)		$V_{IN} = 8V$ to 30V	—	0.009	0.015	—	0.010	0.04	%/V	
Load Regulation (Note 4)		$I_L = 0$ to 8mA $I_L = 0$ to 4mA	—	0.006	0.015	—	—	0.015	0.04	%/mA
Turn-on Settling Time	t_{ON}	$T_o \pm 0.1\%$ of final value	—	5	—	—	5	—	μs	
Quiescent Supply Current	I_{SY}	No Load	—	1.0	1.6	—	1.0	2.0	mA	
Load Current	I_L		8	21	—	8	21	—	mA	
Sink Current	I_S		-5	-10	—	-5	-10	—	mA	
Short-Circuit Current	I_{SC}	$V_O = 0$	—	30	—	—	30	—	mA	
Temperature Voltage Output	V_T	(Note 3)	—	630	—	—	630	—	mV	

ELECTRICAL CHARACTERISTICS at $V_{IN} = +15V$, $0^{\circ}C \leq T_A \leq +70^{\circ}C$ and $I_L = 0mA$, unless otherwise noted.

PARAMETER	SYMBOL	CONDITIONS	REF-02C			REF-02D			UNITS
			MIN.	TYP.	MAX.	MIN.	TYP.	MAX.	
Output Voltage Change with Temperature	ΔV_{OT}	(Notes 4 and 5)	—	0.14	0.45	—	0.49	1.7	%
Output Voltage Temperature Coefficient	TCV_O	(Note 6)	—	20	65	—	70	250	ppm/ $^{\circ}C$
Change in V_O Temperature Coefficient with Output Adjustment		$R_p = 10k\Omega$	—	0.7	—	—	0.7	—	ppm/%
Line Regulation (Note 2)		$V_{IN} = 8V$ to $30V$	—	0.011	0.018	—	0.012	0.005	%/V
Load Regulation (Note 2)		$I_L = 0$ to $5mA$	—	0.008	0.018	—	0.016	0.005	%/V
Temperature Voltage Output Temperature Coefficient	TCV_T	(Note 3)	—	2.1	—	—	2.1	—	mV/ $^{\circ}C$

NOTES:

1. Guaranteed by design
2. Line and Load Regulation specifications include the effect of self heating.
3. Limit current in or out of pin 3 to 50nA and capacitance on pin 3 to 30pF.
4. ΔV_{OT} is defined as the absolute difference between the maximum output voltage and the minimum output voltage over the specified temperature range expressed as a percentage of 5V:

$$\Delta V_{OT} = \left| \frac{V_{MAX} - V_{MIN}}{5V} \right| \times 100$$

5. ΔV_{OT} specification applies trimmed to +5.000V or untrimmed.
6. TCV_O is defined as ΔV_{OT} divided by the temperature range, i.e.,

$$TCV_O = \frac{\Delta V_{OT}}{70^{\circ}C}$$

7. Sample tested.