

# Customer Information Sheet

DRAWING No.: M80-5L1XXXXMC-00-000-00-000 SHT 2 OF 2

IF IN DOUBT - ASK

©

NOT TO SCALE

THIRD ANGLE PROJECTION

ALL DIMENSIONS IN mm

**SPECIFICATIONS:**

**MATERIAL:**  
 MOULDING = GLASS-FILLED PPS,  
 UL94V-0, BLACK  
 CONTACT = PHOSPHOR BRONZE  
 IOILOK RETAINER = STAINLESS STEEL  
**FINISH (CONTACTS):**  
 05 = 0.75µ GOLD ALL OVER  
 22 = 0.75µ GOLD ON CONTACT AREA,  
 3µ TIN/LEAD ON TAILS  
 42 = 0.75µ GOLD ON CONTACT AREA,  
 3µ 100% TIN OVER NICKEL ON TAILS

**ELECTRICAL:**  
 CURRENT RATING AT 25°C = 3.0A MAX  
 CURRENT RATING AT 85°C = 2.2A MAX  
 WORKING VOLTAGE = 120V AC/DC  
 VOLTAGE PROOF = 360V AC/DC  
 CONTACT RESISTANCE = 25 mΩ MAX  
 INSULATION RESISTANCE = 100 MΩ MIN

**MECHANICAL:**  
 DURABILITY = 500 OPERATIONS  
**ENVIRONMENTAL:**  
 TEMPERATURE RANGE = -55°C TO +125°C

**PACKING:**  
 TUBE  
 FOR COMPLETE SPECIFICATION, SEE COMPONENT  
 SPECIFICATION C005XX (LATEST ISSUE)

**NOTES:**  
 1. ALL PART LABELLING TO BE AS ORDER CODE,  
 EITHER WITH TRAILING ZEROS OR LEFT BLANK  
 AS PER ORDER CODE EXAMPLES 1 AND 2.

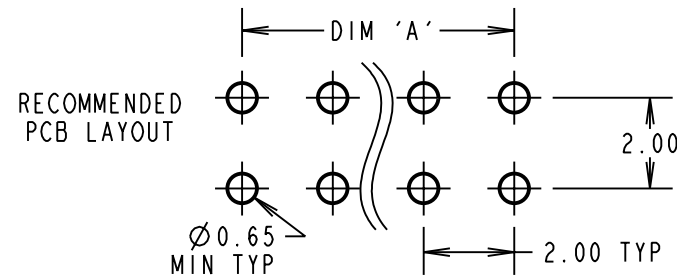
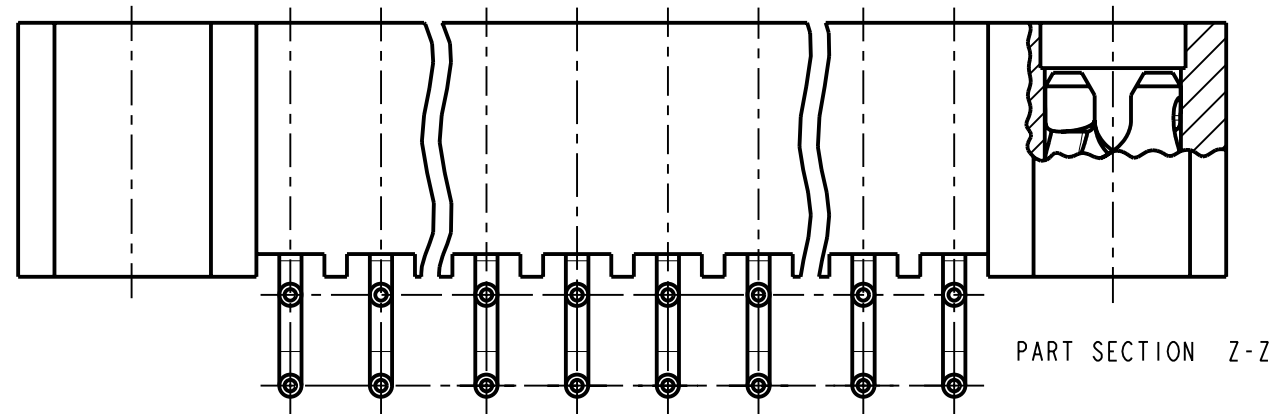
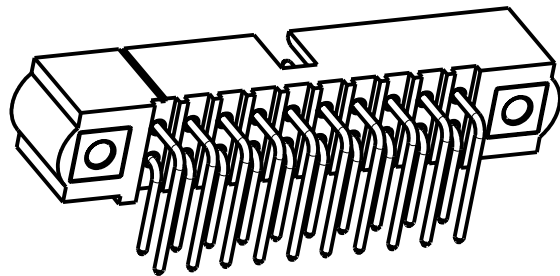
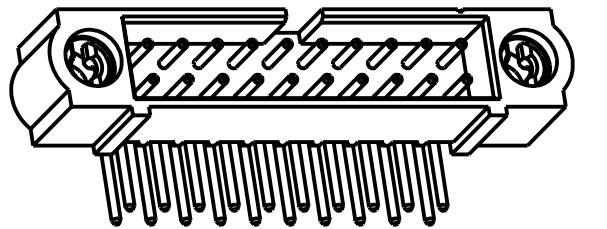
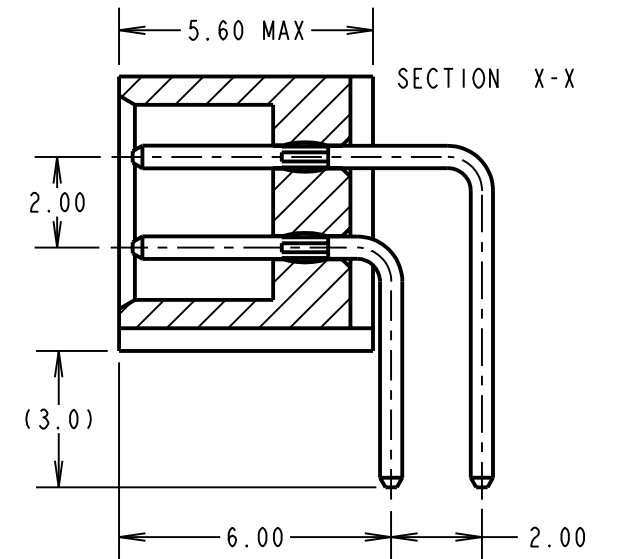
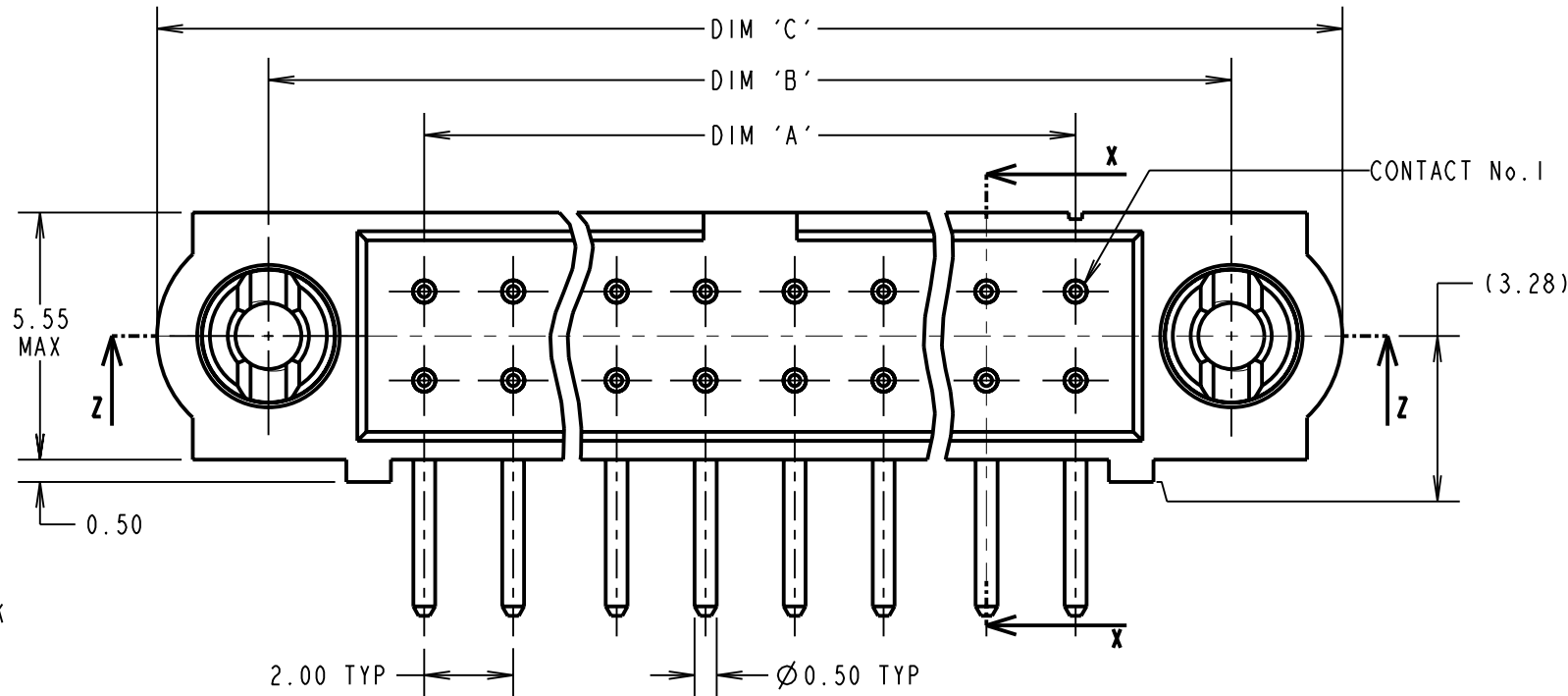

ORDER CODE:  
**M80-5L1XXXXMC-00-000-00-000**

TOTAL No. OF CONTACTS  
 04 TO 50  
 (EVEN NUMBERS ONLY)

**FINISH**  
 05 - ALL OVER GOLD  
 22 - GOLD ON CONTACT AREA / TIN/LEAD ON TAIL  
 42 - GOLD ON CONTACT AREA / 100% TIN OVER NICKEL ON TAIL

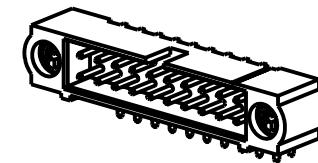

DIMENSION	CALCULATION
DIM 'A'	TOTAL No. OF CONTACTS - 2
DIM 'B'	TOTAL No. OF CONTACTS + 5
DIM 'C'	TOTAL No. OF CONTACTS + 10

EXAMPLE ORDER CODE 1: CONNECTOR WITH 20 CONTACTS,  
 GOLD ON CONTACT AREA AND 100% TIN OVER NICKEL ON TAIL

**M80-5L12042MC-00-000-00-000**

DIM 'A' = 18.00mm, DIM 'B' = 25.00mm, DIM 'C' = 30mm.

EXAMPLE ORDER CODE 2: CONNECTOR WITH 20 CONTACTS,  
 GOLD ON CONTACT AREA AND 100% TIN OVER NICKEL ON TAIL

**M80-5L12042MC**

DIM 'A' = 18.00mm, DIM 'B' = 25.00mm, DIM 'C' = 30mm.

**HARWIN**

HARWIN USA TEL: 603 893 5376 FAX: 603 893 5396 mis@harwin.com	HARWIN Europe (UK) TEL: 023 9231 4545 FAX: 023 9231 4590 mis@harwin.co.uk	HARWIN Asia TEL: +65 6 779 4909 FAX: +65 6 779 3868 mis@harwin.com.sg
--	--	--

THIS DRAWING AND ANY  
 INFORMATION OR DESCRIPTIVE  
 MATTER SET OUT HEREON ARE  
 CONFIDENTIAL AND COPYRIGHT  
 PROPERTY OF THE HARWIN  
 GROUP AND MUST NOT BE  
 DISCLOSED, LOANED, COPIED  
 OR USED FOR MANUFACTURING,  
 TENDERING OR FOR ANY  
 OTHER PURPOSE WITHOUT  
 THEIR WRITTEN PERMISSION.

**TOLERANCES**  
 X. = ±1mm  
 X.X = ±0.25mm  
 X.XX = ±0.10mm  
 X.XXX = ±0.01mm  
 ANGLES = ±5°  
 UNLESS STATED

**MATERIAL:**  
 SEE ABOVE  
**FINISH:**  
 SEE ABOVE  
**S/AREA:**  
 mm<sup>2</sup>

**TITLE:** DATAMATE J-TEK DIL HORIZ  
 3mm PC-TAIL MALE ASSY WITH  
 IOILOK RETAINERS

**DRAWING NUMBER:** M80-5L1XXXXMC,  
**M80-5L1XXXXMC-00-000-00-000** SHT 2 OF 2

CP	1	02.09.10	10870
NAME	ISS.	DATE	C/NOTE
APPROVED: C.PENROSE			
CHECKED: R.ADDE			
DRAWN: S.FLOWER			
CUSTOMER REF.:			
ASSEMBLY DRG:			