



W83195BR-25

W83195BG-25

**Step-less Frequency Solano 815 Clock
Gen. 3-DIMM, with S.S.T.**

Date: 10/05/2007 Revision: 2.1

W83195BR-25/W83195BG-25



W83195BR-25/W83195BG-25 Data Sheet Revision History

	PAGES	DATES	VERSION	WEB VERSION	MAIN CONTENTS
1	n.a.			n.a.	All of the versions before 0.50 are for internal use.
2	n.a.	02/Apr	1.0	1.0	Change version and version on web site to 1.0
3	All	02/19/2003	2.0	2.0	Update new form
4		10/05/2007	2.1	-	Add lead-free part number W83195BG-25
5					
6					
7					
8					
9					
10					

W83195BR-25/W83195BG-25



Table of Contents-

1.	GENERAL DESCRIPTION	1
2.	PRODUCT FEATURES	1
3.	PIN CONFIGURATION	2
4.	PIN DESCRIPTION.....	3
4.1	Crystal I/O.....	3
4.2	CPU, SDRAM, PCI, IOAPIC Clock Outputs.....	3
4.3	I2C Control Interface	4
4.4	Fixed Frequency Outputs.....	4
4.5	Power Pins.....	5
5.	FREQUENCY SELECTION BY HARDWARE	6
6.	SERIAL CONTROL REGISTERS.....	7
6.1	Register 0: CPU Frequency Select Register.....	9
6.2	Register 1: CPU Clock Register (1 = Active, 0 = Inactive).....	9
6.3	Register 2: SDRAM Clock Register (1 = Active, 0 = Inactive).....	9
6.4	Register 3: PCI Clock Register (1 = Active, 0 = Inactive)	10
6.5	Register 4: Additional Register (1 = Active, 0 = Inactive).....	10
6.6	Register 5: SDRAM Clock Register (1 = Active, 0 = Inactive).....	10
6.7	Register 6 Watchdog Timer Register	11
6.8	Register 7: M/N Program Register	11
6.9	Register 8: M/N Program Register	11
6.10	Register 9: Spread Spectrum Programming Register	12
6.11	Register 10: Divisor and Step-less Enable Register.....	12
6.12	Register 11: Winbond Chip ID Register (Read Only).....	13
6.13	Register 12: Winbond Chip ID Register (Read Only).....	13
7.	SPECIFICATIONS	14
7.1	Absolute Maximum Ratings	14
7.2	Electronical Characteristics—Input/Output.....	14
7.3	Electronical Characteristics of CPU Clock	15
7.4	Electronical Characteristics of 3V66 Clock.....	15
7.5	Electronical Characteristics of SDRAM Clock.....	16
7.6	Electronical Characteristics of PCI Clock	16
7.7	Electronical Characteristics of 48MHz, REF Clock.....	17
8.	ORDERING INFORMATION.....	18

W83195BR-25/W83195BG-25



200MHZ 3-DIMM CLOCK FOR SOLANO CHIPSET

9.	HOW TO READ THE TOP MARKING.....	18
10.	PACKAGE DRAWING AND DIMENSIONS.....	19

W83195BR-25/W83195BG-25



1. GENERAL DESCRIPTION

The W83195BR-25 is a Clock Synthesizer for Intel 815 Solano chipset. W83195BR-25 provides all clocks required for high-speed RISC or CISC microprocessor and also provides 64 different frequencies of CPU, SDRAM, PCI, 3V66, IOAPIC clocks frequency setting. All clocks are externally selectable with smooth transitions.

The W83195BR-25 provides I²C serial bus interface to program the registers to enable or disable each clock outputs and provides 0.25% and 0.5% center type spread spectrum to reduce EMI.

The W83195BR-25 provides step less frequency programming by controlling the VCO freq. and the clock output divisor ratio. Also skew of CPU, SDRAM and 3V66 clock outputs are programmable. A watch dog timer is quipped and when time out, the RESET# pin will output 4ms pulse signal.

The W83195BR-25 accepts a 14.318 MHz reference crystal as its input and runs on a 3.3V supply. High drive PCI and SDRAM CLOCK outputs typically provide greater than 1 V/ns slew rate into 30 pF loads. CPU CLOCK outputs typically provide better than 1 V/ns slew rate into 20 pF loads as maintaining 50± 5% duty cycle. The fixed frequency outputs as REF, 24MHz, and 48 MHz provide better than 0.5V/ns slew rate.

2. PRODUCT FEATURES

- 2 CPU clocks (2.5V)
- 3 3V-66 clocks (3.3V)
- 12 SDRAM clocks for 3 DIMMs(3.3V)
- 8 PCI synchronous clocks.
- Optional single or mixed supply:
(VDDR = VDDP=VDDS = VDD48 = VDD3 = 3.3V, VDDA=VDDC=2.5V)
- Skew form CPU to PCI clock -1 to 4 ns, center 2.6 ns
- Smooth frequency switch with selections from 66.8 to 200MHz
- I²C 2-Wire serial interface and I²C read back
- 0.25% center and 0.5% center type spread spectrum
- Programmable registers to enable/stop each output and select modes
(Mode as Tri-state or Normal)
- 48 MHz for USB
- 24 MHz for super I/O
- Packaged in 56-pin SSOP

W83195BR-25/W83195BG-25



200MHZ 3-DIMM CLOCK FOR SOLANO CHIPSET

3. PIN CONFIGURATION

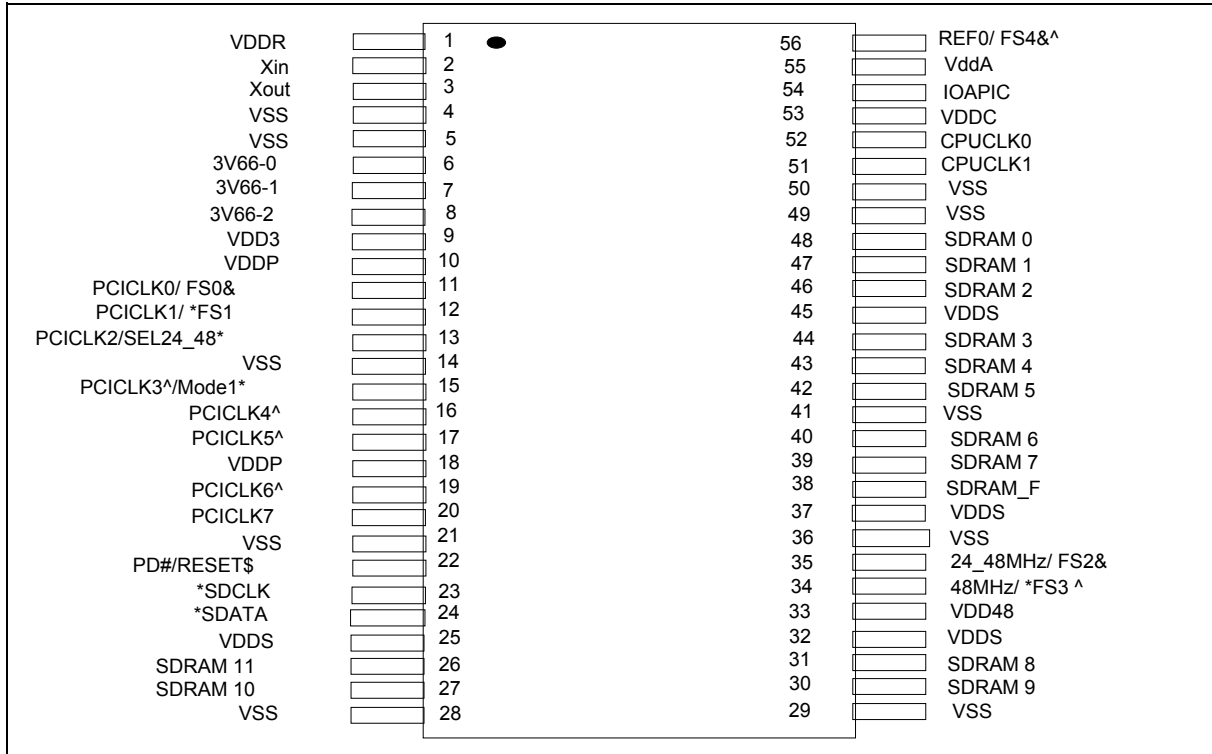

W83195BR-25/W83195BG-25



4. PIN DESCRIPTION

BUFFER TYPE SYMBOL	DESCRIPTION
IN	Input
OUT	Output
I/O	Bi-directional Pin
#	Active Low
&	Internal 120K Ω pull-down
*	Internal 120k Ω pull-up

4.1 Crystal I/O

PIN	PIN NAME	TYPE	DESCRIPTION
2	Xin	IN	Crystal input with internal loading capacitors (36pF) and feedback resistors.
3	Xout	OUT	Crystal output at 14.318MHz nominally with internal loading capacitors (36pF).

4.2 CPU, SDRAM, PCI, IOAPIC Clock Outputs

PIN	PIN NAME	TYPE	DESCRIPTION
52,51	CPUCLK [0:1]	OUT	Low skew (< 250ps) clock outputs for host frequencies such as CPU and Chipset.
22	PD#	IN	Mode1*=1, Power Down mode when driven low.
	RESET\$	OUT	Mode1*=0, RESET# open drain (4ms low active pulse when Watch Dog time out)
54	IOAPIC	OUT	Clock outputs synchronous with PCI clock and powered by VddA.
38,48,47,46,44,43,42,40,39,31,30,27,26	SDRAM_F, SDRAM [0:11]	OUT	SDRAM clock outputs.
11	PCICLK0	OUT	3.3V 33MHz PCI clock during normal operation.
	FS0&	IN	Latched input for FS0 at initial power up for H/W selecting the output frequency of CPU, SDRAM and PCI clocks (Default=0).
12	PCICLK1	OUT	Low skew (< 250ps) PCI clock outputs.
	*FS1	IN	Latched input for FS1 at initial power up for H/W selecting the output frequency of CPU, SDRAM and PCI clocks (Default=1).

W83195BR-25/W83195BG-25

winbond

200MHZ 3-DIMM CLOCK FOR SOLANO CHIPSET

CPU, SDRAM, PCI, IOAPIC Clock Outputs, continued

PIN	PIN NAME	TYPE	DESCRIPTION
13	PCICLK2	OUT	Low skew (< 250ps) PCI clock outputs.
	*SEL24_48	IN	Latched input for SEL24_48 at initial power up for the output frequency of 24MHz(HIGH) and 48MHz(LOW) clocks.
15	PCICLK3	OUT	Low skew (< 250ps) PCI clock outputs.
	Mode1*	IN	Latched input for Mode* pin at initial power up for the output PD# /RESET# output selection.
16,17,19,20	PCICLK [4:7]	OUT	Low skew (< 250ps) PCI clock outputs.
6,7,8	3V66 [0:2]	OUT	3.3V output clocks for the chipset.

4.3 I2C Control Interface

PIN	PIN NAME	TYPE	DESCRIPTION
24	*SDATA	I/O	Serial data of I ² C 2-wire control interface with internal pull-up resistor.
23	*SDCLK	IN	Serial clock of I ² C 2-wire control interface with internal pull-up resistor.

4.4 Fixed Frequency Outputs

PIN	PIN NAME	TYPE	DESCRIPTION
56	REF0	OUT	14.318MHz reference clock. This REF output is the stronger buffer for ISA bus loads.
	FS4&	IN	Latched input for FS4 at initial power up for H/W selecting the output frequency of CPU, SDRAM and PCI clocks (Default=0).
35	24_48MHz	OUT	24MHz or 48MHz output clock. Default is 24MHz.
	FS2&	IN	Latched input for FS2 at initial power up for H/W selecting the output frequency of CPU, SDRAM and PCI clocks (Default=0).
34	48MHz	OUT	48MHz output clock.
	FS3*	IN	Latched input for FS3 at initial power up for H/W selecting the output frequency of CPU, SDRAM and PCI clocks (Default=1).

W83195BR-25/W83195BG-25



4.5 Power Pins

PIN	PIN NAME	DESCRIPTION
53,55	VddC,VddA	Power supply for CPU & IOAPIC, 2.5V or 3.3V.
33	Vdd48	Power supply for 48MHz output,3.3V.
9	Vdd3	Power supply for 3V_66 output, 3.3V.
10,18	VddP	Power supply for PCICLK, 3.3V.
1	VddR	Power supply for REF0, 3.3V.
45,37,32,25	VddS	Power supply for SDRAM_F, SDRAM [0:11], nominal 3.3V.
4,5,14,21,28,29,36, 41, 49.50	Vss	Circuit Ground.

W83195BR-25/W83195BG-25



200MHZ 3-DIMM CLOCK FOR SOLANO CHIPSET

5. FREQUENCY SELECTION BY HARDWARE

FS4	FS3	FS2	FS1	FS0	CPU (MHz)	SDRAM (MHz)	3V66(MHz)	PCI (MHz)	IOAPIC (MHz)
0	0	0	0	0	55.00	82.50	55.00	27.50	13.75
0	0	0	0	1	60.00	90.00	60.00	30.00	15.00
0	0	0	1	0	66.80	100.20	66.80	33.40	16.70
0	0	0	1	1	68.33	102.50	68.33	34.17	17.08
0	0	1	0	0	70.00	105.00	70.00	35.00	17.50
0	0	1	0	1	72.00	108.00	72.00	36.00	18.00
0	0	1	1	0	75.00	112.50	75.00	37.50	18.75
0	0	1	1	1	77.00	115.50	77.00	38.50	19.25
0	1	0	0	0	83.30	83.30	55.53	27.77	13.88
0	1	0	0	1	90.00	90.00	60.00	30.00	15.00
0	1	0	1	0	100.30	100.30	66.87	33.43	16.72
0	1	0	1	1	103.00	103.00	68.67	34.33	17.17
0	1	1	0	0	112.50	112.50	75.00	37.50	18.75
0	1	1	0	1	115.00	115.00	76.67	38.33	19.17
0	1	1	1	0	120.00	120.00	80.00	40.00	20.00
0	1	1	1	1	125.00	125.00	83.33	41.67	20.83
1	0	0	0	0	128.00	128.00	64.00	32.00	16.00
1	0	0	0	1	130.00	130.00	65.00	32.50	16.25
1	0	0	1	0	133.70	133.70	66.85	33.43	16.71
1	0	0	1	1	137.00	137.00	68.50	34.25	17.13
1	0	1	0	0	140.00	140.00	70.00	35.00	17.50
1	0	1	0	1	145.00	145.00	72.50	36.25	18.13
1	0	1	1	0	150.00	150.00	75.00	37.50	18.75
1	0	1	1	1	153.33	153.33	76.67	38.33	19.17
1	1	0	0	0	125.00	93.75	62.50	31.25	15.63
1	1	0	0	1	130.00	97.50	65.00	32.50	16.25
1	1	0	1	0	133.70	100.28	66.85	33.43	16.71
1	1	0	1	1	137.00	102.75	68.50	34.25	17.13
1	1	1	0	0	140.00	105.00	70.00	35.00	17.50
1	1	1	0	1	145.00	108.75	72.50	36.25	18.13
1	1	1	1	0	150.00	112.50	75.00	37.50	18.75
1	1	1	1	1	153.33	115.00	76.67	38.33	19.17

W83195BR-25/W83195BG-25



6. SERIAL CONTROL REGISTERS

The Pin column lists the affected pin number and the @PowerUp column gives the state at true power up. Registers are set to the values shown only on true power up. "Command Code" byte and "Byte Count" byte must be sent following the acknowledge of the Address Byte. Although the data (bits) in these two bytes are considered "don't care", they must be sent and will be acknowledge. After that, the below described sequence (Register 0, Register 1, Register 2...) will be valid and acknowledged.

Frequency Table Setting by I2C (SEL5 ~ SEL0)

SSEL5	SSEL4	SSEL3	SSEL2	SSEL1	SSEL0	CPU (MHz)	SDRAM (MHz)	3V66 (MHz)	PCI (MHz)	IOAPIC (MHz)
0	0	0	0	0	0	55.00	82.50	55.00	27.50	13.75
0	0	0	0	0	1	60.00	90.00	60.00	30.00	15.00
0	0	0	0	1	0	66.80	100.20	66.80	33.40	16.70
0	0	0	0	1	1	68.33	102.50	68.33	34.17	17.08
0	0	0	1	0	0	70.00	105.00	70.00	35.00	17.50
0	0	0	1	0	1	72.00	108.00	72.00	36.00	18.00
0	0	0	1	1	0	75.00	112.50	75.00	37.50	18.75
0	0	0	1	1	1	77.00	115.50	77.00	38.50	19.25
0	0	1	0	0	0	83.30	83.30	55.53	27.77	13.88
0	0	1	0	0	1	90.00	90.00	60.00	30.00	15.00
0	0	1	0	1	0	100.30	100.30	66.87	33.43	16.72
0	0	1	0	1	1	103.00	103.00	68.67	34.33	17.17
0	0	1	1	0	0	112.50	112.50	75.00	37.50	18.75
0	0	1	1	0	1	115.00	115.00	76.67	38.33	19.17
0	0	1	1	1	0	120.00	120.00	80.00	40.00	20.00
0	0	1	1	1	1	125.00	125.00	83.33	41.67	20.83
0	1	0	0	0	0	128.00	128.00	64.00	32.00	16.00
0	1	0	0	0	1	130.00	130.00	65.00	32.50	16.25
0	1	0	0	1	0	133.70	133.70	66.85	33.43	16.71
0	1	0	0	1	1	137.00	137.00	68.50	34.25	17.13
0	1	0	1	0	0	140.00	140.00	70.00	35.00	17.50
0	1	0	1	0	1	145.00	145.00	72.50	36.25	18.13
0	1	0	1	1	0	150.00	150.00	75.00	37.50	18.75
0	1	0	1	1	1	153.33	153.33	76.67	38.33	19.17
0	1	1	0	0	0	125.00	93.75	62.50	31.25	15.63
0	1	1	0	0	1	130.00	97.50	65.00	32.50	16.25
0	1	1	0	1	0	133.70	100.28	66.85	33.43	16.71
0	1	1	0	1	1	137.00	102.75	68.50	34.25	17.13
0	1	1	1	0	0	140.00	105.00	70.00	35.00	17.50
0	1	1	1	0	1	145.00	108.75	72.50	36.25	18.13
0	1	1	1	1	0	150.00	112.50	75.00	37.50	18.75
0	1	1	1	1	1	153.33	115.00	76.67	38.33	19.17

W83195BR-25/W83195BG-25



SSEL5	SSEL4	SSEL3	SSEL2	SSEL1	SSEL0	CPU (MHz)	SDRAM (MHz)	3V66 (MHz)	PCI (MHz)	IOAPIC (MHz)
1	0	0	0	0	0	66.8	133.00	66.80	33.40	16.70
1	0	0	0	0	1	135.00	135.00	67.50	33.75	16.88
1	0	0	0	1	0	142.00	142.00	71.00	35.50	17.75
1	0	0	0	1	1	143.00	143.00	71.50	35.75	17.88
1	0	0	1	0	0	144.00	144.00	72.00	36.00	18.00
1	0	0	1	0	1	146.00	146.00	73.00	36.50	18.25
1	0	0	1	1	0	147.00	147.00	73.50	36.75	18.38
1	0	0	1	1	1	148.00	148.00	74.00	37.00	18.50
1	0	1	0	0	0	100.20	133.00	66.80	33.40	16.70
1	0	1	0	0	1	156.00	156.00	78.00	39.00	19.50
1	0	1	0	1	0	158.00	158.00	79.00	39.50	19.75
1	0	1	0	1	1	160.00	160.00	80.00	40.00	20.00
1	0	1	1	0	0	135.00	101.25	67.50	33.75	16.88
1	0	1	1	0	1	139.00	104.25	69.50	34.75	17.38
1	0	1	1	1	0	141.00	105.75	70.50	35.25	17.63
1	0	1	1	1	1	142.00	106.50	71.00	35.50	17.75
1	1	0	0	0	0	143.00	107.25	71.50	35.75	17.88
1	1	0	0	0	1	144.00	108.00	72.00	36.00	18.00
1	1	0	0	1	0	146.00	109.50	73.00	36.50	18.25
1	1	0	0	1	1	147.00	110.25	73.50	36.75	18.38
1	1	0	1	0	0	148.00	111.00	74.00	37.00	18.50
1	1	0	1	0	1	149.00	111.75	74.50	37.25	18.63
1	1	0	1	1	0	153.00	114.75	76.50	38.25	19.13
1	1	0	1	1	1	157.00	117.75	78.50	39.25	19.63
1	1	1	0	0	0	159.00	119.25	79.50	39.75	19.88
1	1	1	0	0	1	162.00	121.50	81.00	40.50	20.25
1	1	1	0	1	0	164.00	123.00	82.00	41.00	20.50
1	1	1	0	1	1	170.00	127.50	85.00	42.50	21.25
1	1	1	1	0	0	175.00	116.67	58.30	29.15	14.58
1	1	1	1	0	1	180.00	120.00	60.00	30.00	15.00
1	1	1	1	1	0	190.00	190.00	63.33	31.67	15.83
1	1	1	1	1	1	200.40	133.60	66.80	33.40	16.70

W83195BR-25/W83195BG-25



6.1 Register 0: CPU Frequency Select Register

BIT	@PowerUp	PIN	DESCRIPTION
7	0	-	SSEL3 (Frequency table selection by software via I ² C)
6	0	-	SSEL2 (Frequency table selection by software via I ² C)
5	0	-	SSEL1 (Frequency table selection by software via I ² C)
4	0	-	SSEL0 (Frequency table selection by software via I ² C)
3	0	-	0 = Selection by hardware 1 = Selection by software I ² C - Bit (2, 7:4)
2	0	-	SSEL4 (Frequency table selection by software via I ² C)
1	0	-	SSEL5 (Frequency table selection by software via I ² C)
0	0	-	0 = Running 1 = Tristate all outputs

6.2 Register 1: CPU Clock Register (1 = Active, 0 = Inactive)

BIT	@PowerUp	PIN	DESCRIPTION
7	X	-	FS0#
6	X	-	FS1#
5	X	-	FS2#
4	X	-	FS3#
3	X	-	FS4#
2	0	-	1 = ±0.25% Center type Spread Spectrum Modulation 0 = ±0.5% Center type Spread Spectrum Modulation
1	0	-	0 = Normal 1 = Spread Spectrum enabled
0	1	-	1 = Center type Spread Spectrum Modulation 0 = Down type Spread Spectrum Modulation

6.3 Register 2: SDRAM Clock Register (1 = Active, 0 = Inactive)

BIT	@PowerUp	PIN	DESCRIPTION
7	1	39	SDRAM7 (Active / Inactive)
6	1	40	SDRAM6 (Active / Inactive)
5	1	42	SDRAM5 (Active / Inactive)
4	1	43	SDRAM4 (Active / Inactive)
3	1	44	SDRAM3 (Active / Inactive)
2	1	46	SDRAM2 (Active / Inactive)
1	1	47	SDRAM1 (Active / Inactive)
0	1	48	SDRAM0 (Active / Inactive)

W83195BR-25/W83195BG-25



6.4 Register 3: PCI Clock Register (1 = Active, 0 = Inactive)

BIT	@PowerUp	PIN	DESCRIPTION
7	1	20	PCICLK7 (Active / Inactive)
6	1	19	PCICLK6 (Active / Inactive)
5	1	17	PCICLK5 (Active / Inactive)
4	1	16	PCICLK4 (Active / Inactive)
3	1	15	PCICLK3 (Active / Inactive)
2	1	13	PCICLK2 (Active / Inactive)
1	1	12	PCICLK1 (Active / Inactive)
0	1	11	PCICLK0 (Active / Inactive)

6.5 Register 4: Additional Register (1 = Active, 0 = Inactive)

BIT	@PowerUp	PIN	DESCRIPTION
7	1	8	3V66_2(Active / Inactive)
6	1	7	3V66_1(Active / Inactive)
5	1	6	3V66_0(Active / Inactive)
4	1	26	SDRAM11 (Active / Inactive)
3	1	27	SDRAM10 (Active / Inactive)
2	1	30	SDRAM9 (Active / Inactive)
1	1	31	SDRAM8 (Active / Inactive)
0	1	38	SDRAM_F (Active / Inactive)

6.6 Register 5: SDRAM Clock Register (1 = Active, 0 = Inactive)

BIT	@PowerUp	PIN	DESCRIPTION
7	1	-	CSkew2 (CPU to SDRAM skew program bit)
6	0	-	CSkew1 (CPU to SDRAM skew program bit)
5	0	-	CSkew0 (CPU to SDRAM skew program bit)
4	1	-	CASkew2 (CPU to 3V66 skew program bit)
3	0	-	CASkew1 (CPU to 3V66 skew program bit)
2	0	-	CASkew0 (CPU to 3V66 skew program bit)
1	1	51	CPUCLK1 (Active / Inactive)
0	1	52	CPUCLK0 (Active / Inactive)

W83195BR-25/W83195BG-25



6.7 Register 6 Watchdog Timer Register

BIT	@PowerUp	PIN	DESCRIPTION
7	0	-	Enable Count 1 = start timer 0 = stop timer
6	0	-	Second timeout status (READ ONLY)
5	0	-	Second count 5
4	0	-	Second count 4
3	0	-	Second count 3
2	0	-	Second count 2
1	0	-	Second count 1
0	0	-	Second count 0

6.8 Register 7: M/N Program Register

BIT	@PowerUp	PIN	DESCRIPTION
7	0	-	N value bit 8
6	0	-	Test 1(Please do not modify)
5	1	-	Test 0 (Please do not modify)
4	0	-	M value bit 4
3	0	-	M value bit 3
2	0	-	M value bit 2
1	0	-	M value bit 1
0	0	-	M value bit 0

6.9 Register 8: M/N Program Register

BIT	@PowerUp	PIN	DESCRIPTION
7	0	-	N value bit 7
6	0	-	N value bit 6
5	0	-	N value bit 5
4	0	-	N value bit 4
3	0	-	N value bit 3
2	0	-	N value bit 2
1	0	-	N value bit 1
0	0	-	N value bit 0

W83195BR-25/W83195BG-25



6.10 Register 9: Spread Spectrum Programming Register

BIT	@PowerUp	PIN	DESCRIPTION
7	0	-	Spread spectrum up count 3
6	0	-	Spread spectrum up count 2
5	0	-	Spread spectrum up count 1
4	0	-	Spread spectrum up count 0
3	0	-	Spread spectrum down count 3
2	0	-	Spread spectrum down count 2
1	0	-	Spread spectrum down count 1
0	0	-	Spread spectrum down count 0

6.11 Register 10: Divisor and Step-less Enable Register

BIT	@PowerUp	PIN	DESCRIPTION
7	0	-	0: use frequency table 1: use M/N register to program frequency The equation is VCO freq. = 14.318MHz * (N+4)/M
6	X	-	Ratio SEL3
5	X	-	Ratio SEL2
4	X	-	Ratio SEL1
3	X	-	Ratio SEL0
2	0	-	Reserved
1	0	-	Reserved
0	0	-	Reserved

REGISTER10 BIT3-6				RATIO		
BIT6	BIT 5	BIT 4	BIT 3	CPU	SDRAM	3V66
DS3	DS2	DS1	DS0			
0	0	0	0	4	4	6
0	0	0	1	3	3	6
0	0	1	0	2	3	6
0	0	1	1	2	2	6
0	1	0	0	6	4	6
0	1	0	1	3	4	6
0	1	1	0	6	3	6
0	1	1	1	4	3	6
1	0	x	x	2	2	4
1	1	x	x	2	4	6

W83195BR-25/W83195BG-25



6.12 Register 11: Winbond Chip ID Register (Read Only)

BIT	@PowerUp	PIN	DESCRIPTION
7	0	-	Winbond Chip ID
6	1	-	Winbond Chip ID
5	0	-	Winbond Chip ID
4	1	-	Winbond Chip ID
3	0	-	Winbond Chip ID
2	0	-	Winbond Chip ID
1	0	-	Winbond Chip ID
0	0	-	Winbond Chip ID

6.13 Register 12: Winbond Chip ID Register (Read Only)

BIT	@PowerUp	PIN	DESCRIPTION
7	0	-	Winbond Chip ID
6	0	-	Winbond Chip ID
5	0	-	Winbond Chip ID
4	1	-	Winbond Chip ID
3	0	-	Winbond Version ID
2	0	-	Winbond Version ID
1	1	-	Winbond Version ID
0	0	-	Winbond Version ID

W83195BR-25/W83195BG-25



7. SPECIFICATIONS

7.1 Absolute Maximum Ratings

Stresses greater than those listed in this table may cause permanent damage to the device. Precautions should be taken to avoid application of any voltage higher than the maximum rated voltages to this circuit. Maximum conditions for extended periods may affect reliability. Unused inputs must always be tied to an appropriate logic voltage level (Ground or Vdd).

SYMBOL	PARAMETER	RATING
Vdd , V _{IN}	Voltage on any pin with respect to GND	- 0.5 V to + 7.0 V
T _{STG}	Storage Temperature	- 65°C to + 150°C
T _B	Ambient Temperature	- 55°C to + 125°C
T _A	Operating Temperature	0°C to + 70°C

7.2 Electrical Characteristics---Input/Output

Vddq1=Vddq2 = Vddq3 = Vddq4 =3.3V, VddL1 =VddL2= 2.5V , T _A = 0°C to +70°C						
PARAMETER	SYMBOL	MIN	TYP	MAX	UNITS	TEST CONDITIONS
Input Low Voltage	V _{IL}	Vss-0.3		0.8	V _{dc}	
Input High Voltage	V _{IH}	2.0		Vdd+0.3	V _{dc}	
Input Low Current	I _{IL}	-5			μA	No pull-up resistors
Input Low Current	I _{IL}	-200			μA	Pull-up resistors
Input High Current	I _{IH}	-5		5	μA	
Input Capacitance	C _{IN}			5	pF	Logic inputs
	C _{OUT}			6	pF	Output capacitance
	C _{INX}	27		45	pF	Xin and Xout
Operating Supply Current	I _{dd3}			100	MA	CPU = 66.6 MHz PCI = 33.3 Mhz with load
Power Down Supply Current	I _{dd2}			600	μA	
Settling Time	T _s			3	mS	From first crossing to 1% target freq.
Delay	t _{PZH} , t _{PZH}	1		10	nS	Output enable delay
	t _{PLZ} , t _{PZH}	1		10	nS	Output enable delay

W83195BR-25/W83195BG-25



7.3 Electrical Characteristics of CPU Clock

V_{dd}=2.5V +/- 5%; C_L=10-20pF

PARAMETER	SYMBOL	MIN	TYP	MAX	UNITS	TEST CONDITIONS
Output Impedance	R _{DSP}	13.5		40	Ohm	
Output Impedance	R _{DSN}	13.5		40	Ohm	
Output Low Voltage	V _{OL}			0.4	V	I _{OL} =1mA
Output High Voltage	V _{OH}	2.0			V	I _{OH} =-1mA
Output Low Current	I _{OL}	27		30	MA	
Output High Current	I _{OH}	-27		-27	MA	
Pull-Up Current Min	I _{OH(min)}	-27			MA	V _{out} = 1.0 V
Pull-Up Current Max	I _{OH(max)}			-27	MA	V _{out} = 2.0V
Rise/Fall Time Min Between 0.4 V and 2.0 V	T _{RF(min)}	0.4			ns	10pF Load
Rise/Fall Time Max Between 0.4 V and 2.0 V	T _{RF(max)}			1.6	ns	20pF Load
Duty Cycle	Dt	45		55	%	V _T =1.25V
Skew	T _{SK}			175	ps	V _T =1.25V
Jitter	T _{sc-c}			250	ps	V _T =1.25V

7.4 Electrical Characteristics of 3V66 Clock

V_{dd}=3.3V +/- 5%; C_L=10-30pF

PARAMETER	SYMBOL	MIN	TYP	MAX	UNITS	TEST CONDITIONS
Output Impedance	R _{DSP}	15		55	Ohm	
Output Impedance	R _{DSN}	15		55	Ohm	
Output Low Voltage	V _{OL}			0.55	V	I _{OL} =1mA
Output High Voltage	V _{OH}	2.4			V	I _{OH} =-1mA
Output Low Current	I _{OL}	30		38	MA	
Output High Current	I _{OH}	-33		-33	MA	
Rise/Fall Time Min Between 0.4 V and 2.0 V	T _{RF(min)}	0.4			ns	10pF Load
Rise/Fall Time Max Between 0.4 V and 2.0 V	T _{RF(max)}			1.6	ns	20pF Load
Duty Cycle	Dt	45		55	%	V _T =1.5V
Skew	T _{SK}			175	ps	V _T =1.5V
Jitter	T _{sc-c}			500	ps	V _T =1.5V

W83195BR-25/W83195BG-25



7.5 Electrical Characteristics of SDRAM Clock

V_{dd}=3.3V +/- 5%; C_L=20-30pF

PARAMETER	SYMBOL	MIN	TYP	MAX	UNITS	TEST CONDITIONS
Output Impedance	R _{DSP}	13.5		40	Ohm	
Output Impedance	R _{DSN}	13.5		40	Ohm	
Output Low Voltage	V _{OL}			0.45	V	I _{OL} =1mA
Output High Voltage	V _{OH}	2.4			V	I _{OH} =-1mA
Output Low Current	I _{OL}	54		54	MA	
Output High Current	I _{OH}	-54		-45	MA	
Rise/Fall Time Min Between 0.4 V and 2.0 V	T _{RF(min)}	0.4			ns	10pF Load
Rise/Fall Time Max Between 0.4 V and 2.0 V	T _{RF(max)}			1.6	ns	20pF Load
Duty Cycle	Dt	45		55	%	V _T =1.5V
Skew	T _{SK}			250	ps	V _T =1.5V
Jitter	T _{SC-C}			250	ps	V _T =1.5V

7.6 Electrical Characteristics of PCI Clock

V_{dd}=3.3V +/- 5%; C_L=10-30pF

PARAMETER	SYMBOL	MIN	TYP	MAX	UNITS	TEST CONDITIONS
Output Impedance	R _{DSP}	15		55	Ohm	
Output Impedance	R _{DSN}	15		55	Ohm	
Output Low Voltage	V _{OL}			0.55	V	I _{OL} =1mA
Output High Voltage	V _{OH}	2.4			V	I _{OH} =-1mA
Output Low Current	I _{OL}	30		38	MA	
Output High Current	I _{OH}	-33		-33	MA	
Rise/Fall Time Min Between 0.4 V and 2.0 V	T _{RF(min)}	0.5			ns	10pF Load
Rise/Fall Time Max Between 0.4 V and 2.0 V	T _{RF(max)}			2.0	ns	20pF Load
Duty Cycle	Dt	45		55	%	V _T =1.5V
Skew	T _{SK}			500	ps	V _T =1.5V
Jitter	T _{SC-C}			500	ps	V _T =1.5V

W83195BR-25/W83195BG-25



7.7 Electrical Characteristics of 48MHz, REF Clock

V_{dd}=3.3V +/- 5%; C_L=10-20pF

PARAMETER	SYMBOL	MIN	TYP	MAX	UNITS	TEST CONDITIONS
Output Impedance	R _{DSP}	20		55	Ohm	
Output Impedance	R _{DSN}	20		55	Ohm	
Output Low Voltage	V _{OL}			0.4	V	I _{OL} =1mA
Output High Voltage	V _{OH}	2.4			V	I _{OH} =-1mA
Output Low Current	I _{OL}	29		27	MA	
Output High Current	I _{OH}	-29		-23	MA	
RiseTime	T _R		1.8	4	ns	10pF Load
Fall Time	T _F		1.7	4	ns	20pF Load
Duty Cycle	Dt	45		55	%	V _T =1.5V
Skew	T _{SK}			500	ps	V _T =1.5V
Jitter	T _{SC-C}			1000	ps	V _T =1.5V

W83195BR-25/W83195BG-25



8. ORDERING INFORMATION

PART NUMBER	PACKAGE TYPE	PRODUCTION FLOW
W83195BR-25	56 PIN SSOP	Commercial, 0°C to +70°C
W83195BG-25	56 PIN SSOP (Pb-free package)	Commercial, 0°C to +70°C

9. HOW TO READ THE TOP MARKING

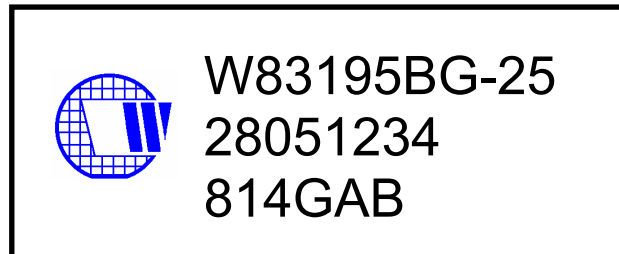
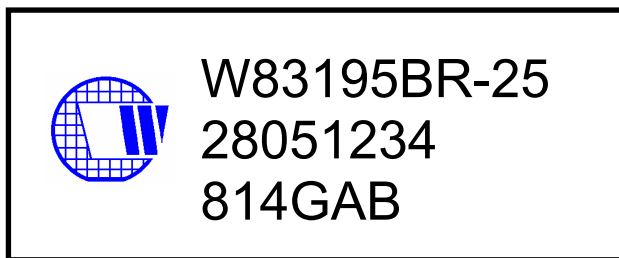

1st line: Winbond logo and the type number: W83195BR-25/W83195BG-25

2nd line: Tracking code 2 8051234

2: wafers manufactured in Winbond FAB 2

8051234: wafer production series lot number

3rd line: Tracking code 814 G A B

814: packages made in '98, week 14

G: assembly house ID; O means OSE, G means GR

A: Internal use code

B: IC revision

All the trademarks of products and companies mentioned in this data sheet belong to their respective owners.

W83195BR-25/W83195BG-25



200MHZ 3-DIMM CLOCK FOR SOLANO CHIPSET

10. PACKAGE DRAWING AND DIMENSIONS

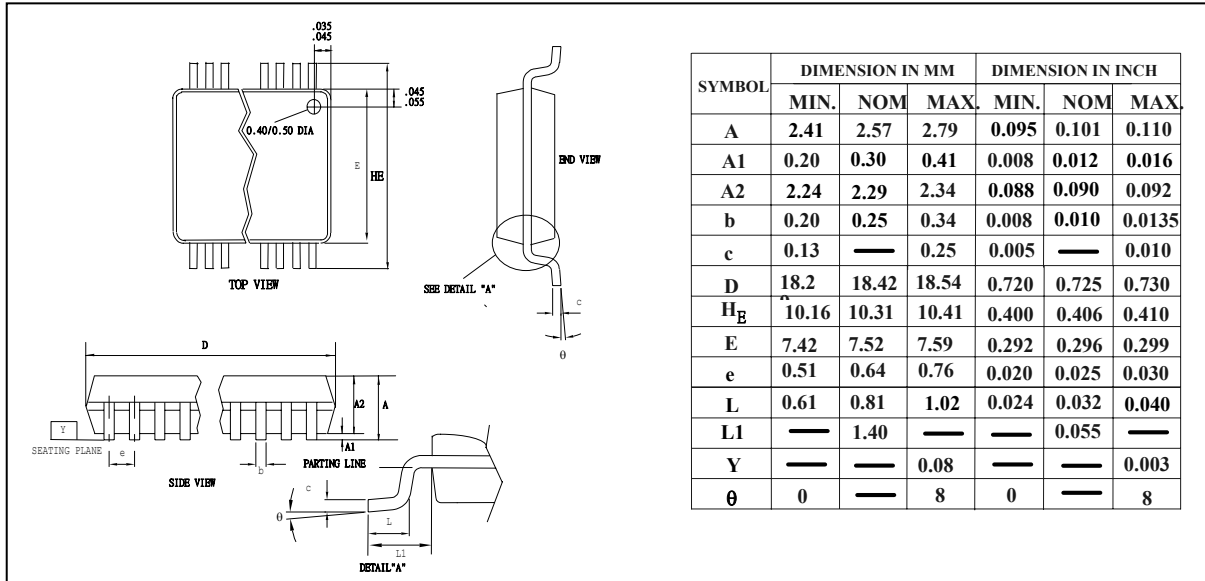

Please note that all data and specifications are subject to change without notice. All the trade marks of products and companies mentioned in this data sheet belong to their respective owners.

W83195BR-25/W83195BG-25



Important Notice

Winbond products are not designed, intended, authorized or warranted for use as components in systems or equipment intended for surgical implantation, atomic energy control instruments, airplane or spaceship instruments, transportation instruments, traffic signal instruments, combustion control instruments, or for other applications intended to support or sustain life. Further more, Winbond products are not intended for applications wherein failure of Winbond products could result or lead to a situation wherein personal injury, death or severe property or environmental damage could occur.

Winbond customers using or selling these products for use in such applications do so at their own risk and agree to fully indemnify Winbond for any damages resulting from such improper use or sales.

*Please note that all data and specifications are subject to change without notice.
All the trademarks of products and companies mentioned in this datasheet belong to their respective owners.*