

SN54ALS138, SN54AS138, SN74ALS138, SN74AS138 3-LINE TO 8-LINE DECODERS/DEMULTIPLEXERS

D2661, APRIL 1982 — REVISED MAY 1986

- Designed Specifically for High-Speed Memory Decoders and Data Transmission Systems
- Incorporates 3 Enable Inputs to Simplify Cascading and/or Data Reception
- Package Options Include Plastic "Small Outline" Packages, Ceramic Chip Carriers, and Standard Plastic and Ceramic 300-mil DIPs
- Dependable Texas Instruments Quality and Reliability

SN54ALS138, SN54AS138 . . . J PACKAGE
SN74ALS138, SN74AS138 . . . D OR N PACKAGE
(TOP VIEW)

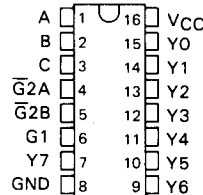

SN54ALS138, SN54AS138 . . . FK PACKAGE
(TOP VIEW)

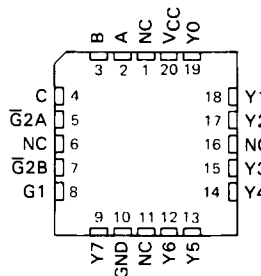

NC — No internal connection

description

The 'ALS138 and 'AS138 circuits are designed to be used in high-performance memory-decoding or data-routing applications requiring very short propagation delay times. In high-performance memory systems this decoder can be used to minimize the effects of system decoding. When employed with high-speed memories utilizing a fast enable circuit, the delay times of this decoder and the enable time of the memory are usually less than the typical access time of the memory. This means that the effective system delay introduced by the Schottky-clamped system decoder is negligible.

The conditions at the binary select inputs and the three enable inputs select one of eight input lines. Two active-low and one active-high enable inputs reduce the need for external gates or inverters when expanding. A 24-line decoder can be implemented without external inverters and a 32-line decoder requires only one inverter. An enable input can be used as a data input for demultiplexing applications.

The SN54ALS138 and SN54AS138 are characterized for operation over the full military temperature range of -55°C to 125°C . The SN74ALS138 and SN74AS138 are characterized for operation from 0°C to 70°C .

PRODUCTION DATA
This document contains information current as of publication date. Products conform to specifications per the terms of Texas Instruments standard warranty. Production processing does not necessarily include testing of all parameters.

**TEXAS
INSTRUMENTS**

POST OFFICE BOX 655012 • DALLAS, TEXAS 75265

Copyright © 1982, Texas Instruments Incorporated

SN54ALS138, SN54AS138, SN74ALS138, SN74AS138
3-LINE TO 8-LINE DECODERS/DEMULTIPLEXERS

logic symbols (alternatives) †

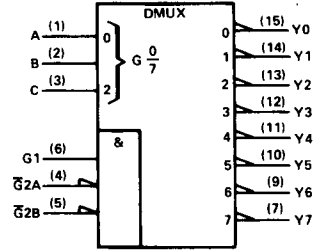
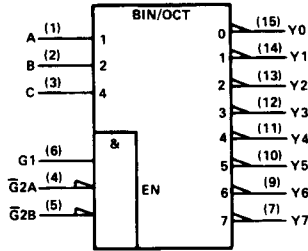

logic diagram (positive logic)

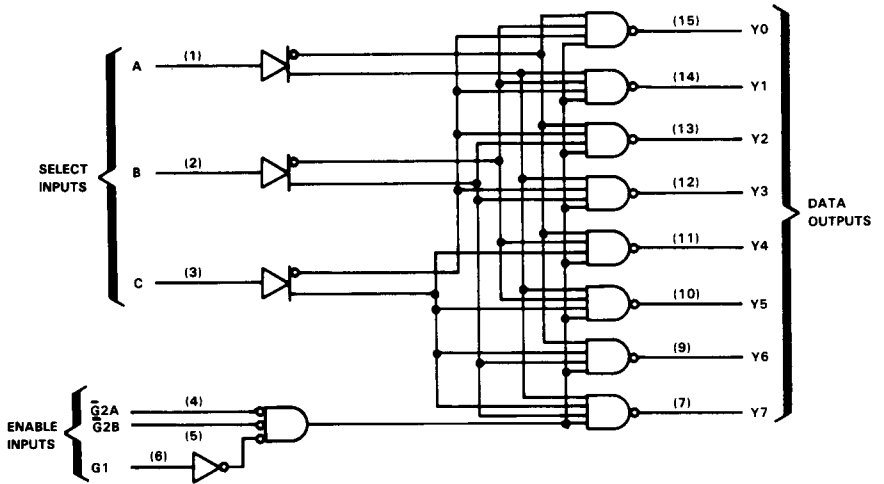

†These symbols are in accordance with ANSI/IEEE Std 91-1984 and IEC Publication 617-12. Pin numbers shown are for D, J, and N packages.

2

ALS and AS Circuits

SN54ALS138, SN54AS138, SN74ALS138, SN74AS138 3-LINE TO 8-LINE DECODERS/DEMULTIPLEXERS

FUNCTION TABLE

ENABLE INPUTS			SELECT INPUTS			OUTPUTS							
G1	G2A	G2B	C	B	A	Y0	Y1	Y2	Y3	Y4	Y5	Y6	Y7
X	H	X	X	X	X	H	H	H	H	H	H	H	H
X	X	H	X	X	X	H	H	H	H	H	H	H	H
L	X	X	X	X	X	H	H	H	H	H	H	H	H
H	L	L	L	L	L	L	H	H	H	H	H	H	H
H	L	L	L	L	H	H	L	H	H	H	H	H	H
H	L	L	L	H	L	H	H	L	H	H	H	H	H
H	L	L	L	H	H	H	H	L	H	H	H	H	H
H	L	L	H	L	L	H	H	H	H	L	H	H	H
H	L	L	H	H	L	H	H	H	H	H	L	H	H
H	L	L	H	H	H	H	H	H	H	H	H	L	H
H	L	L	H	H	H	H	H	H	H	H	H	H	L

absolute maximum ratings over operating free-air temperature range (unless otherwise noted)

Supply voltage, V_{CC}	7 V
Input voltage	7 V
Operating free-air temperature range; SN54ALS138, SN54AS138	-55°C to 125°C
SN74ALS138, SN74AS138	0°C to 70°C
Storage temperature range	-65°C to 150°C

recommended operating conditions

		SN54ALS138			SN74ALS138			UNIT
		MIN	NOM	MAX	MIN	NOM	MAX	
V_{CC}	Supply voltage	4.5	5	5.5	4.5	5	5.5	V
V_{IH}	High-level input voltage	2			2			V
V_{IL}	Low-level input voltage			0.7			0.8	V
I_{OH}	High-level output current			-0.4			-0.4	mA
I_{OL}	Low-level output current			4			8	mA
T_A	Operating free-air temperature	-55		125	0		70	°C

electrical characteristics over recommended operating free-air temperature range (unless otherwise noted)

PARAMETER	TEST CONDITIONS	SN54ALS138			SN74ALS138			UNIT
		MIN	TYP†	MAX	MIN	TYP†	MAX	
V_{IK}	$V_{CC} = 4.5$ V, $I_I = -18$ mA			-1.5			-1.5	V
V_{OH}	$V_{CC} = 4.5$ V to 5.5 V, $I_{OH} = -0.4$ mA	$V_{CC} - 2$			$V_{CC} - 2$			V
V_{OL}	$V_{CC} = 4.5$ V, $I_{OL} = 4$ mA		0.25	0.4		0.25	0.4	V
	$V_{CC} = 4.5$ V, $I_{OL} = 8$ mA					0.35	0.5	
I_I	$V_{CC} = 5.5$ V, $V_I = 7$ V			0.1			0.1	mA
I_{IH}	$V_{CC} = 5.5$ V, $V_I = 2.7$ V			20			20	μA
I_{IL}	$V_{CC} = 5.5$ V, $V_I = 0.4$ V			-0.1			-0.1	mA
I_O^\ddagger	$V_{CC} = 5.5$ V, $V_O = 2.25$ V		-30	-112		-30	-112	mA
I_{CC}	$V_{CC} = 5.5$ V			5		5	10	mA

† All typical values are at $V_{CC} = 5$ V, $T_A = 25^\circ\text{C}$.

‡ The output conditions have been chosen to produce a current that closely approximates one half of the true short-circuit output current, I_{OS} .

SN54ALS138, SN74ALS138
3-LINE TO 8-LINE DECODERS/DEMULTIPLEXERS

switching characteristics (see Note 1)

PARAMETER	FROM (INPUT)	TO (OUTPUT)	VCC = 4.5 V to 5.5 V, CL = 50 pF, RL = 500 Ω, TA = MIN to MAX				UNIT
			SN54ALS138		SN74ALS138		
			MIN	MAX	MIN	MAX	
tPLH	A, B, C	Any Y	2	28	6	22	ns
tPHL			6	22	6	18	
tPLH	Enable	Any Y	2	22	4	17	ns
tPHL			4	21	5	17	

NOTE 1: Load circuit and voltage waveforms are shown in Section 1.

2

ALS and AS Circuits

SN54AS138, SN74AS138 3-LINE TO 8-LINE DECODERS/DEMULTIPLEXERS

recommended operating conditions

		SN54AS138			SN74AS138			UNIT
		MIN	NOM	MAX	MIN	NOM	MAX	
V _{CC}	Supply voltage	4.5	5	5.5	4.5	5	5.5	V
V _{IH}	High-level input voltage	2			2			V
V _{IL}	Low-level input voltage				0.8			V
I _{OH}	High-level output current				-2			mA
I _{OL}	Low-level output current				20			mA
T _A	Operating free-air temperature	-55			125			°C

electrical characteristics over recommended operating free-air temperature range (unless otherwise noted)

PARAMETER	TEST CONDITIONS	SN54AS138			SN74AS138			UNIT
		MIN	TYP [†]	MAX	MIN	TYP [†]	MAX	
V _{IK}	V _{CC} = 4.5 V, I _I = -18 mA	-1.2			-1.2			V
V _{OH}	V _{CC} = 4.5 V to 5.5 V, I _{OH} = -2 mA	V _{CC} - 2			V _{CC} - 2			V
V _{OL}	V _{CC} = 4.5 V, I _{OL} = 20 mA	0.35		0.5	0.35		0.5	V
I _I	V _{CC} = 5.5 V, V _I = 7 V				0.1			mA
I _{IH}	V _{CC} = 5.5 V, V _I = 2.7 V				20			μA
I _{IL}	V _{CC} = 5.5 V, V _I = 0.4 V				-0.5			μA
I _O [‡]	V _{CC} = 5.5 V, V _O = 2.25 V	-30		-112	-30		-112	mA
I _{CCH}	V _{CC} = 5.5 V	12		17.5	12		17.5	mA
I _{CCL}	V _{CC} = 5.5 V	14		20	14		20	mA

[†]All typical values are at V_{CC} = 5 V, T_A = 25°C.

[‡]The output conditions have been chosen to produce a current that closely approximates one half of the true short-circuit output current, I_{OS}.

switching characteristics (see Note 1)

PARAMETER	FROM (INPUT)	TO (OUTPUT)	V _{CC} 4.5 V to 5.5 V, C _L = 50 pF, R _L = 500 Ω, T _A = MIN to MAX				UNIT
			SN54AS138		SN74AS138		
			MIN	MAX	MIN	MAX	
[†] PLH	A, B, C	Any Y	2	11	2	10	ns
[†] PHL			2	11	2	9.5	
[†] PLH	G1	Any Y	2	11.5	2	10	ns
[†] PHL			2	11	2	10	
[†] PLH	$\bar{G}2$	Any Y	2	9	2	7.5	
[†] PHL			2	10	2	8.5	

NOTE 1. Load circuit and voltage waveforms are shown in Section 1.