

300mA Low Dropout (LDO) Linear Regulator

■ Features

- Input voltage range is up to 7V
- Dropout voltage 400mV at 300mA output current
- Guaranteed 300mA output current.
- Internal $R_{ON} = 1.5\Omega$ PMOS draws no base current
- Low quiescent current 50 μ A
- Output voltage: 1.5V/1.8V/2.0V/2.5V/2.8V/3.0V/3.3V/3.5V; accuracy 2%
- Fast transient response
- Good load regulation
- Current limit and thermal shutdown protection
- Short circuit current fold-back
- 3 leads SOT89, TO92 and SOT23 packages

■ Applications

- Wireless Communication
- Battery Powered device
- CD-ROM, DVD, and LAN Card
- PC peripheral

■ Ordering Information

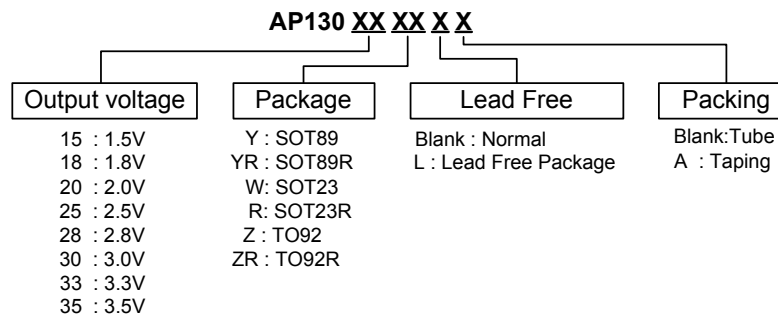

■ Block Diagram

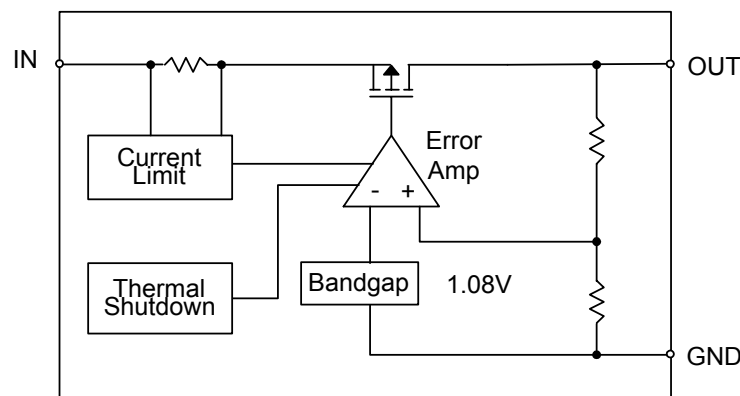

■ Pin Assignments and Pin Descriptions

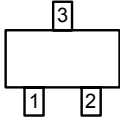
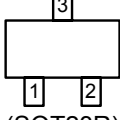
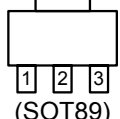
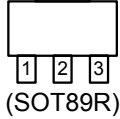
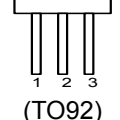
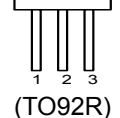
Package		No.	Name	Description
Type	Code			
(Top View)  (SOT23)	W	1	IN	IN: Power Input OUT: Output Voltage GND: Ground
		2	OUT	
		3	GND	
(Top View)  (SOT23R)	R	1	GND	
		2	OUT	
		3	IN	
(Top View)  (SOT89)	Y	1	OUT	
		2	GND	
		3	IN	
(Top View)  (SOT89R)	YR	1	GND	
		2	IN	
		3	OUT	
(Top View)  (TO92)	Z	1	IN	
		2	GND	
		3	OUT	
(Top View)  (TO92R)	ZR	1	GND	
		2	IN	
		3	OUT	



300mA Low Dropout (LDO) Linear Regulator

■ Absolute Maximum Ratings

Symbol	Parameter	Rating	Unit
V_{CC}	Input Voltage	-0.1 to +7	V
T_{OP}	Operating Junction Temperature Range	-40 to +125	°C
T_{ST}	Storage Temperature Range	-65 to +150	°C
P_D	Power Dissipation, P_D @ $T_A=25^\circ\text{C}$		
	TO-92	+0.6	W
	SOT-89	+0.5	W
	SOT-23	+0.25	W
θ_{JA}	Package Thermal Resistance		
	TO-92	+100	°C/W
	SOT-89	+100	°C/W
	SOT-23	+250	°C/W

■ Electrical Characteristics

$T_A=25^\circ\text{C}$, $C_{IN}=1\mu\text{F}$, $C_{OUT}=10\mu\text{F}$, unless otherwise specified.

Symbol	Parameter	Conditions	Min.	Typ.	Max.	Unit
V_{DROP}	Dropout Voltage (Note 1)	$I_L=300\text{mA}$	-	400	500	mV
I_{LIMIT}	Current Limit (Note 2)	$V_{IN}=5\text{V}$, $V_{OUT}=0\text{V}$	350	450	-	mA
I_{short}	Short Circuit Current	$V_{OUT}<1.05\text{V}$	-	150	300	mA
ΔV_{LINE}	Line Regulation	$I_L=1\text{mA}$, $V_{IN}=5\sim 7\text{V}$	-	0.1	0.3	%/V
PSRR	Ripple Rejection	$F=100\text{Hz}$, $C_{IN}=1\mu\text{F}$, $C_O=10\mu\text{F}$, $I_L=100\text{mA}$	-	58	-	dB
ΔV_{LOAD}	Load Regulation (Note 3)	$I_L=1\sim 300\text{mA}$, $V_{IN}=5\text{V}$	-	30	40	mV
ΔV_{OUT}	Output Voltage Accuracy	$I_L=1\text{mA}$, $V_{IN}=5\text{V}$	-2	-	+2	%
	Output Voltage Temperature Coefficient (Note 4)		-	50	150	PPM/°C
I_Q	Quiescent Current	$I_L=0\text{mA}$, $V_{IN}=5\text{V}$	-	50	100	μA

Note 1. Dropout voltage is defined as the input to output differential voltage. Dropout is measured at constant junction temperature by using pulsed ON time, and the criterion is V_{OUT} inside target value $\pm 2\%$. This test is skipped at the condition of $V_{IN}<3\text{V}$.

Note 2. Current limit is measured at constant junction temperature by using pulsed testing with a low ON time.

Note 3. Regulation is measured at constant junction temperature by using pulsed testing with a low ON time.

Note 4. Guaranteed by design.

■ Typical Characteristics

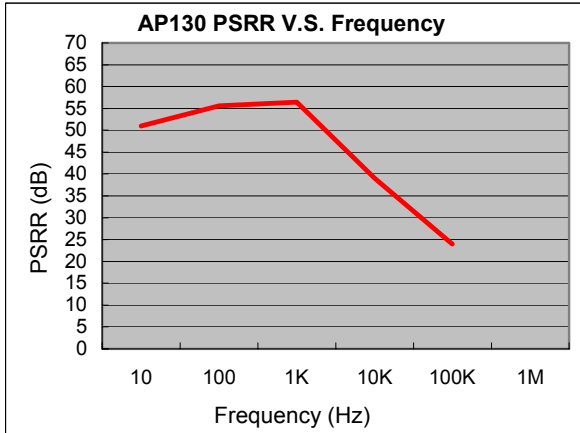

PSRR V.S. Frequency

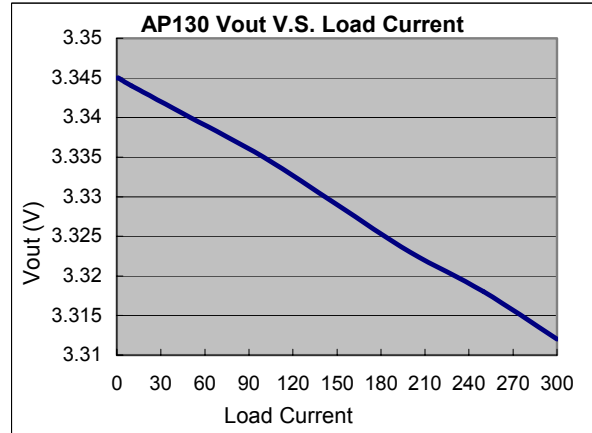

Vout V.S. Load Current

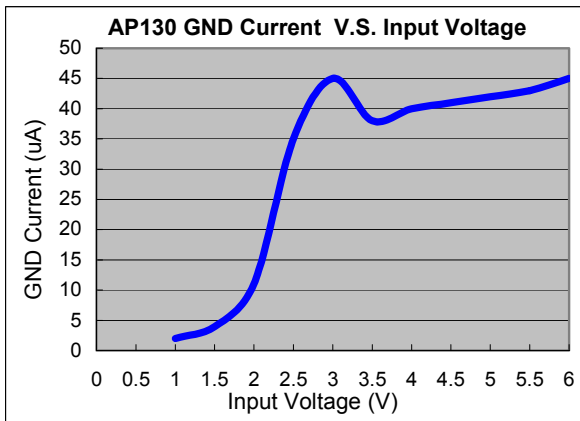

GND Current V.S. Input Voltage

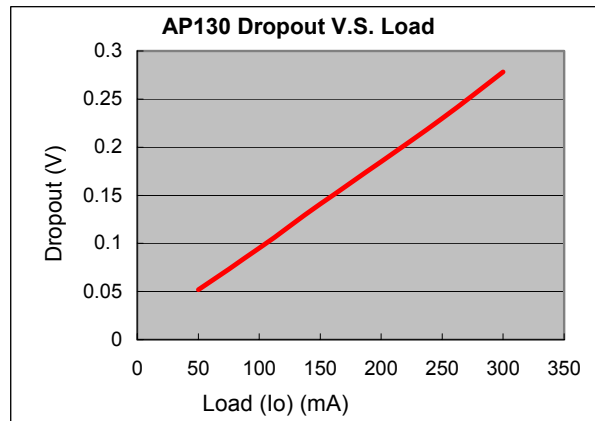

Dropout V.S. Load

■ Typical Application Circuit

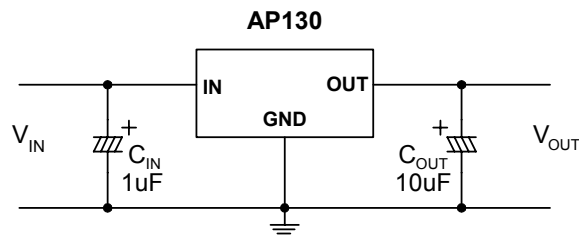

300mA Low Dropout (LDO) Linear Regulator

■ Function Description

A minimum of 10 μ F capacitor must be connected from OUT to ground to insure stability. Typically a large storage capacitor is connected from V_{IN} to ground to ensure that the input voltage does not sag below the minimum dropout voltage during the load transient response. This pin must always be 0.7V higher than V_{OUT} in order for the device to regulate properly.

■ Marking Information

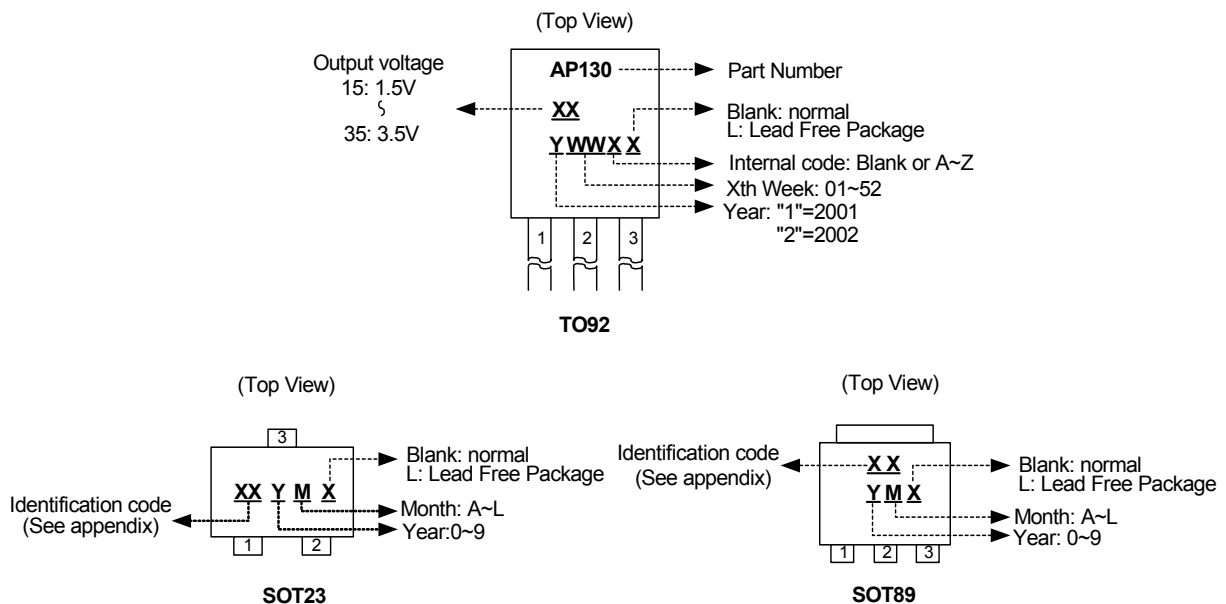

Appendix

Part Number		Identification code
SOT23	SOT89	
AP130-15W	AP130-15Y	CA
AP130-18W	AP130-18Y	CD
AP130-20W	AP130-20Y	CF
AP130-25W	AP130-25Y	CK
AP130-28W	AP130-28Y	CN
AP130-30W	AP130-30Y	CP
AP130-33W	AP130-33Y	CS
AP130-35W	AP130-35Y	CU

Part Number		Identification code
SOT23	SOT89	
AP130-15R	AP130-15YR	GO
AP130-18R	AP130-18YR	GR
AP130-20R	AP130-20YR	GT
AP130-25R	AP130-25YR	GY
AP130-28R	AP130-28YR	H1
AP130-30R	AP130-30YR	H3
AP130-33R	AP130-33YR	H9
AP130-35R	AP130-35YR	HB

■ Package Information

(1) Package Type: SOT89-3L

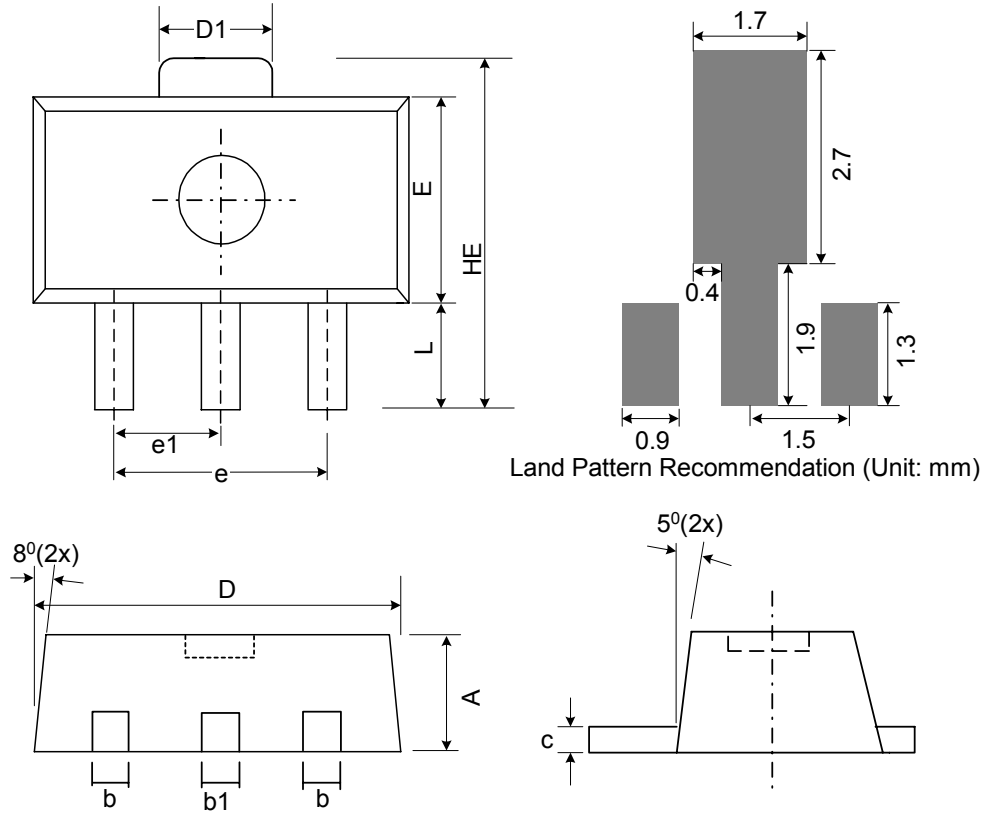

Symbol	Dimensions In Millimeters			Dimensions In Inches		
	Min.	Nom.	Max.	Min.	Nom.	Max.
A	1.40	1.50	1.60	0.055	0.059	0.063
b	0.36	0.42	0.48	0.014	0.016	0.018
b1	0.41	0.47	0.53	0.016	0.043	0.051
C	0.35	0.39	0.43	0.014	0.015	0.017
D	4.40	4.50	4.60	0.173	0.177	0.181
D1	1.40	1.60	1.75	0.055	0.062	0.069
e	2.90	3.00	3.10	0.114	0.118	0.122
e1	1.45	1.50	1.55	0.057	0.059	0.061
E	2.35	2.48	2.60	0.093	0.098	0.102
HE	3.94	-	4.25	0.155	-	0.167
L	0.80	-	1.20	0.031	-	0.047

■ Package Information (Continued)

(2) Package Type: SOT23-3L

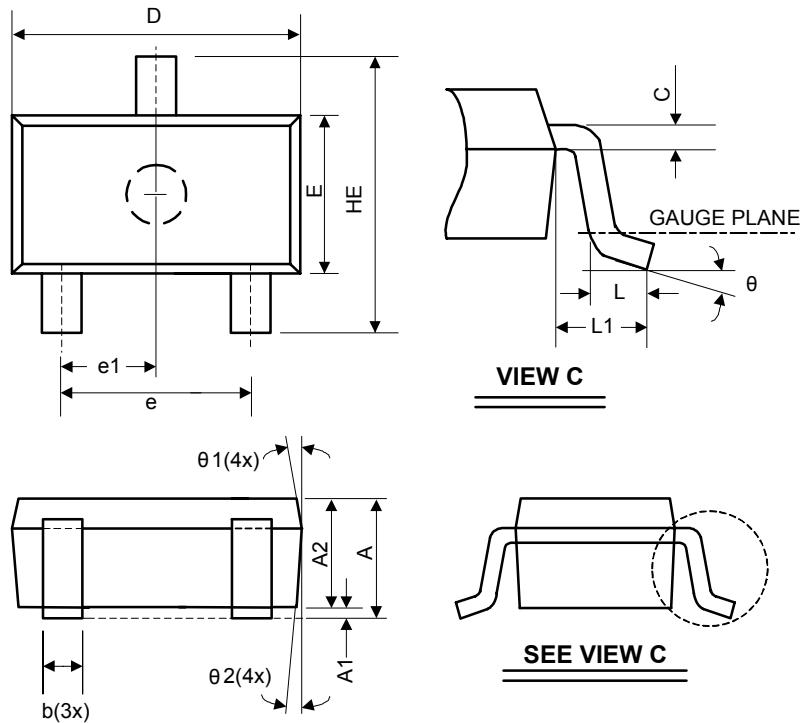

Symbol	Dimensions In Millimeters			Dimensions In Inches		
	Min.	Nom.	Max.	Min.	Nom.	Max.
A	1.05	-	1.35	0.041	-	0.053
A1	0.05	-	0.15	0.002	-	0.006
A2	1.00	1.10	1.20	0.039	0.043	0.047
b	0.25	-	0.50	0.010	-	0.020
C	0.08	-	0.20	0.003	-	0.008
D	2.70	2.90	3.00	0.106	0.114	0.118
E	1.50	1.60	1.70	0.059	0.063	0.067
HE	2.60	2.80	3.00	0.102	0.110	0.118
L	0.30	-	0.60	0.012	-	0.024
L1	0.50	0.60	0.70	0.020	0.024	0.028
e	1.80	1.90	2.00	0.071	0.075	0.079
e1	0.85	0.95	1.05	0.033	0.037	0.041
theta	0°	5°	10°	0°	5°	10°
theta1	3°	5°	7°	3°	5°	7°
theta2	6°	8°	10°	6°	8°	10°

■ Package Information (Continued)

(3) Package Type: TO92-3L

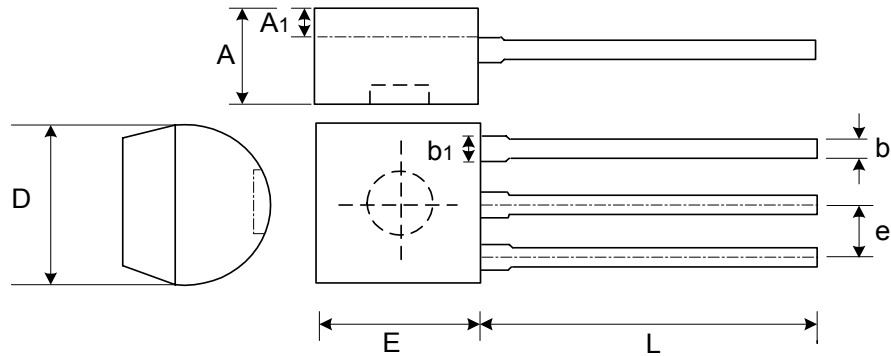

Symbol	Dimensions In Millimeters			Dimensions In Inches		
	Min.	Nom.	Max.	Min.	Nom.	Max.
A	3.302	3.556	3.810	0.130	0.140	0.150
A1	1.016	-	-	0.040	-	-
b	0.330	0.381	0.432	0.013	0.015	0.017
b1	0.406	0.457	0.506	0.016	0.018	0.020
D	4.445	4.572	4.699	0.175	0.180	0.185
E	4.445	4.572	4.699	0.175	0.180	0.185
L	13.00	-	15.500	0.512	-	0.610
e	1.150	1.270	1.390	0.045	0.050	0.055