



# 8044AH/8344AH/8744H HIGH PERFORMANCE 8-BIT MICROCONTROLLER WITH ON-CHIP SERIAL COMMUNICATION CONTROLLER

- 8044AH—Includes Factory Mask Programmable ROM
- 8344AH—For Use with External Program Memory
- 8744H—Includes User Programmable/Eraseable EPROM

## 8051 MICROCONTROLLER CORE

- Optimized for Real Time Control 12 MHz Clock, Priority Interrupts, 32 Programmable I/O Lines, Two 16-bit Timer/Counters
- Boolean Processor
- 4K × 8 ROM, 192 × 8 RAM
- 64K Accessible External Program Memory
- 64K Accessible External Data Memory
- 4 μs Multiply and Divide

## SERIAL INTERFACE UNIT (SIU)

- Serial Communication Processor that Operates Concurrently to CPU
- 2.4 Mbps Maximum Data Rate
- 375 Kbps using On-Chip Phase Locked Loop
- Communication Software in Silicon:
  - Complete Data Link Functions
  - Automatic Station Response
- Operates as an SDLC Primary or Secondary Station

The RUPI-44 family integrates a high performance 8-bit Microcontroller, the Intel 8051 Core, with an Intelligent/high performance HDLC/SDLC serial communication controller, called the Serial Interface Unit (SIU). See Figure 1. This dual architecture allows complex control and high speed data communication functions to be realized cost effectively.

Specifically, the 8044's Microcontroller features: 4K byte On-Chip program memory space; 32 I/O lines; two 16-bit timer/event counters; a 5-source; 2-level interrupt structure; a full duplex serial channel; a Boolean processor; and on-chip oscillator and clock circuitry. Standard TTL and most byte-oriented MCS-80 and MCS-85 peripherals can be used for I/O and memory expansion.

The Serial Interface Unit (SIU) manages the interface to a high speed serial link. The SIU offloads the On-Chip 8051 Microcontroller of communication tasks, thereby freeing the CPU to concentrate on real time control tasks.

The RUPI-44 family consists of the 8044, 8744, and 8344. All three devices are identical except in respect of on-chip program memory. The 8044 contains 4K bytes of mask-programmable ROM. User programmable EPROM replaces ROM in the 8744. The 8344 addresses all program memory externally.

The RUPI-44 devices are fabricated with Intel's reliable +5 volt, silicon-gate HMOSII technology and packaged in a 40-pin DIP.

The 8744H is available in a hermetically sealed, ceramic, 40-lead dual in-line package which includes a window that allows for EPROM erasure when exposed to ultraviolet light (See Erasure Characteristics). During normal operation, ambient light may adversely affect the functionality of the chip. Therefore applications which expose the 8744H to ambient light may require an opaque label over the window.

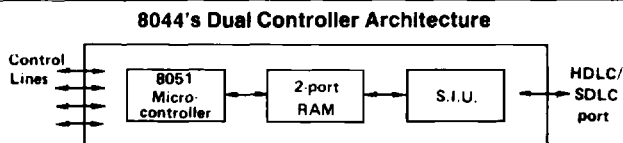

231663-1

Figure 1. Dual Controller Architecture

Table 1. RUPI-44 Family Pin Description

<p><b>VSS</b></p> <p>Circuit ground potential.</p>	<ul style="list-style-type: none"> <li>— DATA Tx/D (P3.1) In point-to-point or multipoint configurations, this pin functions as data input/output. In loop mode, it serves as transmit pin. A '0' written to this pin enables diagnostic mode.</li> </ul>
<p><b>VCC</b></p> <p>+5V power supply during operation and program verification.</p>	<ul style="list-style-type: none"> <li>— <math>\overline{\text{INT0}}</math> (P3.2). Interrupt 0 input or gate control input for counter 0.</li> <li>— <math>\overline{\text{INT1}}</math> (P3.3). Interrupt 1 input or gate control input for counter 1.</li> </ul>
<p><b>PORT 0</b></p> <p>Port 0 is an 8-bit open drain bidirectional I/O port. It is also the multiplexed low-order address and data bus when using external memory. It is used for data output during program verification. Port 0 can sink/source eight LS TTL loads (six in 8744).</p>	<ul style="list-style-type: none"> <li>— TO (P3.4). Input to counter 0.</li> <li>— SCLK T1 (P3.5). In addition to I/O, this pin provides input to counter 1 or serves as SCLK (serial clock) input.</li> <li>— <math>\overline{\text{WR}}</math> (P3.6). The write control signal latches the data byte from Port 0 into the External Data Memory.</li> <li>— <math>\overline{\text{RD}}</math> (P3.7). The read control signal enables External Data Memory to Port 0.</li> </ul>
<p><b>PORT 1</b></p> <p>Port 1 is an 8-bit quasi-bidirectional I/O port. It is used for the low-order address byte during program verification. Port 1 can sink/source four LS TTL loads.</p>	<p><b>RST</b></p> <p>A high on this pin for two machine cycles while the oscillator is running resets the device. A small external pulldown resistor (<math>\approx 8.2\text{K}\Omega</math>) from RST to <math>V_{\text{SS}}</math> permits power-on reset when a capacitor (<math>\approx 10\mu\text{f}</math>) is also connected from this pin to <math>V_{\text{CC}}</math>.</p>
<p>In non-loop mode two of the I/O lines serve alternate functions:</p> <ul style="list-style-type: none"> <li>— <math>\overline{\text{RTS}}</math> (P1.6). Request-to-Send output. A low indicates that the RUPI-44 is ready to transmit.</li> <li>— <math>\overline{\text{CTS}}</math> (P1.7). Clear-to-Send input. A low indicates that a receiving station is ready to receive.</li> </ul>	<p><b>ALE/<math>\overline{\text{PROG}}</math></b></p> <p>Provides Address Latch Enable output used for latching the address into external memory during normal operation. It is activated every six oscillator periods except during an external data memory access. It also receives the program pulse input for programming the EPROM version.</p>
<p><b>PORT 2</b></p> <p>Port 2 is an 8-bit quasi-bidirectional I/O port. It also emits the high-order address byte when accessing external memory. It is used for the high-order address and the control signals during program verification. Port 2 can sink/source four LS TTL loads.</p>	<p><b>PSEN</b></p> <p>The Program Store Enable output is a control signal that enables the external Program Memory to the bus during external fetch operations. It is activated every six oscillator periods, except during external data memory accesses. Remains high during internal program execution.</p>
<p><b>PORT 3</b></p> <p>Port 3 is an 8-bit quasi-bidirectional I/O port. It also contains the interrupt, timer, serial port and RD and WR pins that are used by various options. The output latch corresponding to a secondary function must be programmed to a one (1) for that function to operate. Port 3 can sink/source four LS LTT loads.</p>	<p><b><math>\overline{\text{EA}}</math>/<math>\overline{\text{VPP}}</math></b></p> <p>When held at a TTL high level, the RUPI-44 executes instructions from the internal ROM when the PC is less than 4096. When held at a TTL low level, the RUPI-44 fetches all instructions from external Program Memory. The pin also receives the 21V EPROM programming supply voltage on the 8744.</p>
<p>In addition to I/O, some of the pins also serve alternate functions as follows:</p> <ul style="list-style-type: none"> <li>— <math>\overline{\text{I/O}}</math> RxD (P3.0). In point-to-point or multipoint configurations, this pin controls the direction of pin P3.1. Serves as Receive Data input in loop and diagnostic modes.</li> </ul>	

Table 1. RUP1-44 Family Pin Description (Continued)

<p><b>XTAL 1</b></p> <p>Input to the oscillator's high gain amplifier. Required when a crystal is used. Connect to VSS when external source is used on XTAL 2.</p>	<p><b>XTAL 2</b></p> <p>Output from the oscillator's amplifier. Input to the internal timing circuitry. A crystal or external source can be used.</p>
--	---

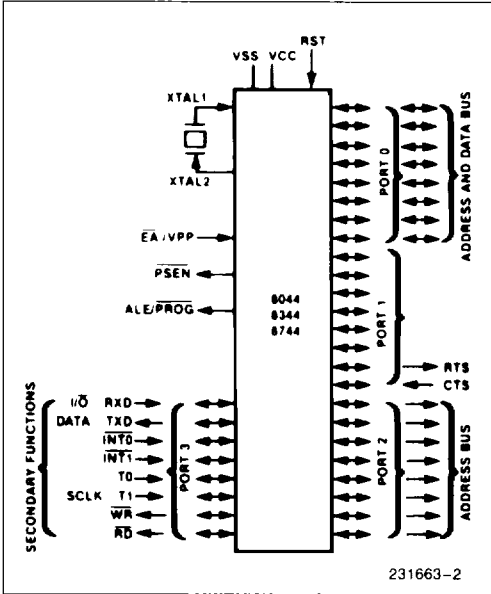

Figure 2. Logic Symbol

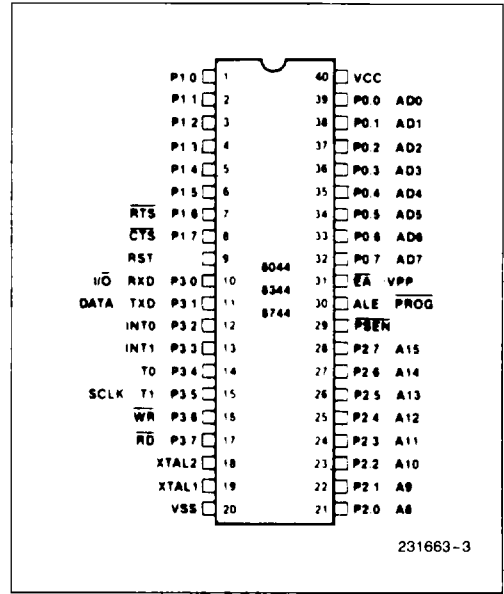

Figure 3A. DIP Pin Configuration

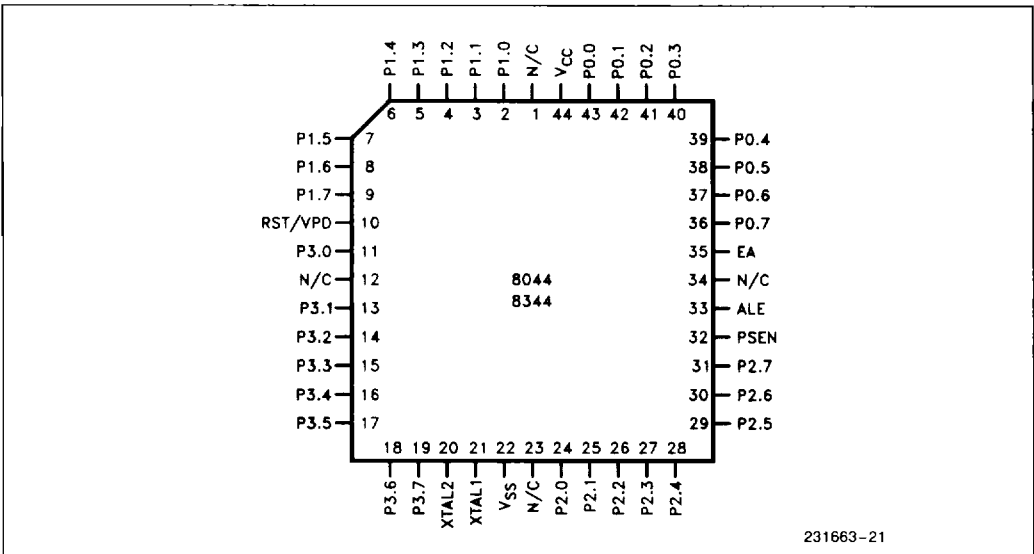

Figure 3B. PLCC Pin Configuration

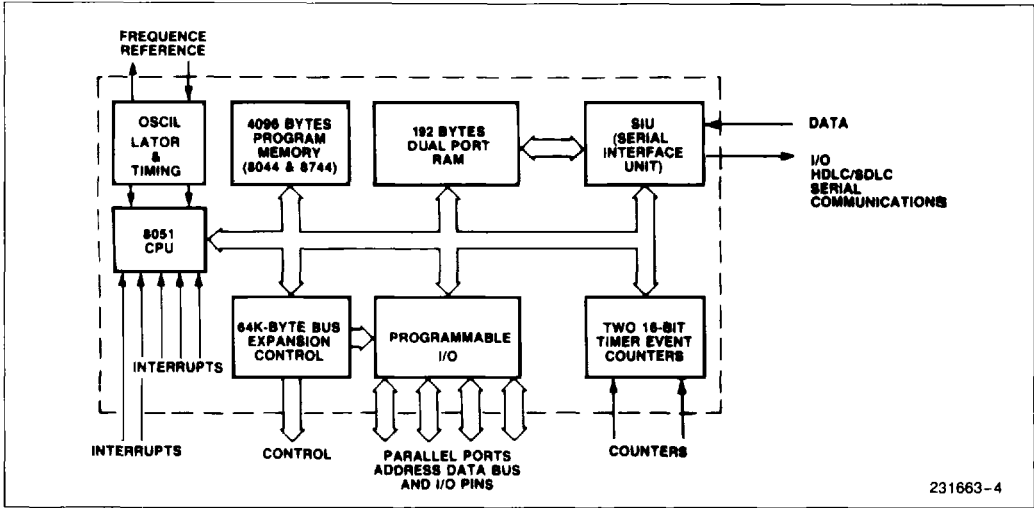

Figure 4. Block Diagram

**FUNCTIONAL DESCRIPTION**

**General**

The 8044 integrates the powerful 8051 microcontroller with an intelligent Serial Communication Controller to provide a single-chip solution which will efficiently implement a distributed processing or distributed control system. The microcontroller is a self-sufficient unit containing ROM, RAM, ALU, and its own peripherals. The 8044's architecture and instruction set are identical to the 8051's. The 8044 replaces the 8051's serial interface with an intelligent SDLC/HDLC Serial Interface Unit (SIU). 64 more bytes of RAM have been added to the 8051 RAM array. The SIU can communicate at bit rates up to 2.4 M bps. The SIU works concurrently with the Microcontroller so that there is no throughput loss in either unit. Since the SIU possesses its own intelligence, the CPU is off-loaded from many of the communications tasks, thus dedicating more of its computing power to controlling local peripherals or some external process.

- 4K bytes of ROM
- 192 bytes of RAM
- 32 I/O lines
- 64K address space for external Data Memory
- 64K address space for external Program Memory
- two fully programmable 16-bit timer/counters
- a five-source interrupt structure with two priority levels
- bit addressability for Boolean processing

**The Microcontroller**

The microcontroller is a stand-alone high-performance single-chip computer intended for use in sophisticated real-time application such as instrumentation, industrial control, and intelligent computer peripherals.

The major features of the microcontroller are:

- 8-bit CPU
- on-chip oscillator

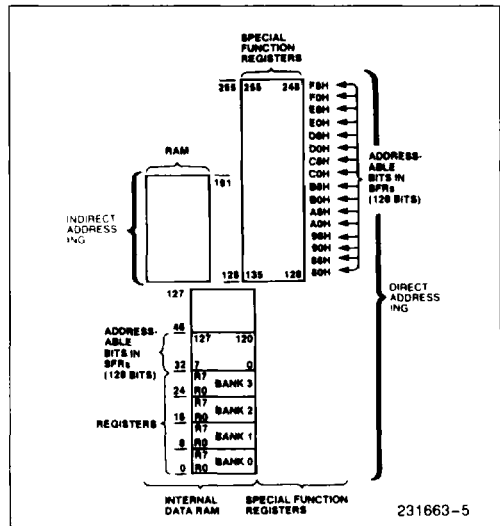

Figure 5. Internal Data Memory Address Space

- 1  $\mu$ s instruction cycle time for 60% of the instructions  
2  $\mu$ s instruction cycle time for 40% of the instructions
- 4  $\mu$ s cycle time for 8 by 8 bit unsigned Multiply/Divide

### INTERNAL DATA MEMORY

Functionally the Internal Data Memory is the most flexible of the address spaces. The Internal Data Memory space is subdivided into a 256-byte Internal Data RAM address space and a 128-bit Special Function Register address space as shown in Figure 5.

The Internal Data RAM address space is 0 to 255. Four 8-Register Banks occupy locations 0 through 31. The stack can be located anywhere in the Internal Data RAM address space. In addition, 128 bit locations of the on-chip RAM are accessible through Direct Addressing. These bits reside in Internal Data RAM at byte locations 32 through 47. Currently locations 0 through 191 of the Internal Data RAM address space are filled with on-chip RAM.

### Parallel I/O

The 8044 has 32 general-purpose I/O lines which are arranged into four groups of eight lines. Each group is called a port. Hence there are four ports; Port 0, Port 1, Port 2, and Port 3. Up to five lines from Port 3 are dedicated to supporting the serial channel when the SIU is invoked. Due to the nature of the serial port, two of Port 3's I/O lines (P3.0 and P3.1) do not have latched outputs. This is true whether or not the serial channel is used.

Port 0 and Port 2 also have an alternate dedicated function. When placed in the external access mode, Port 0 and Port 2 become the means by which the 8044 communicates with external program memory. Port 0 and Port 2 are also the means by which the 8044 communicates with external data memory. Peripherals can be memory mapped into the address space and controlled by the 8044.

Table 2. MCS<sup>®</sup>-51 Instruction Set Description

Mnemonic	Description	Byte	Cyc
<b>ARITHMETIC OPERATIONS</b>			
ADD A,Rn	Add register to Accumulator	1	1
ADD A,direct	Add direct byte to Accumulator	2	1
ADD A,@Ri	Add indirect RAM to Accumulator	1	1
ADD A,#data	Add immediate data to Accumulator	2	1
ADDC A,Rn	Add register to Accumulator with Carry	1	1
ADDC A,direct	Add direct byte to A with Carry flag	2	1
ADDC A,@Ri	Add indirect RAM to A with Carry flag	1	1
ADDC A,#data	Add immediate data to A with Carry flag	2	1
SUBB A,Rn	Subtract register from A with Borrow	1	1
SUBB A,direct	Subtract direct byte from A with Borrow	2	1

Mnemonic	Description	Byte	Cyc
<b>ARITHMETIC OPERATIONS (Continued)</b>			
SUBB A,@Ri	Subtract indirect RAM from A with Borrow	1	1
SUBB A,#data	Subtract immed data from A with Borrow	2	1
INC A	Increment Accumulator	1	1
INC Rn	Increment register	1	1
INC direct	Increment direct byte	2	1
INC @Ri	Increment indirect RAM	1	1
INC DPTR	Increment Data Pointer	1	2
DEC A	Decrement Accumulator	1	1
DEC Rn	Decrement register	1	1
DEC direct	Decrement direct byte	2	1
DEC @Ri	Decrement indirect RAM	1	1
MUL AB	Multiply A & B	1	4
DIV AB	Divide A by B	1	4
DA A	Decimal Adjust Accumulator	1	1

Table 2. MCS<sup>®</sup>-51 Instruction Set Description (Continued)

Mnemonic	Description	Byte	Cyc	Mnemonic	Description	Byte	Cyc
<b>LOGICAL OPERATIONS</b>				<b>LOGICAL OPERATIONS (Continued)</b>			
ANL A,Rn	AND register to Accumulator	1	1	RL A	Rotate Accumulator Left	1	1
ANL A,direct	AND direct byte to Accumulator	2	1	RLC A	Rotate A Left through the Carry flag	1	1
ANL A,@RI	AND indirect RAM to Accumulator	1	1	RR A	Rotate Accumulator Right	1	1
ANL A,#data	AND immediate data to Accumulator	2	1	RRC A	Rotate A Right through Carry flag	1	1
ANL direct,A	AND Accumulator to direct byte	2	1	SWAP A	Swap nibbles within the Accumulator	1	1
ANL direct,#data	AND immediate data to direct byte	3	2	<b>DATA TRANSFER</b>			
ORL A,Rn	OR register to Accumulator	1	1	MOV A,Rn	Move register to Accumulator	1	1
ORL A,direct	OR direct byte to Accumulator	2	1	MOV A,direct	Move direct byte to Accumulator	2	1
ORL A,@Ri	OR indirect RAM to Accumulator	1	1	MOV A,@RI	Move indirect RAM to Accumulator	1	1
ORL A,#data	OR immediate data to Accumulator	2	1	MOV A,#data	Move immediate data to Accumulator	2	1
ORL direct,A	OR Accumulator to direct byte	2	1	MOV Rn,A	Move Accumulator to register	1	1
ORL direct,#data	OR immediate data to direct byte	3	2	MOV Rn,direct	Move direct byte to register	2	2
XRL A,Rn	Exclusive-OR register to Accumulator	1	1	MOV Rn,#data	Move immediate data to register	2	1
XRL A,direct	Exclusive-OR direct byte to Accumulator	2	1	MOV direct,A	Move Accumulator to direct byte	2	1
XRL A,@RI	Exclusive-OR indirect RAM to A	1	1	MOV direct,Rn	Move register to direct byte	2	2
XRL A,#data	Exclusive-OR immediate data to A	2	1	MOV direct,direct	Move direct byte to direct	3	2
XRL direct,A	Exclusive-OR Accumulator to direct byte	2	1	MOV direct,@Ri	Move indirect RAM to direct byte	2	2
XRL direct,#data	Exclusive-OR immediate data to direct	3	2	MOV direct,#data	Move immediate data to direct byte	3	2
CLR A	Clear Accumulator	1	1	MOV @Ri,A	Move Accumulator to indirect RAM	1	1
CPL A	Complement Accumulator	1	1	MOV @Ri,direct	Move direct byte to indirect RAM	2	2

Table 2. MCS<sup>®</sup>-51 Instruction Set Description (Continued)

Mnemonic	Description	Byte	Cyc
<b>DATA TRANSFER (Continued)</b>			
MOV @Ri, #data	Move immediate data to indirect RAM	2	1
MOV DPTR, #data16	Load Data Pointer with a 16-bit constant	3	2
MOVCA, @A + DPTR	Move Code byte relative to DPTR to A	1	2
MOVCA, @A + PC	Move Code byte relative to PC to A	1	2
MOVXA, @Ri	Move External RAM (8-bit addr) to A	1	2
MOVXA, @DPTR	Move External RAM (16-bit addr) to A	1	2
MOVX @Ri, A	Move A to External RAM (8-bit addr)	1	2
MOVX @DPTR, A	Move A to External RAM (16-bit) addr	1	2
PUSH direct	Push direct byte onto stack	2	2
POP direct	Pop direct byte from stack	2	2
XCH A, Rn	Exchange register with Accumulator	1	1
XCH A, direct	Exchange direct byte with Accumulator	2	1
XCH A, @Ri	Exchange indirect RAM with A	1	1
XCHD A, @Ri	Exchange low-order Digit ind RAM w A	1	1
<b>BOOLEAN VARIABLE MANIPULATION</b>			
CLR C	Clear Carry flag	1	1
CLR bit	Clear direct bit	2	1
SETB C	Set Carry Flag	1	1
SETB bit	Set direct Bit	2	1
CPL C	Complement Carry Flag	1	1
CPL bit	Complement direct bit	2	1
ANL C, bit	AND direct bit to Carry flag	2	2

Mnemonic	Description	Byte	Cyc
<b>BOOLEAN VARIABLE MANIPULATION (Continued)</b>			
ANL C, /bit	AND complement of direct bit to Carry	2	2
ORL C, /bit	OR direct bit to Carry flag	2	2
ORL C, /bit	OR complement of direct bit to Carry	2	2
MOV C, /bit	Move direct bit to Carry flag	2	1
MOV bit, C	Move Carry flag to direct bit	2	2
<b>PROGRAM AND MACHINE CONTROL</b>			
ACALL addr11	Absolute Subroutine Call	2	2
LCALL addr16	Long Subroutine Call	3	2
RET	Return from subroutine	1	2
RETI	Return from interrupt	1	2
AJMP addr11	Absolute Jump	2	2
LJMP addr16	Long Jump	3	2
SJMP rel	Short Jump (relative addr)	2	2
JMP @A + DPTR	Jump indirect relative to the DPTR	1	2
JZ rel	Jump if Accumulator is Zero	2	2
JNZ rel	Jump if Accumulator is Not Zero	2	2
JC rel	Jump if Carry flag is set	2	2
JNC rel	Jump if No Carry flag	2	2
JB bit, rel	Jump if direct Bit set	3	2
JNB bit, rel	Jump if direct Bit Not set	3	2
JBC bit, rel	Jump if direct Bit is set & Clear bit	3	2
CJNE A, direct, rel	Compare direct to A & Jump if Not Equal	3	2
CJNE A, #data, rel	Comp, immed, to A & Jump if Not Equal	3	2

Table 2. MCS<sup>®</sup>-51 Instruction Set Description (Continued)

Mnemonic	Description	Byte	Cyc
<b>PROGRAM AND MACHINE CONTROL</b>			
(Continued)			
CJNE Rn, #data, rel	Comp, immed, to reg & Jump if Not Equal	3	2
CJNE @Ri, #data, rel	Comp, immed, to ind. & Jump if Not Equal	3	2
DJNZ Rn, rel	Decrement register & Jump if Not Zero	2	2
DJNZ direct, rel	Decrement direct & Jump if Not Zero	3	2
NOP	No operation	1	1
<b>Notes on data addressing modes:</b>			
Rn	— Working register R0-R7		
direct	— 128 internal RAM locations, any I/O port, control or status register		
@Ri	— Indirect internal RAM location addressed by register R0 or R1		

**Notes on data addressing modes:**

(Continued)

#data — 8-bit constant included in instruction  
#data16 — 16-bit constant included as bytes 2 & 3 of instruction

bit — 128 software flags, any I/O pin, control or status bit

**Notes on program addressing modes:**

addr16 — Destination address for LCALL &amp; LJMP may be anywhere within the 64-K program memory address space

Addr11 — Destination address for ACALL &amp; AJMP will be within the same 2-K page of program memory as the first byte of the following instruction

rel — SJMP and all conditional jumps include an 8-bit offset byte, Range is +127 -128 bytes relative to first byte of the following instruction

All mnemonic copyrighted© Intel Corporation 1979

## Timer/Counters

The 8044 contains two 16-bit counters which can be used for measuring time intervals, measuring pulse widths, counting events, generating precise periodic interrupt requests, and clocking the serial communications. Internally the Timers are clocked at 1/12 of the crystal frequency, which is the instruction cycle time. Externally the counters can run up to 500 KHz.

## Interrupt System

External events and the real-time driven on-chip peripherals require service by the CPU asynchronous to the execution of any particular section of code. To tie the asynchronous activities of these functions to normal program execution, a sophisticated multiple-source, two priority level, nested interrupt system is provided. Interrupt response latency ranges from 3  $\mu$ sec to 7  $\mu$ sec when using a 12 MHz clock.

All five interrupt sources can be mapped into one of the two priority levels. Each interrupt source can be enabled or disabled individually or the entire interrupt system can be enabled or disabled. The five interrupt sources are: Serial Interface Unit, Timer 1, Timer 2, and two external interrupts. The external interrupts can be either level or edge triggered.

## Serial Interface Unit (SIU)

The Serial Interface Unit is used for HDLC/SDLC communications. It handles Zero Bit Insertion/Deletion, Flags automatic access recognition, and a 16-bit cyclic redundancy check. In addition it implements in hardware a subset of the SDLC protocol certain applications it is advantageous to have the CPU control the reception or transmission of every single frame. For this reason the SIU has two modes of operation: "AUTO" and "FLEXIBLE" (or "NON-AUTO"). It is in the AUTO mode that the SIU responds to SDLC frames without CPU intervention; whereas, in the FLEXIBLE mode the reception or transmission of every single frame will be under CPU control.

There are three control registers and eight parameter registers that are used to operate the serial interface. These registers are shown in Figure 5 and Figure 6. The control register set the modes of operation and provide status information. The eight parameter registers buffer the station address, receive and transmit control bytes, and point to the on-chip transmit and receive buffers.

Data to be received or transmitted by the SIU must be buffered anywhere within the 192 bytes of on-chip RAM. Transmit and receive buffers are not allowed to "wrap around" in RAM; a "buffer end" is generated after address 191 is reached.





With the addition of only a few bytes of code, the 8044's frame size is not limited to the size of its internal RAM (192 bytes), but rather by the size of external buffer with no degradation of the RUPI's features (e.g. NRZI, zero bit insertion/deletion, address recognition, cyclic redundancy check). There is a special function register called SIUST whose contents dictates the operation of the SIU. At low data rates, one section of the SIU (the Byte Processor) performs no function during known intervals. For a given data rate, these intervals (stand-by mode) are fixed. The above characteristics make it possible to program the CPU to move data to/from external RAM and to force the SIU to perform some desired hardware tasks while transmission or reception is taking place. With these modifications, external RAM can be utilized as a transmit and received buffer instead of the internal RAM.

### AUTO Mode

In the AUTO mode the SIU implements in hardware a subset of the SDLC protocol such that it responds to many SDLC frames without CPU intervention. All AUTO mode responses to the primary station will conform to IBM's SDLC definition. The advantages of the AUTO mode are that less software is required to implement a secondary station, and the hardware generated response to polls is much faster than doing it in software. However, the Auto mode can not be used at a primary station.

To transmit in the AUTO mode the CPU must load the Transmit Information Buffer, Transmit Buffer Start register, Transmit Buffer Length register, and set the Transmit Buffer Full bit. The SIU automatically responds to a poll by transmitting an information frame with the P/F bit in the control field set. When the SIU receives a positive acknowledgement from the primary station, it automatically increments the Ns field in the NSNR register and interrupts the CPU. A negative acknowledgement would cause the SIU to retransmit the frame.

To receive in the AUTO mode, the CPU loads the Receive Buffer Start register, the Receive Buffer Length register, clears the Receive Buffer Protect bit, and sets the Receive Buffer Empty bit. If the SIU is polled in this state, and the TBF bit indicates that the Transmit Buffer is empty, an automatic RR response will be generated. When a valid information frame is received the SIU will automatically increment Nr in the NSNR register and interrupt the CPU.

While in the AUTO mode the SIU can recognize and respond to the following commands without CPU intervention: I (Information), RR (Receive Ready), RNR (Receive Not Ready), REJ (Reject), and UP (Unnumbered Poll). The SIU can generate the fol-

lowing responses without CPU intervention: I (Information), RR (Receive Ready), and RNR (Receive Not Ready).

When the Receive Buffer Empty bit (RBE) indicates that the Receive Buffer is empty, the receiver is enabled, and when the RBE bit indicates that the Receive Buffer is full, the receiver is disabled. Assuming that the Receiver Buffer is empty, the SIU will respond to a poll with an I frame if the Transmit Buffer is full. If the Transmit Buffer is empty, the SIU will respond to a poll with a RR command if the Receive Buffer Protect bit (RBP) is cleared, or an RNR command if RBP is set.

### FLEXIBLE (or NON-AUTO) Mode

In the FLEXIBLE mode all communications are under control of the CPU. It is the CPU's task to encode and decode control fields, manage acknowledgements, and adhere to the requirements of the HDLC/SDLC protocols. The 8044 can be used as a primary or a secondary station in this mode.

To receive a frame in the FLEXIBLE mode, the CPU must load the Receive Buffer Start register, the Receive Buffer Length register, clear the Receive Buffer Protect bit, and set the Receive Buffer Empty bit. If a valid opening flag is received and the address field matches the byte in the Station Address register or the address field contains a broadcast address, the 8044 loads the control field in the receive control byte register, and loads the I field in the receive buffer. If there is no CRC error, the SIU interrupts the CPU, indicating a frame has just been received. If there is a CRC error, no interrupt occurs. The Receive Field Length register provides the number of bytes that were received in the information field.

To transmit a frame, the CPU must load the transmit information buffer, the Transmit Buffer Start register, the Transmit Buffer Length register, the Transmit Control Byte, and set the TBF and the RTS bit. The SIU, unsolicited by an HDLC/SDLC frame, will transmit the entire information frame, and interrupt the CPU, indicating the completion of transmission. For supervisory frames or unnumbered frames, the transmit buffer length would be 0.

### CRC

The FCS register is initially set to all 1's prior to calculating the FCS field. The SIU will not interrupt the CPU if a CRC error occurs (in both AUTO and FLEXIBLE modes). The CRC error is cleared upon receiving of an opening flag.

### Frame Format Options

In addition to the standard SDLC frame format, the 8044 will support the frames displayed in Figure 7. The standard SDLC frame is shown at the top of this figure. For the remaining frames the information field will incorporate the control or address bytes and the frame check sequences; therefore these fields will

be stored in the Transmit and Receive buffers. For example, in the non-buffered mode the third byte is treated as the beginning of the information field. In the non-addressed mode, the information field begins after the opening flag. The mode bits to set the frame format options are found in the Serial Mode register and the Status register.

FRAME OPTION	NFCS	NB	AM <sup>1</sup>	FRAME FORMAT
<b>Standard SDLC NON-AUTO Mode</b>	0	0	0	F   A   C   I   FCS   F
<b>Standard SDLC AUTO Mode</b>	0	0	1	F   A   C   I   FCS   F
<b>Non-Buffered Mode NON-AUTO Mode</b>	0	1	1	F   A   I   FCS   F
<b>Non-Addressed Mode NON-AUTO Mode</b>	0	1	0	F   I   FCS   F
<b>No FCS Field NON-AUTO Mode</b>	1	0	0	F   A   C   I   F
<b>No FCS Field AUTO Mode</b>	1	0	1	F   A   C   I   F
<b>No FCS Field Non-Buffered Mode NON-AUTO Mode</b>	1	1	1	F   A   I   F
<b>No FCS Field Non-Addressed Mode NON-AUTO Mode</b>	1	1	0	F   I   F

**Mode Bits:**  
 AM — "AUTO" Mode/Addressed Mode  
 NB — Non-Buffered Mode  
 NFCS — No FCS Field Mode

**Key to Abbreviations:**  
 F = Flag (01111110)                      I = Information Field  
 A = Address Field                          FCS = Frame Check Sequence  
 C = Control Field

**Note 1:**  
 The AM bit function is controlled by the NB bit. When NB = 0, AM becomes AUTO mode select, when NB = 1, AM becomes Address mode select.

Figure 7. Frame Format Options

## Extended Addressing

To realize an extended control field or an extended address field using the HDLC protocol, the FLEXIBLE mode must be used. For an extended control field, the SIU is programmed to be in the non-buffered mode. The extended control field will be the first and second bytes in the Receive and Transmit Buffers. For extended addressing the SIU is placed in the non-addressed mode. In this mode the CPU must implement the address recognition for received frames. The addressing field will be the initial bytes in the Transmit and Receive buffers followed by the control field.

The SIU can transmit and receive only frames which are multiples of 8 bits. For frames received with other than 8-bit multiples, a CRC error will cause the SIU to reject the frame.

## SDLC Loop Networks

The SIU can be used in an SDLC loop as a secondary or primary station. When the SIU is placed in the Loop mode it receives the data on pin 10 and transmits the data one bit time delayed on pin 11. It can also recognize the Go ahead signal and change it into a flag when it is ready to transmit. As a secondary station the SIU can be used in the AUTO or FLEXIBLE modes. As a primary station the FLEXIBLE mode is used; however, additional hardware is required for generating the Go Ahead bit pattern. In the Loop mode the maximum data rate is 1 Mbps clocked or 375 Kbps self-clocked.

## SDLC Multidrop Networks

The SIU can be used in a SDLC non-loop configuration as a secondary or primary station. When the SIU is placed in the non-loop mode, data is received and transmitted on pin 11, and pin 10 drives a tri-state buffer. In non-loop mode, modem interface pins, RTS and CTS, become available.

## Data Clocking Options

The 8044's serial port can operate in an externally clocked or self clocked system. A clocked system provides to the 8044 a clock synchronization to the data. A self-clocked system uses the 8044's on-chip Digital Phase Locked Loop (DPLL) to recover the clock from the data, and clock this data into the Serial Receive Shift Register.

In this mode, a clock synchronized with the data is externally fed into the 8044. This clock may be generated from an External Phase Locked Loop, or possibly supplied along with the data. The 8044 can

transmit and receive data in this mode at rates up to 2.4 Mbps.

This self clocked mode allows data transfer without a common system data clock. An on-chip Digital Phase Locked Loop is employed to recover the data clock which is encoded in the data stream. The DPLL will converge to the nominal bit center within eight bit transitions, worst case. The DPLL requires a reference clock of either 16 times (16x) or 32 times (32x) the data rate. This reference clock may be externally applied or internally generated. When internally generated either the 8044's internal logic clock (crystal frequency divided by two) or the timer 1 overflow is used as the reference clock. Using the internal timer 1 clock the data rates can vary from 244 to 62.5 Kbps. Using the internal logic clock at a 16x sampling rate, receive data can either be 187.5 Kbps, or 375 Kbps. When the reference clock for the DPLL is externally applied the data rates can vary from 0 to 375 Kbps at a 16x sampling rate.

To aid in a Phase Locked Loop capture, the SIU has a NRZI (Non Return to Zero Inverted) data encoding and decoding option. Additionally the SIU has a pre-frame sync option that transmits two bytes of alternating 1's and 0's to ensure that the receive station DPLL will be synchronized with the data by the time it receives the opening flag.

## Control and Status Registers

There are three SIU Control and Status Registers:  
Serial Mode Register (SMD)  
Status/Command Register (STS)  
Send/Receive Count Register (NSNR)

The SMD, STS, and NSNR, registers are all cleared by system reset. This assures that the SIU will power up in an idle state (neither receiving nor transmitting).

These registers and their bit assignments are described below.

### SMD: Serial Mode Register (byte-addressable)

Bit 7: 6 5 4 3 2 1 0

SCM2	SCM1	SCM0	NRZI	LOOP	PFS	NB	NFCS
------	------	------	------	------	-----	----	------

The Serial Mode Register (Address C9H) selects the operational modes of the SIU. The 8044 CPU can both read and write SMD. The SIU can read SMD but cannot write to it. To prevent conflict between CPU and SIU access to SMD, the CPU should write SMD only when the Request To Send (RTS) and

Receive Buffer Empty (RBE) bits (in the STS register) are both false (0). Normally, SMD is accessed only during initialization.

The individual bits of the Serial Mode Register are as follows:

Bit #	Name	Description
SMD.0	NFCS	No FCS field in the SDLC frame.
SMD.1	NB	Non-Buffered mode. No control field in the SDLC frame.
SMD.2	PFS	Pre-Frame Sync mode. In this mode, the 8044 transmits two bytes before the first flag of a frame, for DPLL synchronization. If NRZI is enabled, 00H is sent; otherwise, 55H is sent. In either case, 16 preframe transitions are guaranteed.
SMD.3	LOOP	Loop configuration.
SMD.4	NRZI	NRZI coding option. If bit = 1, NRZI coding is used. If bit = 0, then it is straight binary (NRZ).
SMD.5	SCM0	Select Clock Mode—Bit 0
SMD.6	SCM1	Select Clock Mode—Bit 1
SMD.7	SCM2	Select Clock Mode—Bit 2

The SCM bits decode as follows:

SCM	Clock Mode	Data Rate (Bits/sec)*
2 1 0	<b>Clock Mode</b>	
0 0 0	Externally clocked	0-2.4M**
0 0 1	Reserved	
0 1 0	Self clocked, timer overflow	244-62.5K
0 1 1	Reserved	
1 0 0	Self clocked, external 16x	0-375K
1 0 1	Self clocked, external 32x	0-187.5K
1 1 0	Self clocked, internal fixed	375K
1 1 1	Self clocked, internal fixed	187.5K

**NOTES:**

\*Based on a 12 Mhz crystal frequency

\*\*0-1 M bps in loop configuration

**STS: Status/Command Register (bit-addressable)**

Bit:	7	6	5	4	3	2	1	0
	TBF	RBE	RTS	SI	BOV	OPB	AM	RBP

The Status/Command Register (Address C8H) provides operational control of the SIU by the 8044

CPU, and enables the SIU to post status information for the CPU's access. The SIU can read STS, and can alter certain bits, as indicated below. The CPU can both read and write STS asynchronously. However, 2-cycle instructions that access STS during both cycles ('JBC/B, REL' and 'MOV/B, C.') should not be used, since the SIU may write to STS between the two CPU accesses.

The individual bits of the Status/Command Register are as follows:

Bit #	Name	Description
STS.0	RBP	Receive Buffer Protect. Inhibits writing of data into the receive buffer. In AUTO mode, RBP forces an RNR response instead of an RR.
STS.1	AM	AUTO Mode/Addressed Mode. Selects AUTO mode where AUTO mode is allowed. If NB is true, (= 1), the AM bit selects the addressed mode. AM may be cleared by the SIU.
STS.2	OPB	Optional Poll Bit. Determines whether the SIU will generate an AUTO response to an optional poll (UP with P = 0). OPM may be set or cleared by the SIU.
STS.3	BOV	Receive Buffer Overrun. BOV may be set or cleared by the SIU.
STS.4	SI	SIU Interrupt. This is one of the five interrupt sources to the CPU. The vector location = 23H. SI may be set by the SIU. It should be cleared by the CPU before returning from an interrupt routine.
STS.5	RTS	Request To Send. Indicates that the 8044 is ready to transmit or is transmitting. RTS may be read or written by the CPU. RTS may be read by the SIU, and in AUTO mode may be written by the SIU.
STS.6	RBE	Receive Buffer Empty. RBE can be thought of as Receive Enable. RBE is set to one by the CPU when it is ready to receive a frame, or has just read the buffer, and to zero by the SIU when a frame has been received.
STS.7	TBF	Transmit Buffer Full. Written by the CPU to indicate that it has filled the transmit buffer. TBF may be cleared by the SIU.



**NSNR: Send/Receive Count Register (bit-addressable)**

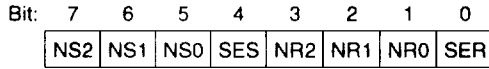

The Send/Receive Count Register (Address D8H) contains the transmit and receive sequence numbers, plus tally error indications. The SIU can both read and write NSNR. The 8044 CPU can both read and write NSNR asynchronously. However, 2-cycle instructions that access NSNR during both cycles ('JBC /B, REL,' and 'MOV /B,C') should not be used, since the SIU may write to NSMR between the two 8044 CPU accesses.

The individual bits of the Send/Receive Count Register are as follows:

Bit #	Name	Description
NSNR.0	SER	Receive Sequence Error: NS (P) ≠ NR (S)
NSNR.1	NR0	Receive Sequence Counter—Bit 0
NSNR.2	NR1	Receive Sequence Counter—Bit 1
NSNR.3	NR2	Receive Sequence Counter—Bit 2
NSNR.4	SES	Send Sequence Error: NR (P) ≠ NS (S) and NR (P) ≠ NS (S) + 1
NSNR.5	NS0	Send Sequence Counter—Bit 0
NSNR.6	NS1	Send Sequence Counter—Bit 1
NSNR.7	NS2	Send Sequence Counter—Bit 2

**Parameter Registers**

There are eight parameter registers that are used in connection with SIU operation. All eight registers may be read or written by the 8044 CPU. RFL and RCB are normally loaded by the SIU.

The eight parameter registers are as follows:

**STAD: Station Address Register (byte-addressable)**

The Station Address register (Address CEH) contains the station address. To prevent access conflict, the CPU should access STAD only when the SIU is idle (RTS = 0 and RBE = 0). Normally, STAD is accessed only during initialization.

**TBS: Transmit Buffer Start Address Register (byte-addressable)**

The Transmit Buffer Start address register (Address DCH) points to the location in on-chip RAM for the beginning of the I-field of the frame to be transmitted. The CPU should access TBS only when the SIU is not transmitting a frame (when TBF = 0).

**TBL: Transmit Buffer Length Register (byte = addressable)**

The Transmit Buffer Length register (Address DBH) contains the length (in bytes) of the I-field to be transmitted. A blank I-field (TBL = 0) is valid. The CPU should access TBL only when the SIU is not transmitting a frame (when TBF = 0).

**NOTE:**

The transmit and receive buffers are not allowed to "wrap around" in the on-chip RAM. A "buffer end" is automatically generated if address 191 (BFH) is reached.

**TCB: Transmit Control Byte Register (byte-addressable)**

The Transmit Control Byte register (Address DAH) contains the byte which is to be placed in the control field of the transmitted frame, during NON-AUTO mode transmission. The CPU should access TCB only when the SIU is not transmitting a frame (when TBF = 0). The NS and NR counters are not used in the NON-AUTO mode.

**RBS: Receive Buffer Start Address Register (byte-addressable)**

The Receive Buffer Start address register (Address CCH) points to the location in on-chip RAM where the beginning of the I-field of the frame being received is to be stored. The CPU should write RBS only when the SIU is not receiving a frame (when RBE = 0).

**RBL: Receive Buffer Length Register (byte-addressable)**

The Receive Buffer Length register (Address CBH) contains the length (in bytes) of the area in on-chip RAM allocated for the received I-field. RBL = 0 is valid. The CPU should write RBL only when RBE = 0.

**RFL: Receive Field Length Register  
(byte-addressable)**

The Receive Field Length register (Address CDH) contains the length (in bytes) of the received I-field that has just been loaded into on-chip RAM. RFL is loaded by the SIU. RFL = 0 is valid. RFL should be accessed by the CPU only when RBE = 0.

**RCB: Receive Control Byte Register  
(byte-addressable)**

The Received Control Byte register (Address CAH) contains the control field of the frame that has just been received. RCB is loaded by the SIU. The CPU can only read RCB, and should only access RCB when RBE = 0.

**ICE Support**

The 8044 In-Circuit Emulator (ICE-44) allows the user to exercise the 8044 application system and monitor the execution of instructions in real time.

The emulator operates with Intel's Intellec development system. The development system interfaces with the user's 8044 system through an in-cable buffer box. The cable terminates in a 8044 pin-compatible plug, which fits into the 8044 socket in the user's system. With the emulator plug in place, the user can exercise his system in real time while collecting up to 255 instruction cycles of real-time data. In addition, he can single-step the program.

Static RAM is available (in the in-cable buffer box) to emulate the 8044 internal and external program memory and external data memory. The designer can display and alter the contents of the replacement memory in the buffer box, the internal data memory, and the internal 8044 registers, including the SFR's.

**SIUST: SIU State Counter (byte-addressable)**

The SIU State Counter (Address D9H) reflects the state of the internal logic which is under SIU control. Therefore, care must be taken not to write into this register. This register provides a useful means for debugging 8044 receiver problem.

**ABSOLUTE MAXIMUM RATINGS\***

Ambient Temperature Under Bias ..... 0°C to 70°C  
 Storage Temperature..... -65°C to -150°C  
 Voltage on  $\overline{EA}$ , VPP Pin to VSS... -0.5V to -21.5V  
 Voltage on Any Other Pin to VSS.... -0.5V to -7V  
 Power Dissipation .....2W

NOTICE: This is a production data sheet. The specifications are subject to change without notice.

*\*WARNING: Stressing the device beyond the "Absolute Maximum Ratings" may cause permanent damage. These are stress ratings only. Operation beyond the "Operating Conditions" is not recommended and extended exposure beyond the "Operating Conditions" may affect device reliability.*

**D.C. CHARACTERISTICS**  $T_A = 0^\circ\text{C to } 70^\circ\text{C}$ ,  $V_{CC} = 5V \pm 10\%$ ,  $V_{SS} = 0V$

Symbol	Parameter	Min	Max	Unit	Test Conditions
VIL	Input Low Voltage (Except $\overline{EA}$ Pin of 8744H)	-0.5	0.8	V	
VIL1	Input Low Voltage to $\overline{EA}$ Pin of 8744H	0	0.8	V	
VIH	Input High Voltage (Except XTAL2, RST)	2.0	VCC + 0.5	V	
VIH1	Input High Voltage to XTAL2, RST	2.5	VCC + 0.5	V	XTAL1 = VSS
VOL	Output Low Voltage (Ports 1, 2, 3)*		0.45	V	IOL = 1.6mA
VOL1	Output Low Voltage (Port 0, ALE, $\overline{PSEN}$ )*				
		8744H	0.60 0.45	V V	IOL = 3.2 mA IOL = 2.4 mA
		8044AH/8344AH	0.45	V	IOL = 3.2 mA
VOH	Output High Voltage (Ports 1, 2, 3)	2.4		V	IOH = -80 $\mu\text{A}$
VOH1	Output High Voltage (Port 0 in External Bus Mode, ALE, $\overline{PSEN}$ )	2.4		V	IOH = -400 $\mu\text{A}$
IIL	Logical 0 Input Current (Ports 1, 2, 3)		-500	$\mu\text{A}$	Vin = 0.45V
IIL1	Logical 0 Input Current to $\overline{EA}$ Pin of 8744H only		-15	mA	
IIL2	Logical 0 Input Current (XTAL2)		-4.0	mA	Vin = 0.45V
ILI	Input Leakage Current (Port 0)				
	8744H	8044AH/8344AH	$\pm 100$ $\pm 10$	$\mu\text{A}$ $\mu\text{A}$	0.45 < Vin < VCC 0.45 < Vin < VCC
IIH	Logical 1 Input Current to $\overline{EA}$ Pin of 8744H		500	$\mu\text{A}$	
IIH1	Input Current to RST to Activate Reset		500	$\mu\text{A}$	Vin < (VCC - 1.5V)
ICC	Power Supply Current:				
	8744H	8044AH/8344AH	285 200	mA mA	All Outputs Disconnected: $\overline{EA} = V_{CC}$
CIO	Pin Capacitance		10	pF	Test Freq. = 1MHz <sup>(1)</sup>

**\*NOTES:**

1. Sampled not 100% tested.  $T_A = 25^\circ\text{C}$ .
2. Capacitive loading on Ports 0 and 2 may cause spurious noise pulses to be superimposed on the VOLs of ALE and Ports 1 and 3. The noise is due to external bus capacitance discharging into the Port 0 and Port 2 pin when these pins make 1-to-0 transitions during bus operations. In the worst cases (capacitive loading > 100 pF), the noise pulse on the ALE line may exceed 0.8V. In such cases it may be desirable to qualify ALE with a Schmitt Trigger, or use an address latch with a Schmitt Trigger STROBE input.



**A.C. CHARACTERISTICS**

$T_A = 0^\circ\text{C}$  to  $+70^\circ\text{C}$ ,  $V_{CC} = 5\text{V} \pm 10\%$ ,  $V_{SS} = 0\text{V}$ , Load Capacitance for Port 0, ALE, and PSEN = 100 pF, Load Capacitance for All Other Outputs = 80 pF

**EXTERNAL PROGRAM MEMORY CHARACTERISTICS**

Symbol	Parameter	12 MHz Osc		Variable Clock 1/TCLCL = 3.5 MHz to 12 MHz		Unit
		Min	Max	Min	Max	
TLHLL	ALE Pulse Width	127		2TCLCL-40		ns
TAVLL	Address Valid to ALE Low	43		TCLCL-40		ns
TLLAX <sup>1</sup>	Address Hold After ALE Low	48		TCLCL-35		ns
TLLIV	ALE Low to Valid Instr in 8744H 8044AH/8344AH		183 233		4TCLCL-150 4TCLCL-100	ns
TLLPL	ALE Low to $\overline{\text{PSEN}}$ Low	58		TCLCL-25		ns
TPLPH	$\overline{\text{PSEN}}$ Pulse Width 8744H 8044AH/8344AH	190 215		3TCLCL-60 3TCLCL-35		ns ns
TPLIV	$\overline{\text{PSEN}}$ Low to Valid Instr in 8744H 8044AH/8344AH		100 125		3TCLCL-150 3TCLCL-125	ns ns
TPXIX	Input Instr Hold After $\overline{\text{PSEN}}$	0		0		ns
TPXIZ <sup>2</sup>	Input Instr Float After $\overline{\text{PSEN}}$		63		TCLCL-20	ns
TPXAV <sup>2</sup>	$\overline{\text{PSEN}}$ to Address Valid	75		TCLCL-8		ns
TAVIV	Address to Valid Instr in 8744H 8044AH/8344AH		267 302		5TCLCL-150 5TCLCL-115	ns ns
TAZPL	Address Float to $\overline{\text{PSEN}}$	-25		-25		ns

**NOTES:**

- TLLAX for access to program memory is different from TLLAX for data memory.
- Interfacing RUP1-44 devices with float times up to 75ns is permissible. This limited bus contention will not cause any damage to Port 0 drivers.

## EXTERNAL DATA MEMORY CHARACTERISTICS

Symbol	Parameter	12 MHz Osc		Variable Clock 1/TCLCL = 3.5 MHz to 12 MHz		Unit
		Min	Max	Min	Max	
TRLRH	$\overline{RD}$ Pulse Width	400		6TCLCL-100		ns
TWLWH	$\overline{WR}$ Pulse Width	400		6TCLCL-100		ns
TLLAX	Address Hold after ALE	48		TCLCL-35		ns
TRLDV	$\overline{RD}$ Low to Valid Data in		252		5TCLCL-165	ns
TRHDX	Data Hold After $\overline{RD}$	0		0		ns
TRHDZ	Data Float After $\overline{RD}$		97		2TCLCL-70	ns
TLLDV	ALE Low to Valid Data In		517		8TCLCL-150	ns
TAVDV	Address to Valid Data In		585		9TCLCL-165	ns
TLLWL	ALE Low to $\overline{RD}$ or $\overline{WR}$ Low	200	300	3TCLCL-50	3TCLCL + 50	ns
TAVWL	Address to $\overline{RD}$ or $\overline{WR}$ Low	203		4TCLCL-130		ns
TQVWX	Data Valid to $\overline{WR}$ Transition					
	8744H	13		TCLCL-70		ns
	8044AH/8344AH	23		TCLCL-60		ns
TQVWH	Data Setup Before $\overline{WR}$ High	433		7TCLCL-150		ns
TWHQX	Data Held After $\overline{WR}$	33		TCLCL-50		ns
TRLAZ	$\overline{RD}$ Low to Address Float		25		25	ns
TWHLH	$\overline{RD}$ or $\overline{WR}$ High to ALE High					
	8744H	33	133	TCLCL-50	TCLCL + 50	ns
	8044AH/8344AH	43	123	TCLCL-40	TCLCL + 50	ns

## NOTE:

1. TLLAX for access to program memory is different from TLLAX for access data memory.

## Serial Interface Characteristics

Symbol	Parameter	Min	Max	Unit
TDCY	Data Clock	420		ns
TDCL	Data Clock Low	180		ns
TDCH	Data Clock High	100		ns
tTD	Transmit Data Delay		140	ns
tDSS	Data Setup Time	40		ns
tDHS	Data Hold Time	40		ns

WAVEFORMS

Memory Access

PROGRAM MEMORY READ CYCLE

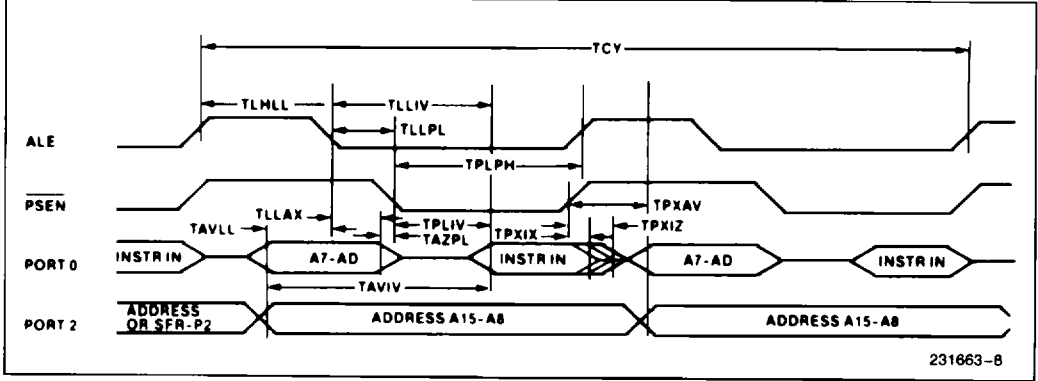

DATA MEMORY READ CYCLE

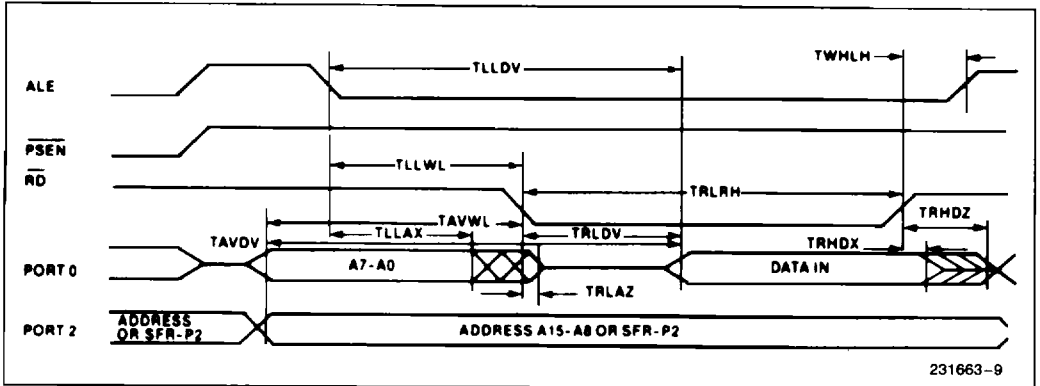

DATA MEMORY WRITE CYCLE

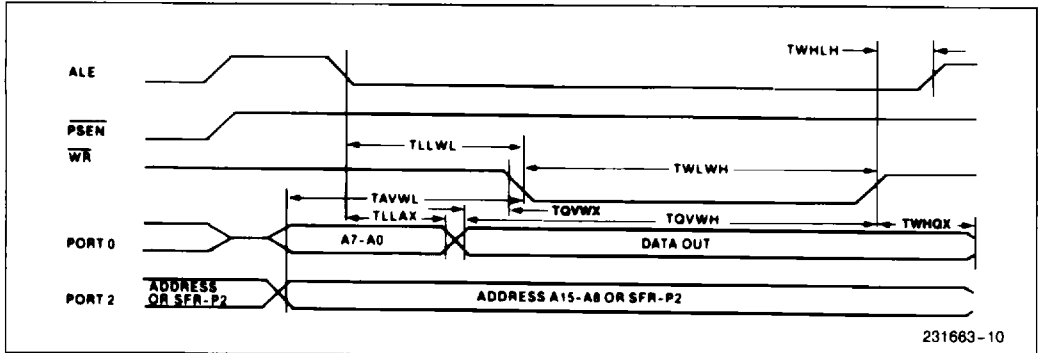

5

## SERIAL I/O WAVEFORMS

### SYNCHRONOUS DATA TRANSMISSION

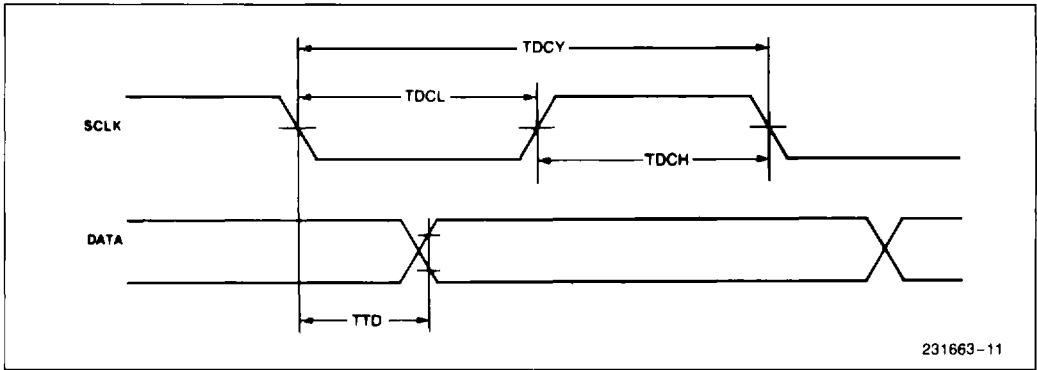

### SYNCHRONOUS DATA RECEPTION

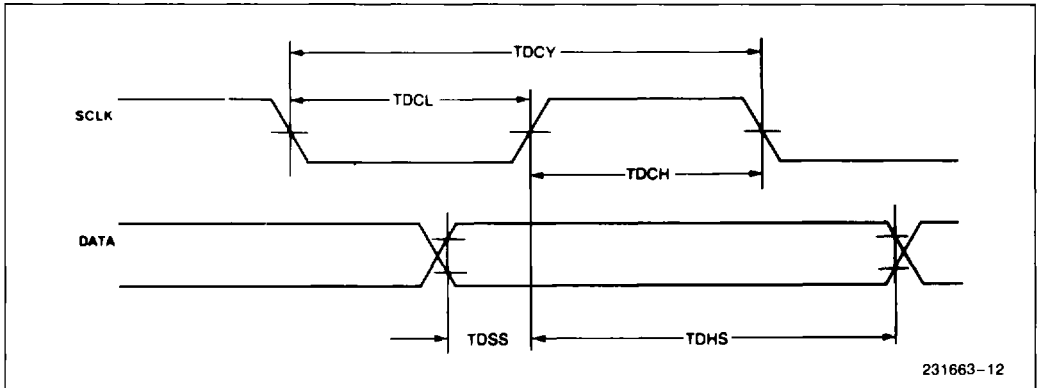

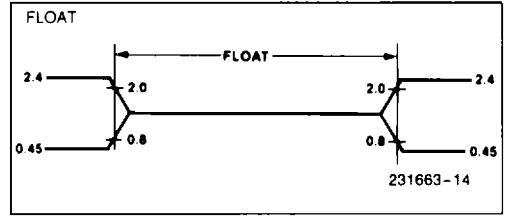
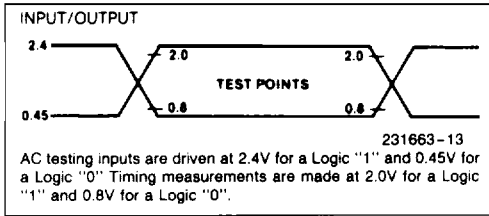
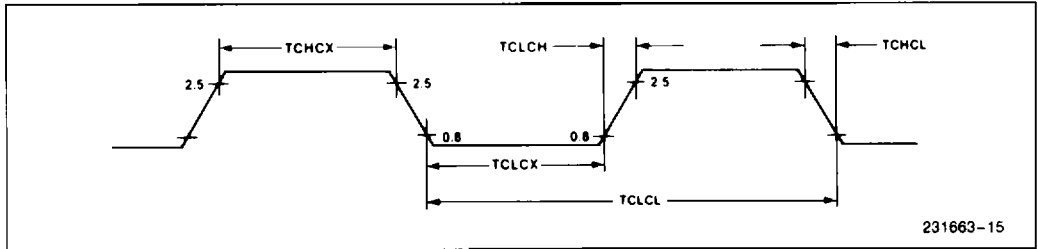
**AC TESTING INPUT, OUTPUT, FLOAT WAVEFORMS**

**EXTERNAL CLOCK DRIVE XTAL2**

Symbol	Parameter	Variable Clock Freq = 3.5 MHz to 12 MHz		Unit
		Min	Max	
TCLCL	Oscillator Period	83.3	285.7	ns
TCHCX	High Time	20	TCLCL-TCLCX	ns
TCLCX	Low Time	20	TCLCL-TCHCX	ns
TCLCH	Rise Time		20	ns
TCHCL	Fall Time		20	ns

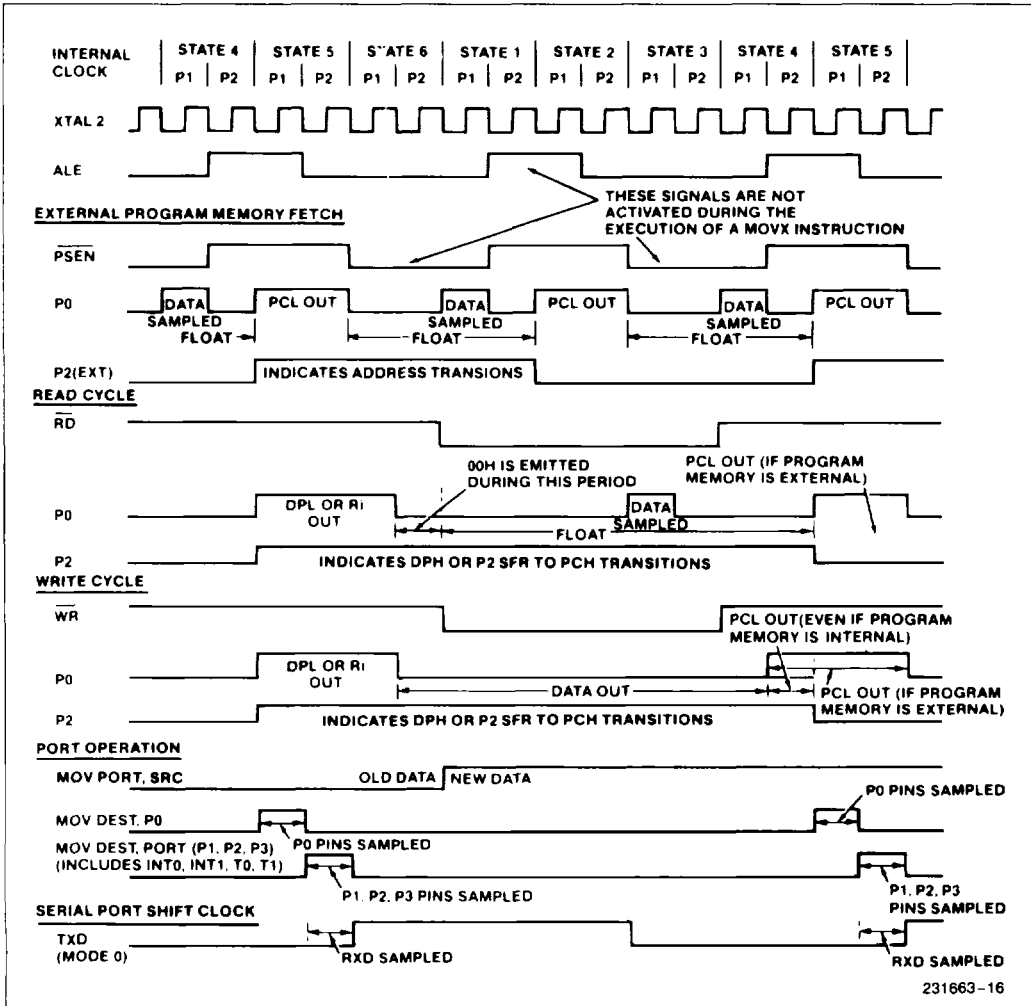
**CLOCK WAVEFORMS**



231663-16

This diagram indicates when signals are clocked internally. The time it takes the signals to propagate to the pins, however, ranges from 25 to 125 ns. This propagation delay is dependent on variables such as temperature and pin loading. Propagation also varies from output to output and component to component. Typically though, ( $T_A = 25^\circ\text{C}$ , fully loaded) RD and WR propagation delays are approximately 50 ns. The other signals are typically 85 ns. Propagation delays are incorporated in the AC specifications.

## 8744H EPROM CHARACTERISTICS

### Erase Characteristics

Erase of the 8744H Program Memory begins to occur when the chip is exposed to light with wavelengths shorter than approximately 4,000 Ångstroms. Since sunlight and fluorescent lighting have wavelengths in this range, constant exposure to these light sources over an extended period of time (about 1 week in sunlight, or 3 years in room-level fluorescent lighting) could cause unintentional erasure. If an application subjects the 8744H to this type of exposure, it is suggested that an opaque label be placed over the window.

The recommended erasure procedure is exposure to ultraviolet light (at 2537 Ångstroms) to an integrated dose of at least 15 W-sec/cm<sup>2</sup> rating for 20 to 30 minutes, at a distance of about 1 inch, should be sufficient.

Erase leaves the array in an all 1s state.

### Programming the EPROM

To be programmed, the 8744H must be running with a 4 to 6 MHz oscillator. (The reason the oscillator needs to be running is that the internal bus is being used to transfer address and program data to appropriate registers.) The address of an EPROM location to be programmed is applied to Port 1 and pins P2.0-P2.3 of Port 2, while the data byte is applied to Port 0. Pins P2.4-P2.6 and  $\overline{\text{PSEN}}$  should be held low, and P2.7 and RST high. (These are all TTL levels except RST, which requires 2.5V for high.)  $\overline{\text{EA}}/\text{VPP}$  is held normally high, and is pulsed to +21V. While EA/VPP is at 21V, the ALE/ $\overline{\text{PROG}}$  pin, which is normally being held high, is pulsed low for 50 msec. Then EA/VPP is returned to high. This is illustrated in Fig-

ure 8. Detailed timing specifications are provided in the EPROM Programming and Verification Characteristics section of this data sheet.

### Program Memory Security

The program memory security feature is developed around a "security bit" in the 8744H EPROM array. Once this "hidden bit" is programmed, electrical access to the contents of the entire program memory array becomes impossible. Activation of this feature is accomplished by programming the 8744H as described in "Programming the EPROM" with the exception that P2.6 is held at a TTL high rather than a TTL low. In addition, Port 1 and P2.0-P2.3 may be in any state. Figure 9 illustrates the security bit programming configuration. Deactivating the security feature, which again allows programmability of the EPROM, is accomplished by exposing the EPROM to ultraviolet light. This exposure, as described in "Erase Characteristics," erases the entire EPROM array. Therefore, attempted retrieval of "protected code" results in its destruction.

### Program Verification

Program Memory may be read only when the "security feature" has not been activated. Refer to Figure 10 for Program Verification setup. To read the Program Memory, the following procedure can be used. The unit must be running with a 4 to 6 MHz oscillator. The address of a Program Memory location to be read is applied to Port 1 and pins P2.0-P2.3 of Port 2. Pins P2.4-P2.6 and  $\overline{\text{PSEN}}$  are held at TTL low, while the ALE/ $\overline{\text{PROG}}$ , RST, and  $\overline{\text{EA}}/\text{VPP}$  pins are held at TTL high. (These are all TTL levels except RST, which requires 2.5V for high.) Port 0 will be the data output lines. P2.7 can be used as a read strobe. While P2.7 is held high, the Port 0 pins float. When P2.7 is strobed low, the contents of the addressed location will appear at Port 0. External pull-ups (e.g., 10K) are required on Port 0 during program verification.

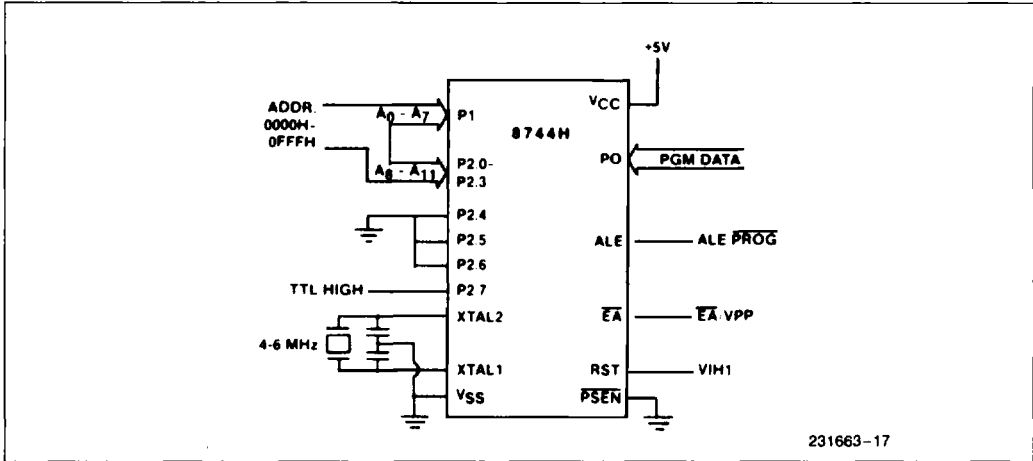

Figure 8. Programming Configuration

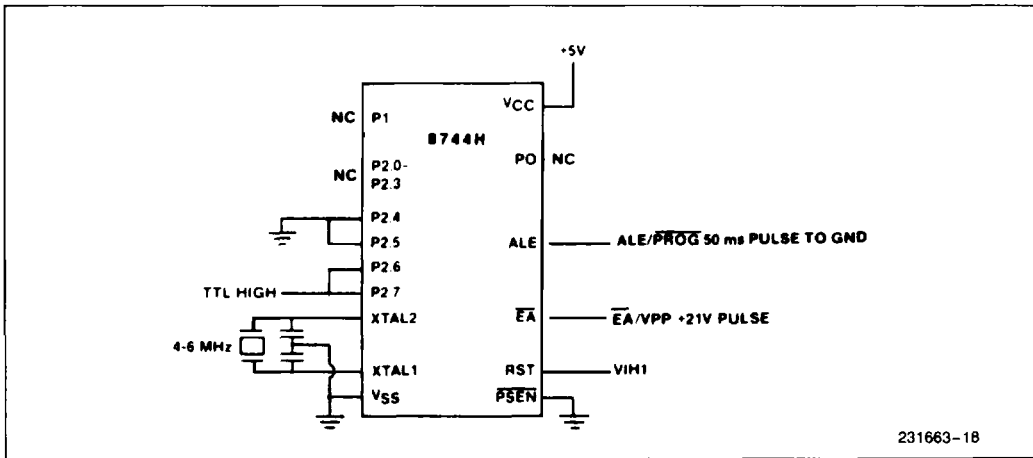

Figure 9. Security Bit Programming Configuration



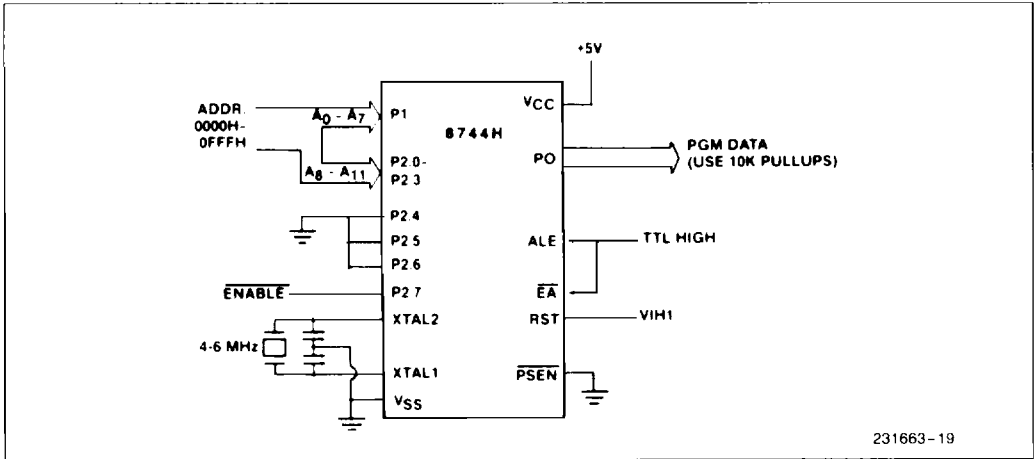

Figure 10. Program Verification Configuration

**EPROM PROGRAMMING, SECURITY BIT PROGRAMMING AND VERIFICATION CHARACTERISTICS**

TA = 21°C to 27°C, VCC = 4.5V to 5.5V, VSS = 0V

Symbol	Parameter	Min	Max	Units
V <sub>pp</sub>	Programming Supply Voltage	20.5	21.5	V
I <sub>pp</sub>	Programming Current		30	mA
1/TCLCL	Oscillator Frequency	4	6	MHz
TAVGL	Address Setup to $\overline{\text{PROG}}$	48TCLCL		
TGHAX	Address Hold after $\overline{\text{PROG}}$	48TCLCL		
TDVGL	Data Setup to $\overline{\text{PROG}}$	48TCLCL		
TGHDX	Data Hold after $\overline{\text{PROG}}$	48TCLCL		
TEHSH	$\overline{\text{ENABLE}}$ High to V <sub>pp</sub>	48TCLCL		
TSHGL	V <sub>pp</sub> Setup to $\overline{\text{PROG}}$	10		μsec
TGHSL	V <sub>pp</sub> Hold after $\overline{\text{PROG}}$	10		μsec
TGLGH	$\overline{\text{PROG}}$ Width	45	55	msec
TAVQV	Address to Data Valid		48TCLCL	
TELQV	$\overline{\text{ENABLE}}$ to Data Valid		48TCLCL	
TEHQZ	Data Float after $\overline{\text{ENABLE}}$	0	48TCLCL	

**EPROM PROGRAMMING, SECURITY BIT PROGRAMMING  
AND VERIFICATION WAVEFORMS**

