



JM38510/10104

JAN SINGLE LOW-INPUT-CURRENT OPERATIONAL AMPLIFIER (EXTERNALLY COMPENSATED)

Precision Monolithics Inc.

GENERAL DESCRIPTION

This data sheet covers the electrical requirements for a monolithic, low input-current, externally-compensated operational amplifier as specified in MIL-M-38510/101 for device type 04. Devices supplied to this data sheet are manufactured and tested at PMI's MIL-M-38510 certified facility and are listed in QPL-38510.

Complete device requirements will be found in MIL-M-38510 and MIL-M-38510/101 for Class B processed devices.

GENERIC CROSS-REFERENCE INFORMATION

This cross-reference information is presented for the convenience of the user. The generic-industry types listed may not have identical operational performance characteristics across the military temperature range or reliability factors equivalent to the MIL-M-38510 device.

Military Device Type
04

Generic-Industry Type
LM108A

CASE OUTLINE

Per MIL-M-38510, Appendix C, Case Outline A-1 (8 Lead Can), Package Type Designator "G"; and Appendix C, Case Outline D-4 (8 Lead Dual-in-Line), Package Type Designator "P".

ORDERING INFORMATION

JAN SLASH SHEET	PMI DEVICE
JM38510/10104BGC	PM108AJ1/38510
JM38510/10104BGA	PM108AJ5/38510
JM38510/10104SGA*	PM108AJ5/38510*
JM38510/10104BPB	PM108AZ2/38510
JM38510/10104BPA	PM108AZ5/38510

* JM38510/10104SGA, Class S device currently undergoing part I qualification. Consult PMI for availability.

PIN CONNECTIONS

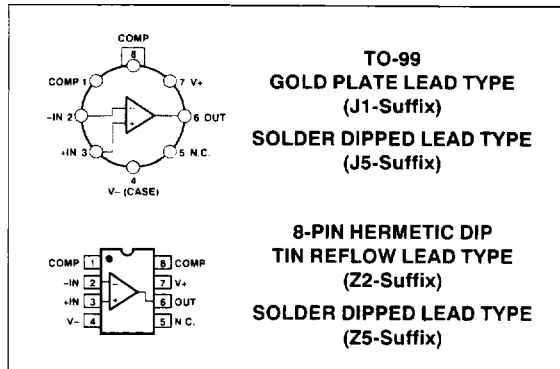

SIMPLIFIED SCHEMATIC

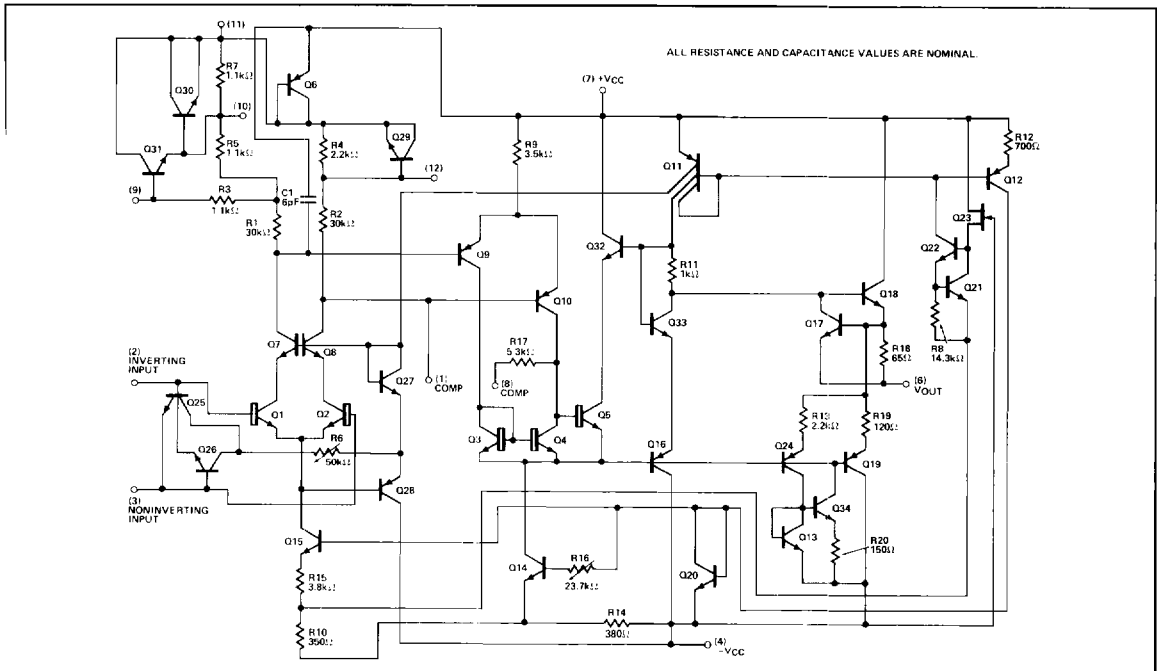

ELECTRICAL CHARACTERISTICS at $5V \leq \pm V_{CC} \leq 20V$ and $-55^{\circ}C \leq T_A \leq +125^{\circ}C$, unless otherwise noted.

PARAMETER	SYMBOL	CONDITIONS	MIN	MAX	UNITS
Input Offset Voltage	V_{IO}	(Note 2) $T_A = +25^{\circ}C$ $R_S = 50\Omega$ $-55^{\circ}C \leq T_A \leq +125^{\circ}C$	-0.5 -1.0	+0.5 +1.0	mV
Input Offset Voltage Temperature Sensitivity	$\Delta V_{IO}/\Delta T$	ΔT_A from $-55^{\circ}C$ to $+25^{\circ}C$ ΔT_A from $+25^{\circ}C$ to $+125^{\circ}C$	-5.0 -5.0	+5.0 +5.0	$\mu V/C^{\circ}$
Input Offset Current	I_{IO}	(Note 2) $T_A = +25^{\circ}C$ $-55^{\circ}C \leq T_A \leq +125^{\circ}C$	-0.2 -0.4	+0.2 +0.4	nA
Input Offset Current Temperature Sensitivity	$\Delta I_{IO}/\Delta T$	ΔT_A from $-55^{\circ}C$ to $+25^{\circ}C$ ΔT_A from $+25^{\circ}C$ to $+125^{\circ}C$	-2.5 -2.5	+2.5 +2.5	$pA^{\circ}C$
Input Bias Current	$+I_{IB}, -I_{IB}$	(Note 2) $T_A = +25^{\circ}C$ $T_A = -55^{\circ}C$ $T_A = +125^{\circ}C$	-0.1 -0.1 -1.0	2.0 3.0 2.0	nA
Power Supply Rejection Ratio	+PSRR	$+V_{CC} = 10V$ $-V_{CC} = 20V$ $R_S = 50\Omega$ $T_A = +25^{\circ}C$ $-55^{\circ}C \leq T_A \leq +125^{\circ}C$	-16 -16	+16 +16	$\mu V/V$
Power Supply Rejection Ratio	-PSRR	$+V_{CC} = 20V$ $-V_{CC} = -10V$ $R_S = 50\Omega$ $T_A = +25^{\circ}C$ $-55^{\circ}C \leq T_A \leq +125^{\circ}C$	-16 -16	+16 +16	$\mu V/V$
Input Voltage Common-Mode Rejection	CMR	$\pm V_{CC} = 20V$ $V_{IN} = \pm 15V$ $R_S = 50\Omega$	96	—	dB
Adjustment For Input Offset Voltage	V_{IO} ADJ(+)	$\pm V_{CC} = 20V$		No External Adjustment	mV
Adjustment For Input Offset Voltage	V_{IO} ADJ(-)	$\pm V_{CC} = 20V$		No External Adjustment	mV
Output Short-Circuit Current (For Positive Output)	$I_{OS(+)}$	$\pm V_{CC} = 15V, I \leq 25ms$ (Note 3)	15	—	mA
Output Short-Circuit Current (For Negative Output)	$I_{OS(-)}$	$\pm V_{CC} = 15V, I \leq 25ms$ (Note 3)	—	15	mA
Supply Current	I_{CC}	$\pm V_{CC} = 15V$ $T_A = -55^{\circ}C$ $T_A = +25^{\circ}C$ $T_A = +125^{\circ}C$	— — —	0.8 0.6 0.6	mA
Output Voltage Swing (Maximum)	V_{OP}	$\pm V_{CC} = 20V, R_L = 10k\Omega$ $\pm V_{CC} = 20V, R_L = 2k\Omega$	+16 —	— —	V
Open-Loop Voltage Gain (Single Ended) (Note 1)	$A_{VS(\pm)}$	$\pm V_{CC} = 20V$ $R_L = 10k\Omega$ $T_A = +25^{\circ}C$ $V_{OUT} = \pm 15V$ $-55^{\circ}C \leq T_A \leq +125^{\circ}C$	80 40	— —	V/mV
Open-Loop Voltage Gain (Single Ended) (Note 1)	A_{VS}	$\pm V_{CC} = 5V$ $R_L = 10k\Omega$ $V_{OUT} = \pm 2V$	80	—	V/mV
Transient Response Rise Time	$TR_{(tr)}$	$C_F = 10pF$	—	1000	n
Transient Response Overshoot	$TR_{(OS)}$	$C_F = 10pF$	—	50	%
Noise (Referred to Input) Broadband	N_I (BB)	$V_{CC} = 20V$ Bandwidth = 5kHz $T_A = +25^{\circ}C$	—	15	μV rms
Noise (Referred to Input) Popcorn	N_I (PC)	$\pm V_{CC} = 20V$ Bandwidth = 5kHz $T_A = +25^{\circ}C$	—	40	μV pea

NOTES:

- Note that gain is not specified at $V_{IO(ADJ)}$ extremes. Some gain reduction is usually seen at $V_{IO(ADJ)}$ extremes. For closed-loop applications (closed-loop gain less than 1,000), the open-loop tests (A_{VS}) prescribed herein should guarantee a positive, reasonably linear, transfer characteristic. They do not, however, guarantee that the open-loop gain is linear, or even positive, over the operating range. If either of these requirements exist (positive open-loop gain or open-loop gain linearity), they should be specified in the individual procurement document as additional requirements.
- Tests at common-mode $V_{CM} = 0, V_{CM} = -15V$, and $V_{CM} = +15V$.
- Continuous short-circuit limits will be considerably less than the indicated limits. Continuous I_{OS} at $T_A = -75^{\circ}C$ will cause T_J to exceed the maximum $T_J = 175^{\circ}C$.

ELECTRICAL CHARACTERISTICS at $5V \leq \pm V_{CC} \leq 20V$ and $-55^{\circ}C \leq T_A \leq +125^{\circ}C$, unless otherwise noted. (Continued)

PARAMETER	SYMBOL	CONDITIONS	MIN	MAX	UNITS	
Slew Rate	SR (+)	$A_V = 1$	$-55^{\circ}C \leq T_A \leq 25^{\circ}C$	0.05	—	V/ μ sec
		$V_{IN} = +5V$	$T_A = 125^{\circ}C$	0.05	—	
Slew Rate	SR (-)	$A_V = 1$	$-55^{\circ}C \leq T_A \leq 25^{\circ}C$	0.05	—	V/ μ sec
		$V_{IN} = \pm 5V$	$T_A = 125^{\circ}C$	0.05	—	

NOTES:

1. Note that gain is not specified at $V_{IO,ADJ}$, extremes. Some gain reduction is usually seen at $V_{IO,ADJ}$, extremes. For closed-loop applications (closed-loop gain less than 1,000), the open-loop tests (A_{VS}) prescribed herein should guarantee a positive, reasonably linear, transfer characteristic. They do not, however, guarantee that the open-loop gain is linear, or even positive, over the operating range. If either of these requirements exist; positive open-loop gain or open-loop gain linearity, they should be

specified in the individual procurement document as additional requirements.

2. Tests at common-mode $V_{CM} = 0$, $V_{CM} = -15V$, and $V_{CM} = +15V$.
3. Continuous short-circuit limits will be considerably less than the indicated test limits. Continuous I_{OS} at $T_A \leq 75^{\circ}C$ will cause T_J to exceed the maximum of $175^{\circ}C$.

For Other Test Circuit Diagrams, See MIL-M-38510/101

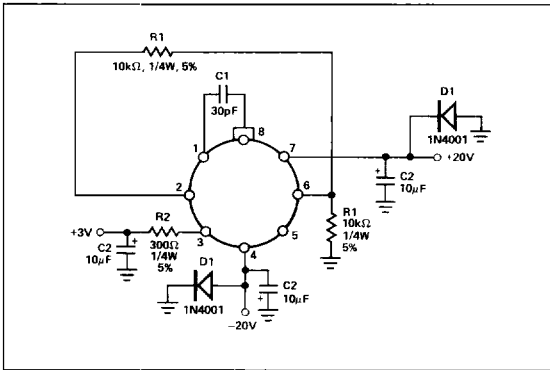
BURN-IN CIRCUIT

POWER AND THERMAL CHARACTERISTICS

Package	Case outline	Maximum allowable power dissipation	Maximum θ_{J-C}	Maximum θ_{J-A}
8 Lead Can (TO-99)	G	330mW at $T_A = 125^{\circ}C$	40 $^{\circ}C/W$	150 $^{\circ}C/W$
8 Lead Hermetic (Dual-in-Line)	P	417mW at $T_A = 125^{\circ}C$	50 $^{\circ}C/W$	120 $^{\circ}C/W$



OPERATIONAL AMPLIFIERS/BUFFERS