

100302

Low Power Quint 2-Input OR/NOR Gate

General Description

The 100302 is a monolithic quint 2-input OR/NOR gate with common enable. All inputs have 50 kΩ pull-down resistors and all outputs are buffered.

- 2000V ESD protection
- Pin/function compatible with 100102
- Voltage compensated operating range = -4.2V to -5.7V
- Standard Microcircuit Drawing (SMD) 5962-9152802

Features

- 43% power reduction of the 100102

Logic Symbol

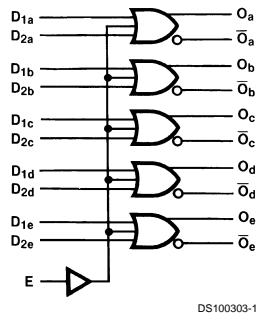

Pin Names	Description
$D_{1a}-D_{2e}$	Data Inputs
E	Enable Input
O_a-O_e	Data Outputs
$\bar{O}_a-\bar{O}_e$	Complementary Data Outputs

Truth Table

D_{1x}	D_{2x}	E	O_x	\bar{O}_x
L	L	L	L	H
L	L	H	H	L
L	H	L	H	L
L	H	H	H	L
H	L	L	H	L
H	L	H	H	L
H	H	L	H	L
H	H	H	H	L

H = HIGH Voltage Level
L = LOW Voltage Level

Connection Diagrams

24-Pin DIP

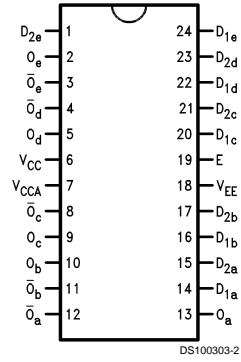

24-Pin Quad Cerpak

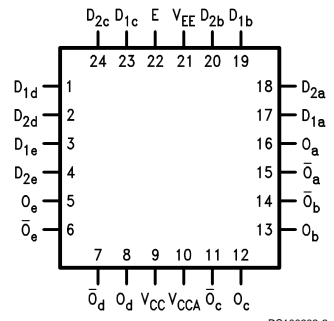

Absolute Maximum Ratings (Note 1)

If Military/Aerospace specified devices are required, please contact the National Semiconductor Sales Office/Distributors for availability and specifications.

Above which the useful life may be impaired	
Storage Temperature (T_{STG})	-65°C to +150°C
Maximum Junction Temperature (T_J)	
Ceramic	+175°C
V_{EE} Pin Potential to	
Ground Pin	-7.0V to +0.5V
Input Voltage (DC)	V_{EE} to +0.5V
Output Current (DC Output HIGH)	-50 mA

ESD (Note 2)

≥2000V

Recommended Operating Conditions

Case Temperature (T_C)	
Military	-55°C to +125°C
Supply Voltage (V_{EE})	-5.7V to -4.2V

Note 1: Absolute maximum ratings are those values beyond which the device may be damaged or have its useful life impaired. Functional operation under these conditions is not implied.

Note 2: ESD testing conforms to MIL-STD-883, Method 3015.

Military Version DC Electrical Characteristics

$V_{EE} = -4.2V$ to $-5.7V$, $V_{CC} = V_{CCA} = GND$, $T_C = -55°C$ to $+125°C$ (Note 5)

Symbol	Parameter	Min	Max	Units	T_C	Conditions	Notes	
V_{OH}	Output HIGH Voltage	-1025	-870	mV	0°C to +125°C	$V_{IN} = V_{IH(Max)}$ or $V_{IL} (Min)$	Loading with 50Ω to -2.0V	(Notes 3, 4, 5)
		-1085	-870	mV	-55°C			
V_{OL}	Output LOW Voltage	-1830	-1620	mV	0°C to +125°C	$V_{IN} = V_{IH(Max)}$ or $V_{IL} (Min)$	Loading with 50Ω to -2.0V	(Notes 3, 4, 5)
		-1830	-1555	mV	-55°C			
V_{OHC}	Output HIGH Voltage	-1035		mV	0°C to +125°C	$V_{IN} = V_{IH(Max)}$ or $V_{IL} (Min)$	Loading with 50Ω to -2.0V	(Notes 3, 4, 5)
		-1085		mV	-55°C			
V_{OLC}	Output LOW Voltage		-1610	mV	0°C to +125°C	$V_{IN} = V_{IH(Max)}$ or $V_{IL} (Min)$	Loading with 50Ω to -2.0V	(Notes 3, 4, 5)
			-1555	mV	-55°C			
V_{IH}	Input HIGH Voltage	-1165	-870	mV	-55°C to +125°C	Guaranteed HIGH Signal for All Inputs	(Notes 3, 4, 5, 6)	
V_{IL}	Input LOW Voltage	-1830	-1475	mV	-55°C to +125°C	Guaranteed LOW Signal for All Inputs	(Notes 3, 4, 5, 6)	
I_{IL}	Input LOW Current	0.50		μA	-55°C to +125°C	$V_{EE} = -4.2V$ $V_{IN} = V_{IH} (Max)$	(Notes 3, 4, 5)	
I_{IH}	Input HIGH Current		240	μA	0°C to +125°C	$V_{EE} = -5.7V$ $V_{IN} = V_{IL} (Min)$	(Notes 3, 4, 5)	
			340	μA	-55°C			
I_{EE}	Power Supply Current	-48	-17	mA	-55°C to +125°C	Inputs Open	(Notes 3, 4, 5, 6)	

Note 3: F100K 300 Series cold temperature testing is performed by temperature soaking (to guarantee junction temperature equals -55°C), then testing immediately without allowing for the junction temperature to stabilize due to heat dissipation after power-up. This provides "cold start" specs which can be considered a worst case condition at cold temperatures.

Note 4: Screen tested 100% on each device at -55°C, +25°C, and +125°C, Subgroups 1, 2, 3, 7, and 8.

Note 5: Sample tested (Method 5005, Table I) on each manufactured lot at -55°C, +25°C, and +125°C, Subgroups A1, 2, 3, 7, and 8.

Note 6: Guaranteed by applying specified input condition and testing V_{OH}/V_{OL} .

AC Electrical Characteristics

$V_{EE} = -4.2V$ to $-5.7V$, $V_{CC} = V_{CCA} = GND$

Symbol	Parameter	$T_C = -55°C$		$T_C = +25°C$		$T_C = +125°C$		Units	Conditions	Notes
		Min	Max	Min	Max	Min	Max			
t_{PLH}	Propagation Delay	0.30	1.80	0.40	1.50	0.40	1.70	ns	Figures 1, 2	(Notes 7, 8, 9, 10, 11)
t_{PHL}	Data to Output									
t_{PLH}	Propagation Delay	0.60	2.60	0.80	2.30	0.80	2.80	ns		
t_{PHL}	Enable to Output									
t_{TLH}	Transition Time	0.30	1.20	0.30	1.20	0.30	1.20	ns		(Note 10)
t_{THL}	20% to 80%, 80% to 20%									

Note 7: F100K 300 Series cold temperature testing is performed by temperature soaking (to guarantee junction temperature equals -55°C), then testing immediately after power-up. This provides "cold start" specs which can be considered a worst case condition at cold temperatures.

AC Electrical Characteristics (Continued)

Note 8: Screen tested 100% on each device at +25°C temperature only, Subgroup A9.

Note 9: Sample tested (Method 5005, Table I) on each manufactured lot at +25°C, Subgroup A9, and at +125°C and -55°C temperatures, Subgroups A10 and A11.

Note 10: Not tested at +25°C, +125°C, and -55°C temperature (design characterization data).

Note 11: The propagation delay specified is for single output switching. Delays may vary up to 100 ps with multiple outputs switching.

Test Circuitry

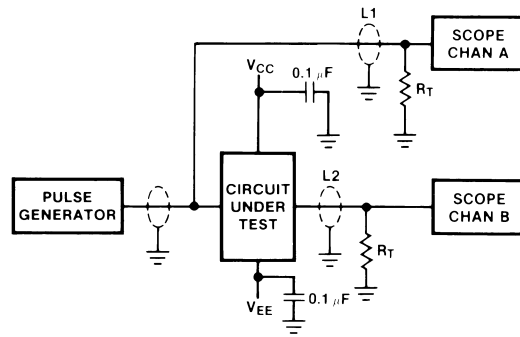

DS100303-5

Notes:

$V_{CC}, V_{CCA} = +2V, V_{EE} = -2.5V$

L1 and L2 = equal length 50Ω impedance lines

$R_T = 50\Omega$ terminator internal to scope

Decoupling 0.1 μF from GND to V_{CC} and V_{EE}

All unused outputs are loaded with 50Ω to GND

C_L = Fixture and stray capacitance ≤ 3 pF

FIGURE 1. AC Test Circuit

Switching Waveforms

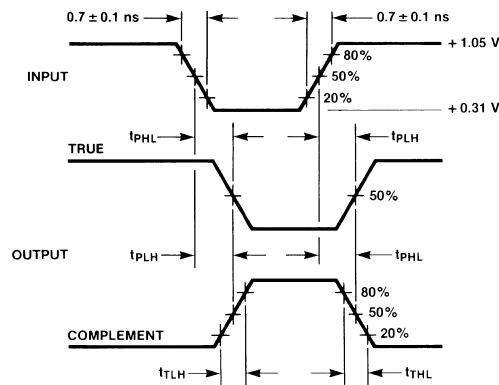

DS100303-6

FIGURE 2. Propagation Delay and Transition Times

Physical Dimensions inches (millimeters) unless otherwise noted

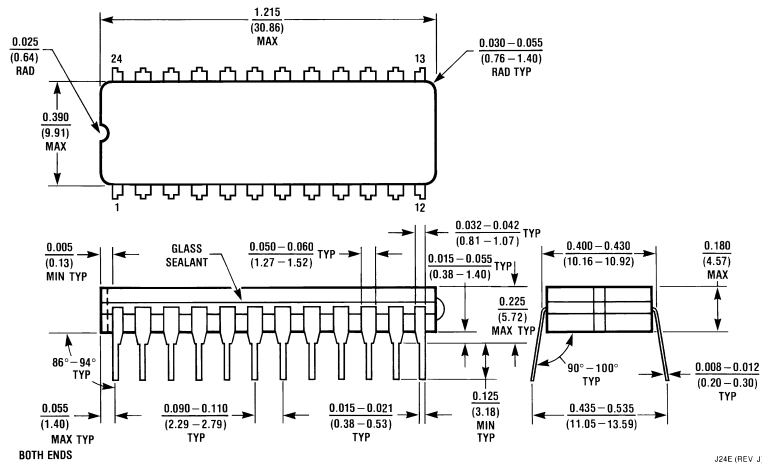

24-Lead Ceramic Dual-In-Line Package (0.400" Wide) (D)
NS Package Number J24E

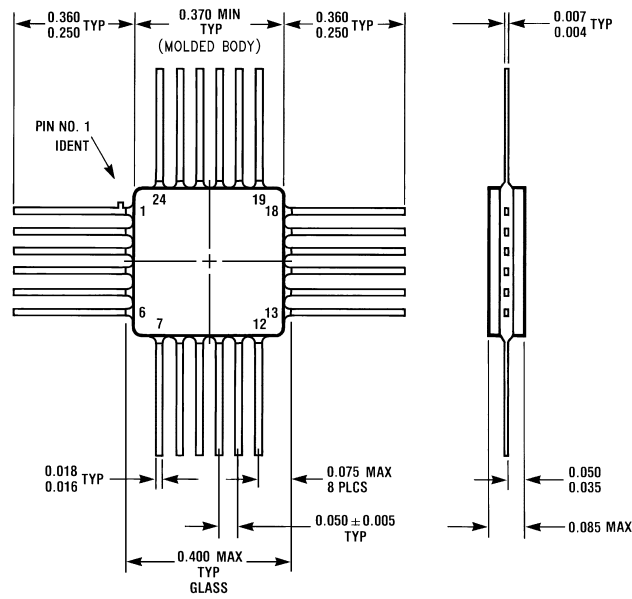

24-Lead Quad Cerpak (F)
NS Package Number W24B

LIFE SUPPORT POLICY

NATIONAL'S PRODUCTS ARE NOT AUTHORIZED FOR USE AS CRITICAL COMPONENTS IN LIFE SUPPORT DEVICES OR SYSTEMS WITHOUT THE EXPRESS WRITTEN APPROVAL OF THE PRESIDENT OF NATIONAL SEMICONDUCTOR CORPORATION. As used herein:

1. Life support devices or systems are devices or systems which, (a) are intended for surgical implant into the body, or (b) support or sustain life, and whose failure to perform when properly used in accordance with instructions for use provided in the labeling, can be reasonably expected to result in a significant injury to the user.
2. A critical component in any component of a life support device or system whose failure to perform can be reasonably expected to cause the failure of the life support device or system, or to affect its safety or effectiveness.



National Semiconductor Corporation
Americas
Tel: 1-800-272-9959
Fax: 1-800-737-7018
Email: support@nsc.com

www.national.com

National Semiconductor Europe
Fax: +49 (0) 1 80-530 85 86
Email: europe.support@nsc.com
Deutsch Tel: +49 (0) 1 80-530 85 85
English Tel: +49 (0) 1 80-532 78 32
Français Tel: +49 (0) 1 80-532 93 58
Italiano Tel: +49 (0) 1 80-534 16 80

National Semiconductor Asia Pacific Customer Response Group
Tel: 65-2544466
Fax: 65-2504466
Email: sea.support@nsc.com

National Semiconductor Japan Ltd.
Tel: 81-3-5620-6175
Fax: 81-3-5620-6179

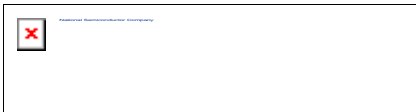

100302 Low Power Quint 2-Input OR/NOR Gate

Contents

- [General Description](#)
- [Features](#)
- [Datasheet](#)
- [Package Availability, Models, Samples & Pricing](#)



General Description

The 100302 is a monolithic quint 2-input OR/NOR gate with common enable. All inputs have 50 k Ohm pull-down resistors and all outputs are buffered.

Features



- 43% power reduction of the 100102
 - 2000V ESD protection
 - Pin/function compatible with 100102
 - Voltage compensated operating range = -4.2V to -5.7V
 - Standard Microcircuit Drawing (SMD) 5962-9152802
-

Datasheet

Title	Size (in Kbytes)	Date	 View Online	 Download	 Receive via Email
100302 Low Power Quint 2-Input OR/NOR Gate	106 Kbytes	17-Aug-98	View Online	Download	Receive via Email
100302 Mil-Aero Datasheet MN100302-X	104 Kbytes		View Online	Download	Receive via Email

Please use [Adobe Acrobat](#) to view PDF file(s).
If you have trouble printing, see [Printing Problems](#).

Package Availability, Models, Samples & Pricing

Part Number	Package		Status	Models		Samples & Electronic Orders	Budgetary Pricing		Std Pack Size	Package Marking
	Type	# pins		SPICE	IBIS		Quantity	\$US each		
5962-9152802MXA	Cerdip	24	Full production	N/A	N/A		50+	\$20.4000	tube of 15	[logo]cZcSc4cA\$E 100302DMQB /Q 5962-9152802MXA
5962-9152802MYA	Cerquad	24	Full production	N/A	N/A		50+	\$20.4000	tube of 14	[logo]cZcSc4cA Q\$E 100302 FMQB 5962 -9152802 MYA
5962-9152802VXA	Cerdip	24	Full production	N/A	N/A	.	50+	\$265.0000	tube of 15	[logo]cZcSc4cA\$E 100302J-QMLV 5962-9152802VXA
5962-9152802VYA	Cerquad	24	Full production	N/A	N/A	.	50+	\$245.0000	tube of 14	[logo]cZcSc4cA 100302W- QMLV 5962 -9152802 VYA \$E
100302 MW8	wafer		Full production	N/A	N/A	.			N/A	-

[Information as of 1-Sep-2000]

Quick Search

[Parametric
Search](#)

[System
Diagrams](#)

[Product
Tree](#)

[Home](#)

[About Languages](#) . [About the Site](#) . [About "Cookies"](#)

National is [QS 9000 Certified](#) . [Privacy/Security](#)

[Copyright](#) © National Semiconductor Corporation

[Preferences](#) . [Feedback](#)