

# TYPES SN54154, SN54L154, SN74154 4-LINE TO 16-LINE DECODERS/DEMULTIPLEXERS

DECEMBER 1972—REVISED DECEMBER 1983

- '154 is Ideal for High-Performance Memory Decoding
- 'L154 is Designed for Power-Critical Applications
- Decodes 4 Binary-Coded Inputs into One of 16 Mutually Exclusive Outputs
- Performs the Demultiplexing Function by Distributing Data From One Input Line to Any One of 16 Outputs
- Input Clamping Diodes Simplify System Design
- High Fan-Out, Low-Impedance, Totem-Pole Outputs
- Fully Compatible with Most TTL and MSI Circuits

SN54154 . . . J OR W PACKAGE  
SN54L154 . . . J PACKAGE  
SN74154 . . . J OR N PACKAGE  
(TOP VIEW)

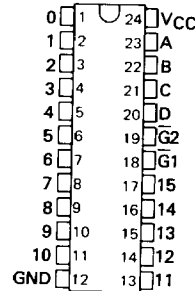

TYPE	TYPICAL AVERAGE PROPAGATION DELAY		TYPICAL POWER DISSIPATION
	3 LEVELS OF LOGIC	STROBE	
'154	23 ns	19 ns	170 mW
'L154	46 ns	38 ns	85 mW

### description

Each of these monolithic, 4-line-to-16-line decoders utilizes TTL circuitry to decode four binary-coded inputs into one of sixteen mutually exclusive outputs when both the strobe inputs,  $\overline{G1}$  and  $\overline{G2}$ , are low. The demultiplexing function is performed by using the 4 input lines to address the output line, passing data from one of the strobe inputs with the other strobe input low. When either strobe input is high, all outputs are high. These demultiplexers are ideally suited for implementing high-performance memory decoders. For ultra-high speed systems, SN54S138/SN74S138 and SN54S139/SN74S139 are recommended.

These circuits are fully compatible for use with most other TTL circuits. All inputs are buffered and input clamping diodes are provided to minimize transmission-line effects and thereby simplify system design.

The SN54154 and SN54L154 are characterized for operation over the full military temperature range of  $-55^{\circ}\text{C}$  to  $125^{\circ}\text{C}$ . The SN74154 is characterized for operation from  $0^{\circ}\text{C}$  to  $70^{\circ}\text{C}$ .

### logic symbol

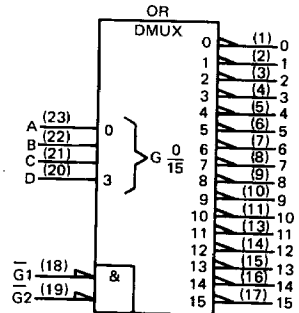
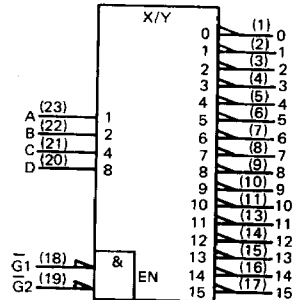

Pin numbers shown on logic notation are for J or N packages.

3

TTL DEVICES

**PRODUCTION DATA**  
This document contains information current as of publication date. Products conform to specifications per the terms of Texas Instruments standard warranty. Production processing does not necessarily include testing of all parameters.

**TEXAS  
INSTRUMENTS**

POST OFFICE BOX 225012 • DALLAS, TEXAS 75265

3-577



TYPES SN54154, SN54L154, SN74154  
4-LINE TO 16-LINE DECODERS/DEMULTIPLEXERS

logic diagram

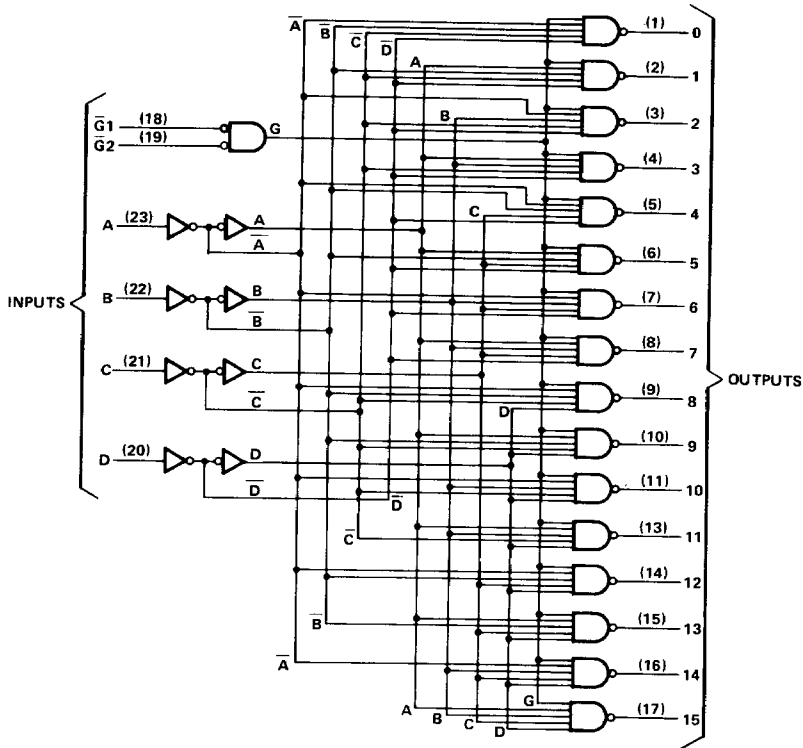

Pin numbers shown on logic notation are for J or N packages.

3

TTL DEVICES

# TYPES SN54154, SN74154

## 4-LINE TO 16-LINE DECODERS/DEMULTIPLEXERS

absolute maximum ratings over operating free-air temperature range (unless otherwise noted)

Supply voltage, $V_{CC}$ (see Note 1)	7 V
Input voltage	5.5 V
Operating free-air temperature range: SN54154 Circuits	-55°C to 125°C
SN74154 Circuits	0°C to 70°C
Storage temperature range	-65°C to 150°C

NOTE 1: Voltage values are with respect to network ground terminal.

recommended operating conditions

	SN54154			SN74154			UNIT
	MIN	NOM	MAX	MIN	NOM	MAX	
Supply voltage, $V_{CC}$	4.5	5	5.5	4.75	5	5.25	V
High-level output current, $I_{OH}$			-800			-800	$\mu$ A
Low-level output current, $I_{OL}$			16			16	mA
Operating free-air temperature, $T_A$	-55		125	0		70	°C

electrical characteristics over recommended operating free-air temperature range (unless otherwise noted)

PARAMETER	TEST CONDITIONS†	SN54154			SN74154			UNIT
		MIN	TYP	MAX	MIN	TYP‡	MAX	
$V_{IH}$ High-level input voltage		2			2			V
$V_{IL}$ Low-level input voltage				0.8			0.8	V
$V_{IK}$ Input clamp voltage	$V_{CC} = \text{MIN}, I_I = -12 \text{ mA}$			-1.5			-1.5	V
$V_{OH}$ High-level output voltage	$V_{CC} = \text{MIN}, V_{IH} = 2 \text{ V}, V_{IL} = 0.8 \text{ V}, I_{OH} = -800 \mu\text{A}$	2.4	3.4		2.4	3.4		V
$V_{OL}$ Low-level output voltage	$V_{CC} = \text{MIN}, V_{IH} = 2 \text{ V}, V_{IL} = 0.8 \text{ V}, I_{OL} = 16 \text{ mA}$		0.2	0.4		0.2	0.4	V
$I_I$ Input current at maximum input voltage	$V_{CC} = \text{MAX}, V_I = 5.5 \text{ V}$			1			1	mA
$I_{IH}$ High-level input current	$V_{CC} = \text{MAX}, V_I = 2.4 \text{ V}$			40			40	$\mu$ A
$I_{IL}$ Low-level input current	$V_{CC} = \text{MAX}, V_I = 0.4 \text{ V}$			-1.6			-1.6	mA
$I_{OS}$ Short-circuit output current§	$V_{CC} = \text{MAX}$	-20		-55	-18		-57	mA
$I_{CC}$ Supply current	$V_{CC} = \text{MAX}, \text{ See Note 2}$		34	49		34	56	mA

† For conditions shown as MIN or MAX, use the appropriate value specified under recommended operating conditions for the applicable type.

‡ All typical values are at  $V_{CC} = 5 \text{ V}, T_A = 25^\circ \text{C}$ .

§ Not more than one output should be shorted at a time.

NOTE 2:  $I_{CC}$  is measured with all inputs grounded and all outputs open.

switching characteristics,  $V_{CC} = 5 \text{ V}, T_A = 25^\circ \text{C}$

PARAMETER	TEST CONDITIONS	MIN	TYP	MAX	UNIT
$t_{PLH}$ Propagation delay time, low-to-high-level output, from A, B, C, or D inputs through 3 levels of logic	$C_L = 15 \text{ pF}, R_L = 400 \Omega,$ See Note 3		24	36	ns
$t_{PHL}$ Propagation delay time, high-to-low-level output, from A, B, C, or D inputs through 3 levels of logic			22	33	ns
$t_{PLH}$ Propagation delay time, low-to-high-level output, from either strobe input			20	30	ns
$t_{PHL}$ Propagation delay time, high-to-low-level output, from either strobe input			18	27	ns

NOTE 3: See General Information Section for load circuits and voltage waveforms

3

TTL DEVICES

# TYPE SN54L154 4-LINE TO 16-LINE DECODER/DEMULTIPLEXER

## absolute maximum ratings over operating free-air temperature range (unless otherwise noted)

Supply voltage, $V_{CC}$ (see Note 1)	7 V
Input voltage	5.5 V
Operating free-air temperature	- 55°C to 125°C
Storage temperature range	- 65°C to 150°C

NOTE 1: Voltage values are with respect to network ground terminal.

## recommended operating conditions

	SN54L154			UNIT
	MIN	NOM	MAX	
$V_{CC}$ Supply voltage	4.5	5	5.5	V
$V_{IH}$ High-level input voltage	2			V
$V_{IL}$ Low-level input voltage			0.8	V
$I_{OH}$ High-level output current			- 0.4	mA
$I_{OL}$ Low-level output current			8	mA
$T_A$ Operating free-air temperature	- 55	125		°C

## electrical characteristics over recommended operating free-air temperature range (unless otherwise noted)

PARAMETER	TEST CONDITIONS†	SN54L154			UNIT
		MIN	TYP‡	MAX	
$V_{IK}$	$V_{CC} = \text{MIN}, I_I = -12 \text{ mA}$			- 1.5	V
$V_{OH}$	$V_{CC} = \text{MIN}, V_{IH} = 2 \text{ V}, V_{IL} = 0.8 \text{ V}, I_{OH} = -0.4 \text{ mA}$	2.4	3.4		V
$V_{OL}$	$V_{CC} = \text{MIN}, V_{IH} = 2 \text{ V}, V_{IL} = 0.8 \text{ V}, I_{OL} = 8 \text{ mA}$		0.2	0.4	V
$I_I$	$V_{CC} = \text{MAX}, V_I = 5.5 \text{ V}$			1	mA
$I_{IH}$	$V_{CC} = \text{MAX}, V_I = 2.4 \text{ V}$			20	µA
$I_{IL}$	$V_{CC} = \text{MAX}, V_I = 0.4 \text{ V}$			- 0.8	mA
$I_{OS}§$	$V_{CC} = \text{MAX}$	- 9		- 29	mA
$I_{CC}$	$V_{CC} = \text{MAX},$ See Note 2		17	25	mA

† For conditions shown as MIN or MAX, use the appropriate value specified under recommended operating conditions.

‡ All typical values are at  $V_{CC} = 5 \text{ V}, T_A = 25^\circ\text{C}$ .

§ Not more than one output should be shorted at a time.

NOTE 2:  $I_{CC}$  is measured with all outputs open and all inputs grounded.

## switching characteristics, $V_{CC} = 5 \text{ V}, T_A = 25^\circ\text{C}$ (see note 3)

PARAMETER	FROM (INPUT)	TO (OUTPUT)	TEST CONDITIONS	MIN	TYP	MAX	UNIT
$t_{PLH}$	A, B, C, D	Any	$R_L = 800 \Omega, C_L = 15 \text{ pF}$		48	72	ns
$t_{PHL}$					44	66	ns
$t_{PLH}$	Strobe				40	60	ns
$t_{PHL}$					36	54	ns

NOTE 3: See General Information Section for load circuits and voltage waveforms.

3

TTL DEVICES