

Fault Protected Single 8-Channel/Differential 4-Channel Analog Multiplexers

Features

- Fault and Overvoltage Protection
- All Channels Off When Power Off
- Latchup-Proof
- Fast Switching— T_A : 200 ns
- Break-Before-Make Switching
- Low On-Resistance: 180 Ω
- Low Power Consumption: 3 mW
- TTL and CMOS Compatible Inputs

Benefits

- Improved Ruggedness
- Power Loss Protection
- Prevents Adjacent Channel Crosstalk
- Standard Logic Interface
- Superior Accuracy
- Fast Settling Time

Applications

- Data Acquisition Systems
- Industrial Process Control Systems
- Avionics Test Equipment
- High-Rel Control Systems
- Telemetry

Description

The DG458 and DG459 are 8-channel single-ended and 4-channel differential analog multiplexers, respectively, incorporating fault protection. A series n-p-n MOSFET structure provides device and signal-source protection in the event of power loss or overvoltages. Under fault conditions the multiplexer input (or output) appears as an open circuit and only a few nanoamperes of leakage current will flow. This protects not only the multiplexer and the circuitry following it, but also protects the sensors or signal sources which drive the multiplexer.

The DG458 and DG459 can withstand continuous overvoltage inputs up to ± 35 V. All digital inputs have TTL compatible logic thresholds. Break-before-make operation prevents channel-to-channel interference.

The DG458 and DG459 are improved pin-compatible replacements for HI-508A/509A and MAX358/359 multiplexers.

Functional Block Diagrams and Pin Configurations

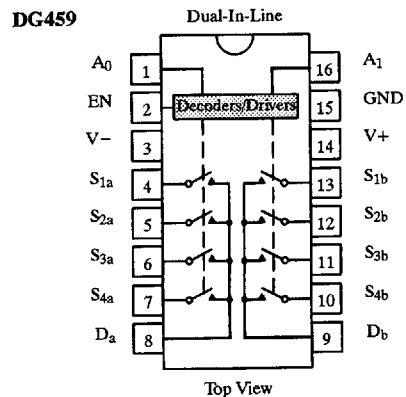
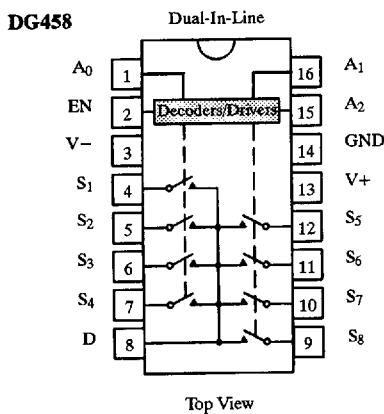

Truth Tables and Ordering Information

Truth Table — DG458

A ₂	A ₁	A ₀	EN	On Switch
X	X	X	0	None
0	0	0	1	1
0	0	1	1	2
0	1	0	1	3
0	1	1	1	4
1	0	0	1	5
1	0	1	1	6
1	1	0	1	7
1	1	1	1	8

Truth Table — DG459

A ₁	A ₀	EN	On Switch
X	X	0	None
0	0	1	1
0	1	1	2
1	0	1	3
1	1	1	4

Logic "0" = V_{AL} ≤ 0.8 V
 Logic "1" = V_{AH} ≥ 2.4 V
 X = Don't Care

Ordering Information

Temp Range	Package	Part Number
-40 to 85°C	16-Pin Plastic DIP	DG458DJ
		DG459DJ
-55 to 125°C	16-Pin CerDIP	DG458AK/883
		DG459AK/883
	LCC-20	DG458AZ/883
		DG459AZ/883

*Block Diagram and Pin Configuration not shown.

Absolute Maximum Ratings

V ₊ to V ₋	44 V
V ₊ to GND	22 V
V ₋ to GND	-25 V
V _{EN} , V _A Digital Input	(V ₋) -4 V to (V ₊) +4 V
V _S , Analog Input Overvoltage with Power On	(V ₋) -20 V to (V ₊) +20 V
V _S , Analog Input Overvoltage with Power Off	-35 V to +35 V
Continuous Current, S or D	20 mA
Peak Current, S or D (Pulsed at 1 ms, 10% Duty Cycle Max)	40 mA

Storage Temperature (AK Suffix)	-65 to 150°C
(DJ Suffix)	-65 to 125°C

Power Dissipation (Package) ^a	
16-Pin Plastic DIP ^b	600 mW
16-Pin CerDIP ^c	1000 mW
LCC-20 ^d	1000 mW

Notes:

- All leads soldered or welded to PC board.
- Derate 6.3 mW/°C above 25°C.
- Derate 12 mW/°C above 75°C.
- Derate 10 mW/°C above 75°C.

Specifications^a

Parameter	Symbol	Test Conditions Unless Otherwise Specified $V_+ = 15\text{ V}, V_- = -15\text{ V}$ $V_{AL} = 0.8\text{ V}, V_{AH} = 2.4\text{ V}$	Temp ^b	Typ ^c	A Suffix -55 to 125°C		D Suffix -40 to 85°C		Unit	
					Min ^d	Max ^d	Min ^d	Max ^d		
Analog Switch										
Analog Signal Range ^e	V_{ANALOG}		Full		-10	10	-10	10	V	
Drain-Source On-Resistance	$r_{DS(on)}$	$V_D = \pm 9.5\text{ V}, I_S = -400\ \mu\text{A}$	Room Full	0.45		1.2 1.5		1.5 1.8	k Ω	
		$V_D = \pm 5\text{ V}, I_S = -400\ \mu\text{A}$	Room	180		400		400	Ω	
$r_{DS(on)}$ Matching Between Channels ^h	$\Delta r_{DS(on)}$	$V_D = 0\text{ V}, I_S = -400\ \mu\text{A}$	Room	6					%	
Source Off Leakage Current	$I_{S(off)}$	$V_{EN} = 0\text{ V}$ $V_S = \pm 10\text{ V}, V_D = \mp 10\text{ V}$	Room Full	0.03	-0.5 -50	0.5 50	-1 -20	1 20	nA	
Drain Off Leakage Current	$I_{D(off)}$	$V_{EN} = 0\text{ V}$ $V_D = \pm 10\text{ V}$ $V_S = \mp 10\text{ V}$	DG458	Room Full	0.1	-1 -200	1 200	-1 -50		1 50
			DG459	Room Full	0.1	-1 -100	1 100	-2 -25		2 25
Differential Off Drain Leakage Current	I_{DIFF}	DG459 Only	Room		-50	50	-20	20		
Drain On Leakage Current	$I_{D(on)}$	$V_S = V_D = \pm 10\text{ V}$	DG458	Room Full	0.1	-2 -200	2 200	-5 -50		5 50
			DG459	Room Full	0.05	-2 -100	2 100	-5 -25		5 25
Fault										
Output Leakage Current (with Overvoltage)	$I_{D(off)}$	$V_S = \pm 33\text{ V}, V_D = 0\text{ V}$ See Figure 1	Room	0.02					nA	
Input Leakage Current (with Overvoltage)	$I_{S(off)}$	$V_S = \pm 25\text{ V}, V_D = \pm 10\text{ V}$ See Figure 1	Room	0.005	-5	5	-10	10	μA	
Input Leakage Current (with Power Supplies Off)		$V_S = \pm 25\text{ V}, V_{SUPS} = 0\text{ V}$ $V_D = A_0, A_1, A_2, EN = 0\text{ V}$	Room	0.001	-2	2	-5	5		
Digital Control										
Input Low Threshold	V_{AL}		Full			0.8		0.8	V	
Input Low Threshold	V_{AL}		Full		2.4		2.4			
Logic Input Control	I_A	$V_A = 2.4\text{ V}$ or 0.8 V	Full		-1	1	-1	1	μA	
Dynamic Characteristics										
Transition Time	t_A	See Figure 2	Room	200		500		500	ns	
Break-Before-Make Time	t_{OPEN}	See Figure 3	Room	45	10		10			
Enable Turn-On Time	$t_{ON(EN)}$	See Figure 4	Room Full	140		250 500		250 500		
Enable Turn-Off Time	$t_{OFF(EN)}$		Room Full	50		250 500		250 500		
Settling Time	t_s	To 0.1%	Room	0.5					μs	
		To 0.01%	Room	1.5						
Off Isolation	OIRR	$V_{EN} = 0\text{ V}, R_L = 1\text{ k}\Omega, C_L = 15\text{ pF}$ $V_S = 3\text{ V}_{RMS}, f = 100\text{ kHz}$	Room	90					dB	
Logic Input Capacitance	C_{in}	$f = 1\text{ MHz}$	Room	5					pF	
Source Off Capacitance	$C_{S(off)}$		Room	5						
Drain Off Capacitance	$C_{D(off)}$		DG458	Room	15					
			DG459	Room	10					
Drain On Capacitance	$C_{D(on)}$		DG458	Room	40					
			DG459	Room	35					

Specifications^a

Parameter	Symbol	Test Conditions Unless Otherwise Specified $V_+ = 15\text{ V}, V_- = -15\text{ V}$ $V_{AL} = 0.8\text{ V}, V_{AH} = 2.4\text{ V}^f$	Temp ^b	Typ ^c	A Suffix -55 to 125°C		D Suffix -40 to 85°C		Unit
					Min ^d	Max ^d	Min ^d	Max ^d	
Power Supplies									
Positive Supply Current	I+	$V_{EN} = 5.0\text{ or }0\text{ V}, V_A = 0\text{ V}$	Room Full	0.05		0.1 0.2		0.1 0.2	mA
Negative Supply Current	I-		Room Full	-0.01	-0.1 -0.2		-0.1 -0.2		
Power Supply Range for Continuous Operation			Room		±4.5	±18	±4.5	±18	V

Notes:

- a. Refer to PROCESS OPTION FLOWCHART (Section 5 of the 1994 Data Book or FaxBack number 7103).
- b. Room = 25°C, Full = as determined by the operating temperature suffix.
- c. Typical values are for DESIGN AID ONLY, not guaranteed nor subject to production testing.
- d. The algebraic convention whereby the most negative value is a minimum and the most positive a maximum, is used in this data sheet.
- e. Guaranteed by design, not subject to production test.
- f. V_{IN} = input voltage to perform proper function.
- g. When the analog signal exceeds the +13.5 V or -12 V, $r_{DS(on)}$ starts to rise until only leakage currents flow.
- h.
$$\Delta r_{DS(on)} = \left(\frac{r_{DS(on) \text{ MAX}} - r_{DS(on) \text{ MIN}}}{r_{DS(on) \text{ AVE}}} \right) \times 100\%$$

Typical Characteristics

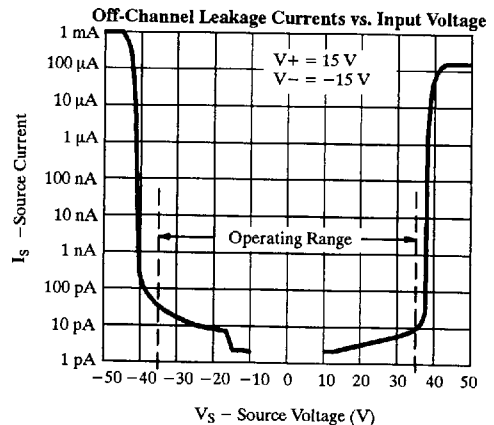
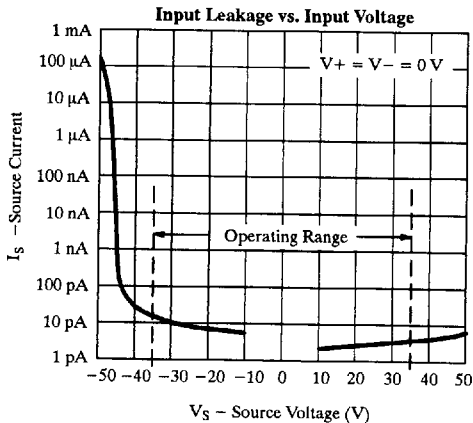

Typical Characteristics (Cont'd)

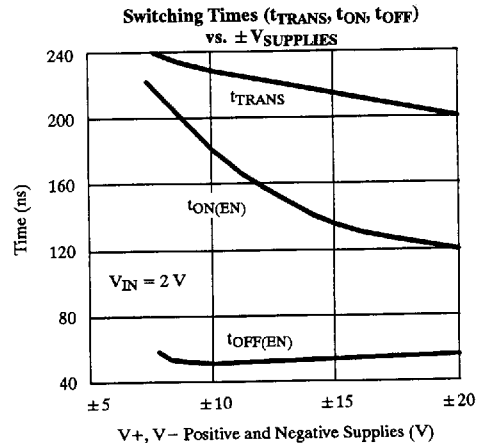
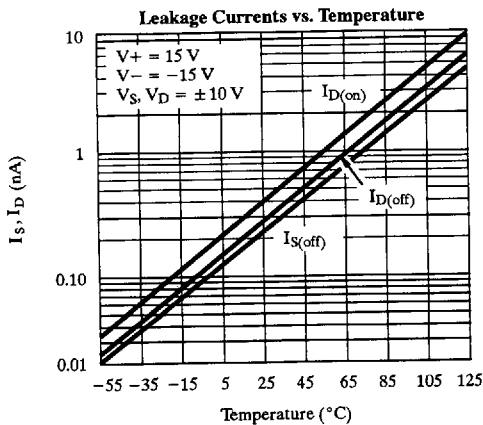
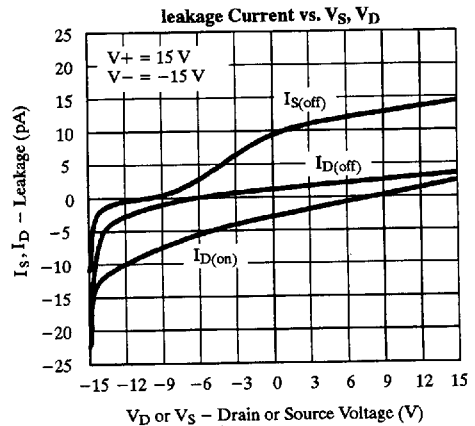
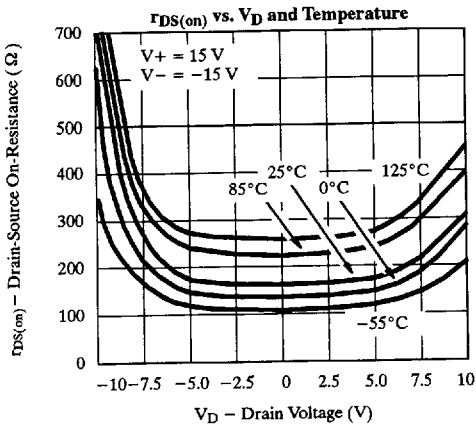
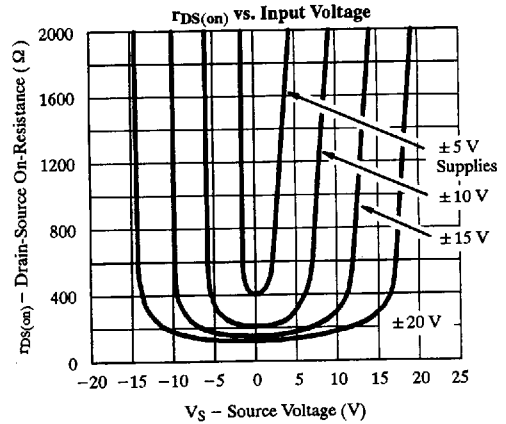
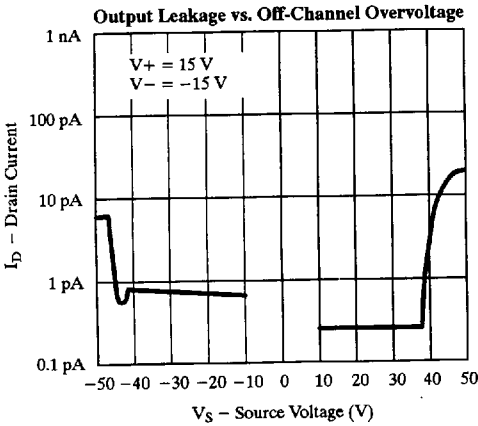

Typical Characteristics (Cont'd)

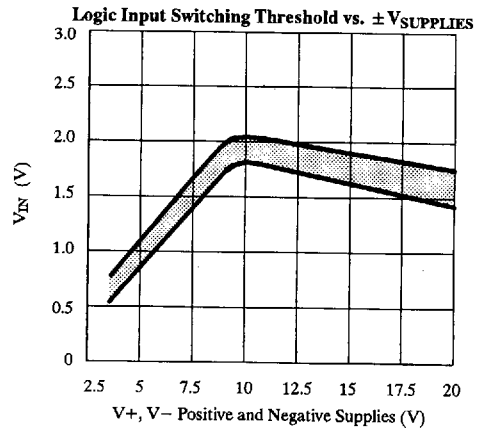
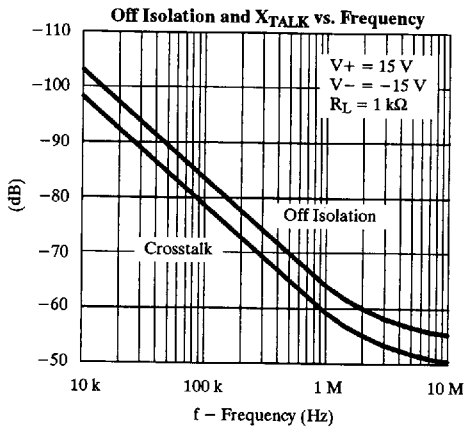
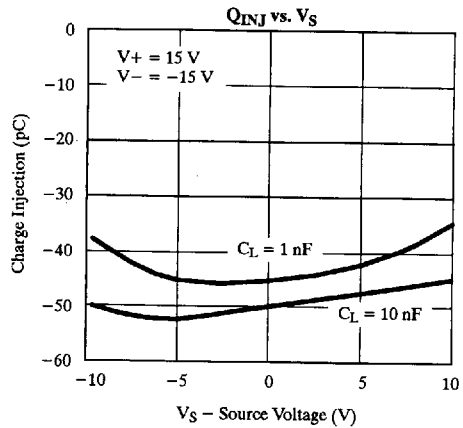
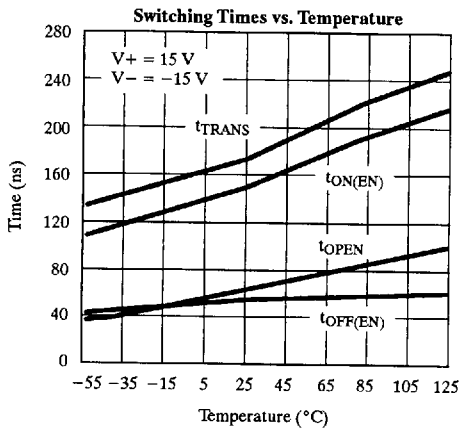

Schematic Diagram (Typical Channel)

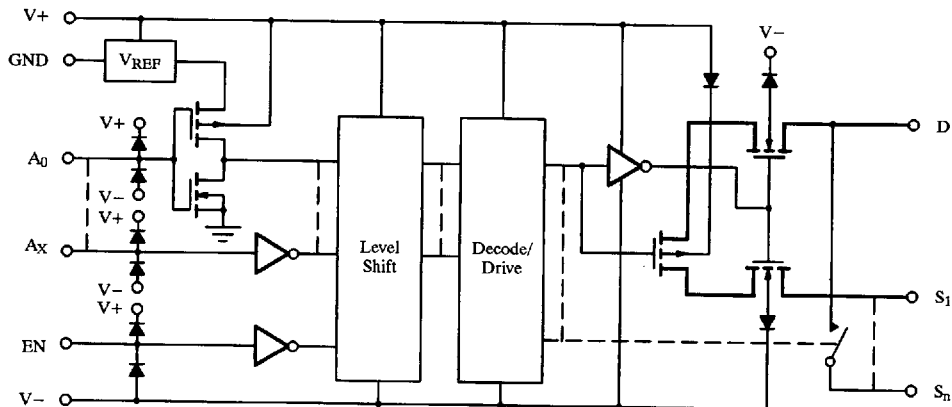

Figure 1.

Test Circuits

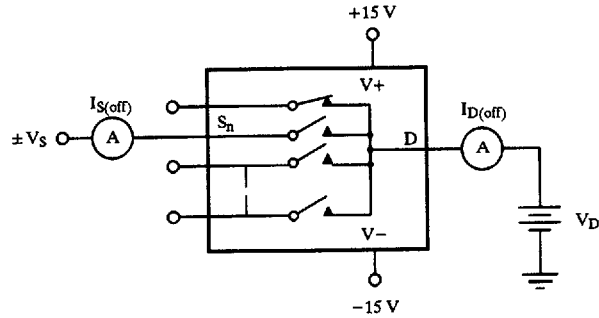
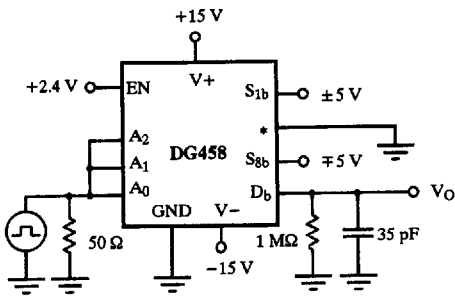

Figure 2. Analog Input Overvoltage



* = $S_{1a} - S_{8a}, S_{2b} - S_{7b}, D_a$

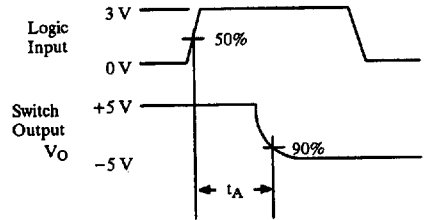

Figure 3. Transition Time

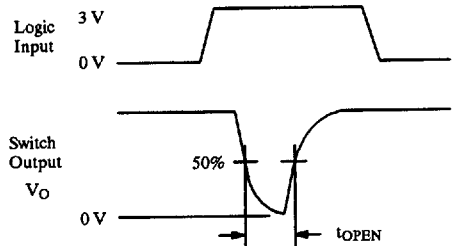
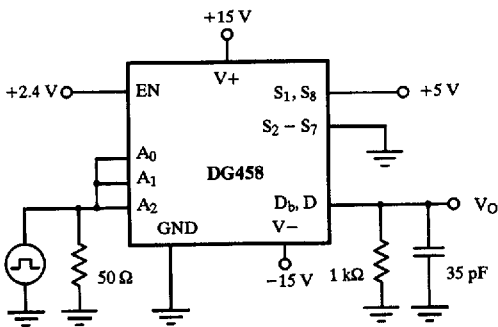

Figure 4. Break-Before-Make Time

Test Circuits (Cont'd)

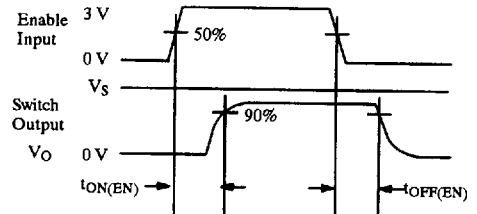
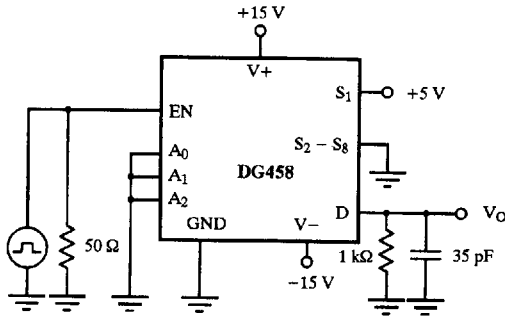

Figure 5. Enable Delay

Detailed Description

The Siliconix DG458 and DG459 multiplexers are fully fault- and overvoltage-protected for continuous input voltages up to ± 35 V whether or not voltage is applied to the power supply pins (V+, V-). These multiplexers are built on a high-voltage junction-isolated silicon-gate CMOS process. Two n-channel and one p-channel MOSFETs are connected in series to form each channel (Figure 17).

Within the normal analog signal range (± 10 V), the $r_{DS(on)}$ variation as a function of analog signal voltage is comparable to that of the classic parallel N-MOS and P-MOS switches.

When the analog signal approaches or exceeds either

supply rail, even for an on-channel, one of the three series MOSFETs gets cut-off, providing inherent protection against overvoltages even if the multiplexer power supply voltages are lost. This protection is good up to the breakdown voltage of the respective series MOSFETs. Under fault conditions only sub microamp leakage currents can flow in or out of the multiplexer. This not only provides protection for the multiplexer and succeeding circuitry, but it allows normal, undisturbed operation of all other channels. Additionally, in case of power loss to the multiplexer, the loading caused on the transducers and signal sources is insignificant, therefore redundant multiplexers can be used on critical applications such as telemetry and avionics.

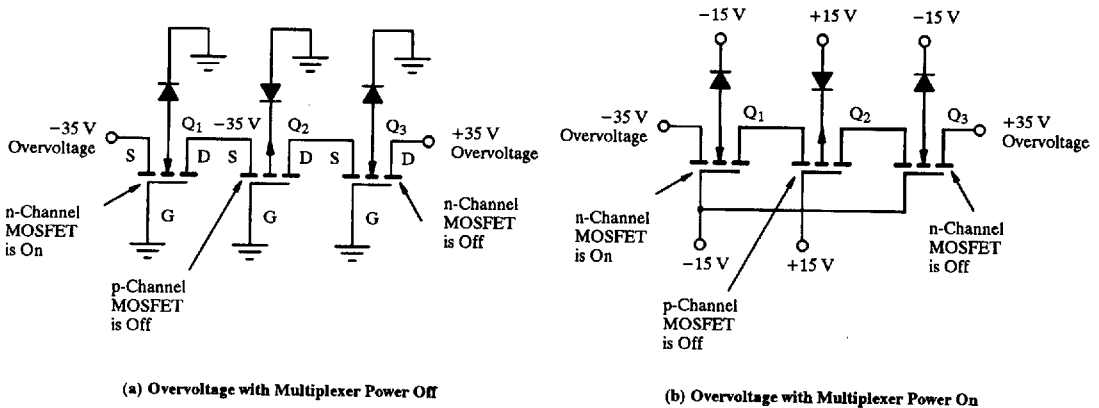

Figure 6. Overvoltage Protection