



U74LVC2G126

CMOS IC

DUAL BUS BUFFER GATE WITH 3-STATE OUTPUTS

DESCRIPTION

The **U74LVC2G126** consists of two bus buffers with 3-state output controlled by enable input (nOE), when nOE is low, the output is disable.

Inputs can be driven from either 3.3V or 5V devices, so the device can be used in a mix 3.3V/5V system.

This device is full specified for partial power-down protective circuit, preventing the backflow current through the device when it is powered down.

FEATURES

- * Operation voltage range: 1.65~5.5V
- * Support 5V Vcc operation
- * Low power dissipation
- * Input accept voltage to 5.5V

ORDERING INFORMATION

Ordering Number			Package	Packing
Normal	Lead Free Plating	Halogen Free		
U74LVC2G126-P08-R	U74LVC2G126L-P08-R	U74LVC2G126G-P08-R	TSSOP-8	Tape Reel
U74LVC2G126-P08-T	U74LVC2G126L-P08-T	U74LVC2G126G-P08-T	TSSOP-8	Tube

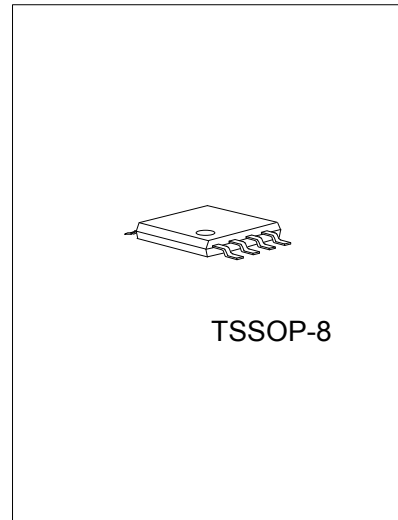

Lead-free: U74LVC2G126L
 Halogen-free : U74LVC2G126G

<p>U74LVC2G126L-P08-R</p> <p>(1)Packing Type (2)Package Type (3)Lead Plating</p>	<p>(1) R: Tape Reel, T: Tube (2) P08: TSSOP-8 (3) G: Halogen Free, L: Lead Free, Blank: Pb/Sn</p>
--	--

■ PIN CONFIGURATION

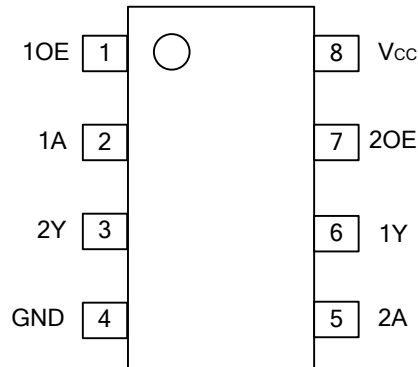

■ FUNCTION TABLE (each gate)

INPUT(nOE)	INPUT(A)	OUTPUT(Y)
H	L	L
H	H	H
L	X	Z

■ LOGIC DIAGRAM (positive logic)

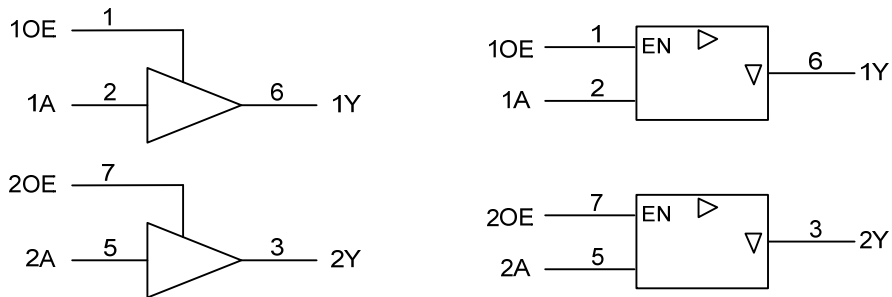

■ ABSOLUTE MAXIMUM RATING (unless otherwise specified)

PARAMETER	SYMBOL	RATINGS	UNIT
Supply Voltage	V_{CC}	-0.5~6.5	V
Input Voltage	V_{IN}	-0.5~6.5	V
Output Voltage	Enable	$-0.5 \sim V_{CC} + 0.5$	V
	Disable	-0.5~6.5	
	Power-down	-0.5~6.5	
V_{CC} or GND Current	I_{CC}	± 100	mA
Input Clamp Current($V_{IN} < 0$)	I_{IK}	-50	mA
Output Clamp Current($V_{OUT} < 0$)	I_{OK}	± 50	mA
Output Current	I_{OUT}	± 50	mA
Power Dissipation	P_D	300	mW
Storage Temperature	T_{STG}	-65 ~ +150	$^{\circ}C$

Note: Absolute maximum ratings are those values beyond which the device could be permanently damaged.
 Absolute maximum ratings are stress ratings only and functional device operation is not implied.

■ RECOMMENDED OPERATING CONDITIONS

PARAMETER	SYMBOL	CONDITIONS	MIN	TYP	MAX	UNIT
Supply Voltage	V_{CC}		1.65		5.5	V
Input Voltage	V_{IN}		0		5.5	V
Output Voltage	Enable	$V_{CC} = 1.65 \sim 5.5V$	0		V_{CC}	V
	Disable	$V_{CC} = 1.65 \sim 5.5V$	0		5.5	V
	Power-down	$V_{CC} = 0V$	0		5.5	V
Input Transition Rise or Fall Rate	t_R, t_F	$V_{CC} = 1.65 \sim 2.7V$	0		20	ns/V
		$V_{CC} = 2.7 \sim 5.5V$	0		10	ns/V
Operating Temperature	T_A		-40		125	$^{\circ}C$

■ STATIC CHARACTERISTICS ($T_A = 25^{\circ}C$)

PARAMETER	SYMBOL	TEST CONDITIONS	MIN	TYP	MAX	UNIT
Positive-Going Input Threshold Voltage	V_{T+}	$V_{CC} = 1.65V \sim 1.95V$	$0.65 \cdot V_{CC}$			V
		$V_{CC} = 2.3V \sim 2.7V$	1.7			
		$V_{CC} = 2.7V \sim 3.6V$	2			
		$V_{CC} = 4.5V \sim 5.5V$	$0.7 \cdot V_{CC}$			
Negative-Going Input Threshold Voltage	V_{T-}	$V_{CC} = 1.65V \sim 1.95V$			$0.35 \cdot V_{CC}$	V
		$V_{CC} = 2.3V \sim 2.7V$			0.7	
		$V_{CC} = 2.7V \sim 3.6V$			0.8	
		$V_{CC} = 4.5V \sim 5.5V$			$0.3 \cdot V_{CC}$	
High-Level Output Voltage	V_{OH}	$V_{CC} = 1.65V \sim 5.5V, I_{OH} = -100\mu A$	$V_{CC} - 0.1$			V
		$V_{CC} = 1.65V, I_{OH} = -4mA$	1.2			
		$V_{CC} = 2.3V, I_{OH} = -8mA$	1.9			
		$V_{CC} = 2.7V, I_{OH} = -12mA$	2.2			
		$V_{CC} = 3V, I_{OH} = -24mA$	2.3			
		$V_{CC} = 4.5V, I_{OH} = -32mA$	3.8			
Low-Level Output Voltage	V_{OL}	$V_{CC} = 1.65V \sim 5.5V, I_{OL} = 100\mu A$			0.1	V
		$V_{CC} = 1.65V, I_{OL} = 4mA$			0.45	
		$V_{CC} = 2.3V, I_{OL} = 8mA$			0.3	
		$V_{CC} = 2.7V, I_{OL} = 12mA$			0.4	
		$V_{CC} = 3V, I_{OL} = 24mA$			0.55	
		$V_{CC} = 4.5V, I_{OL} = 32mA$			0.55	
Input Leakage Current	$I_{I(LEAK)}$	$V_{CC} = 5.5V, V_{IN} = 5.5V$ or GND		± 0.1	± 5	μA
Output OFF -State Current	I_{OZ}	$V_{CC} = 3.6V, V_{OUT} = V_{CC}$ or GND		± 0.1	± 10	μA
Power OFF Leakage Current	I_{OFF}	$V_{CC} = 0V, V_{IN}$ or $V_{OUT} = 5.5V$		± 0.1	± 10	

■ STATIC CHARACTERISTICS(Cont.)

PARAMETER	SYMBOL	TEST CONDITIONS	MIN	TYP	MAX	UNIT
Quiescent Supply Current	I_Q	$V_{CC}=5.5V$, $V_{IN}=V_{CC}$ or GND $I_{OUT}=0$		0.1	10	μA
Additional Quiescent Supply Current	ΔI_Q	$V_{CC}=2.3V\sim 5.5V$, One input at $V_{CC}-0.6V$, other inputs at V_{CC} or GND		5	500	μA
Input Capacitance	C_{IN}	$V_{IN}=V_{CC}$ or GND		2		pF

■ DYNAMIC CHARACTERISTICS

PARAMETER	SYMBOL	TEST CONDITIONS	MIN	TYP	MAX	UNIT
Propagation Delay From Input(A) to Output(Y)	t_{PHL}/t_{PLH}	$V_{CC}=1.8V\pm 0.15V$	1	3.9	9.8	ns
		$V_{CC}=2.5V\pm 0.2V$	0.5	2.6	4.9	
		$V_{CC}=2.7V$	1	2.8	4.7	
		$V_{CC}=3.3V\pm 0.3V$	0.5	2.4	4.3	
		$V_{CC}=5.0V\pm 0.5V$	0.5	1.9	3.2	
Propagation Delay From Input(nOE) to Output(Y)	t_{PZH}/t_{PZL}	$V_{CC}=1.8V\pm 0.15V$	1.0	4.1	10	ns
		$V_{CC}=2.5V\pm 0.2V$	1.0	2.6	5	
		$V_{CC}=2.7V$	1.0	2.8	4.7	
		$V_{CC}=3.3V\pm 0.3V$	1.0	2.4	4.1	
		$V_{CC}=5.0V\pm 0.5V$	0.5	1.8	3.1	
Propagation Delay From Input(nOE) to Output(Y)	t_{PZL}/t_{PZH}	$V_{CC}=1.8V\pm 0.15V$	1	3.3	12.6	ns
		$V_{CC}=2.5V\pm 0.2V$	0.5	1.9	5.7	
		$V_{CC}=2.7V$	1	3.0	4.8	
		$V_{CC}=3.3V\pm 0.3V$	1	2.5	4.4	
		$V_{CC}=5.0V\pm 0.5V$	0.5	1.8	3.3	

■ OPERATING CHARACTERISTICS ($T_A=25^\circ C$)

PARAMETER	SYMBOL	TEST CONDITIONS	MIN	TYP	MAX	UNIT
Power Dissipation Capacitance	Cpd	Output Enable		17		pF
		Output Disable		5		

TEST CIRCUIT AND WAVEFORMS

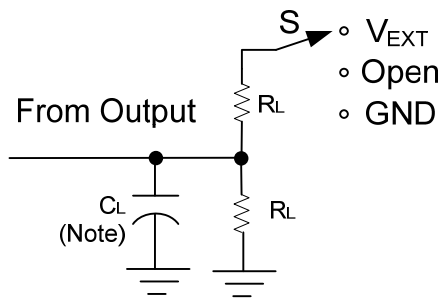

TEST	S
t_{PLH}/t_{PHL}	Open
t_{PHZ}/t_{PZH}	GND
t_{PLZ}/t_{PZL}	V_{EXT}

Note : C_L includes probe and jig capacitance.

V_{CC}	V_{IN}	t_R, t_F	V_M	V_{EXT}	C_L	R_L	V_{Δ}
$1.8V \pm 0.15V$	V_{CC}	$\leq 2ns$	$V_{CC}/2$	$2 * V_{CC}$	30pF	1K Ω	0.15V
$2.5V \pm 0.2V$	V_{CC}	$\leq 2ns$	$V_{CC}/2$	$2 * V_{CC}$	30pF	500 Ω	0.15V
2.7V	2.7V	$\leq 2.5ns$	1.5V	6V	50pF	500 Ω	0.3V
$3.3V \pm 0.3V$	2.7 V	$\leq 2.5ns$	1.5V	6V	50pF	500 Ω	0.3V
$5V \pm 0.5V$	V_{CC}	$\leq 2.5ns$	$V_{CC}/2$	$2 * V_{CC}$	50pF	500 Ω	0.3V

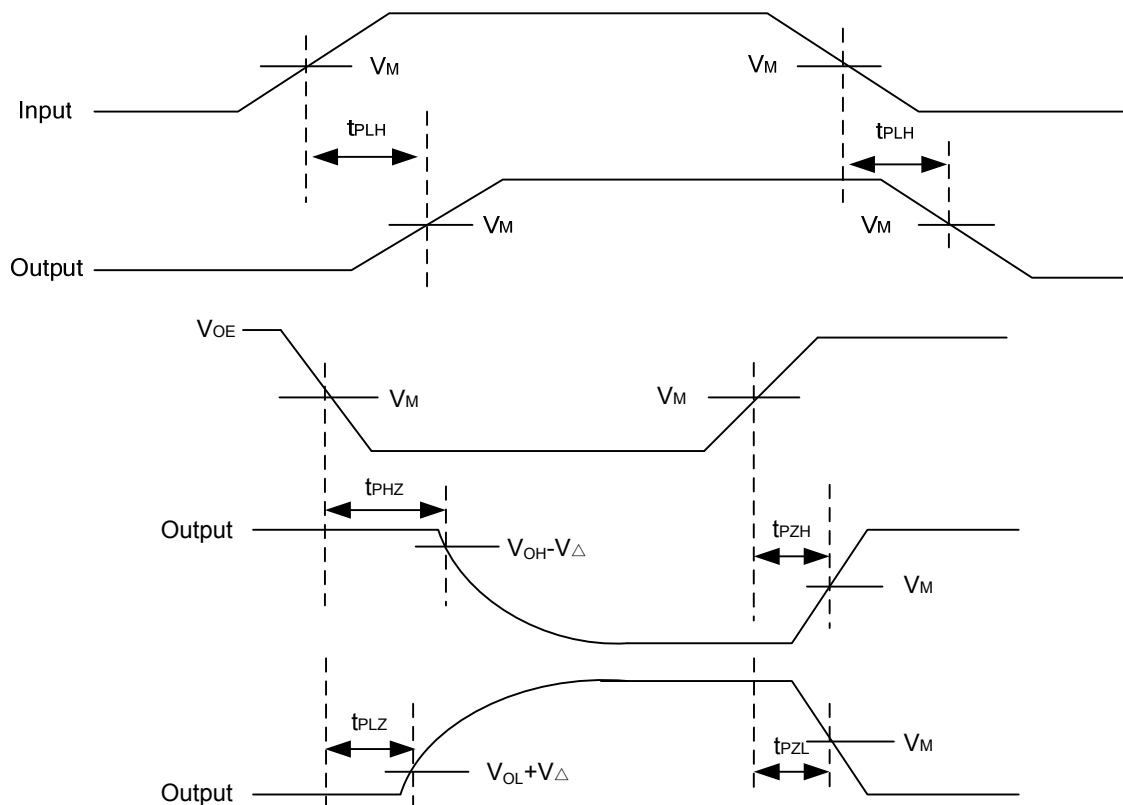

UTC assumes no responsibility for equipment failures that result from using products at values that exceed, even momentarily, rated values (such as maximum ratings, operating condition ranges, or other parameters) listed in products specifications of any and all UTC products described or contained herein. UTC products are not designed for use in life support appliances, devices or systems where malfunction of these products can be reasonably expected to result in personal injury. Reproduction in whole or in part is prohibited without the prior written consent of the copyright owner. The information presented in this document does not form part of any quotation or contract, is believed to be accurate and reliable and may be changed without notice.