

SN74ALS841, SN74AS841A, SN74ALS842 10-BIT BUS-INTERFACE D-TYPE LATCHES WITH 3-STATE OUTPUTS

SDAS059C – DECEMBER 1983 – REVISED JANUARY 1995

- 3-State Buffer-Type Outputs Drive Bus Lines Directly
- Bus-Structured Pinout
- Provide Extra Bus-Driving Latches Necessary for Wider Address/Data Paths or Buses With Parity
- Buffered Control Inputs to Reduce dc Loading Effects
- Power-Up High-Impedance State
- Package Options Include Plastic Small-Outline (DW) Packages and Standard Plastic (NT) 300-mil DIPs

description

These 10-bit latches feature 3-state outputs designed specifically for driving highly capacitive or relatively low-impedance loads. They are particularly suitable for implementing buffer registers, I/O ports, bidirectional bus drivers, and working registers.

The ten latches are transparent D-type latches. The SN74ALS841 and SN74AS841A have noninverting data (D) inputs. The SN74ALS842 has inverting \bar{D} inputs.

A buffered output-enable (\overline{OE}) input places the ten outputs in either a normal logic state (high or low logic levels) or a high-impedance state. In the high-impedance state, the outputs neither load nor drive the bus lines significantly. The high-impedance state and increased drive provide the capability to drive bus lines without interface or pullup components.

\overline{OE} does not affect the internal operation of the latches. Previously stored data can be retained or new data can be entered while the outputs are off.

The SN74ALS841, SN74AS841A, and SN74ALS842 are characterized for operation from 0°C to 70°C.

SN74ALS841, SN74AS841A . . . DW OR NT PACKAGE
(TOP VIEW)

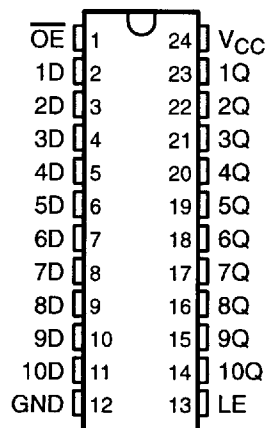

SN74ALS842 . . . DW OR NT PACKAGE
(TOP VIEW)

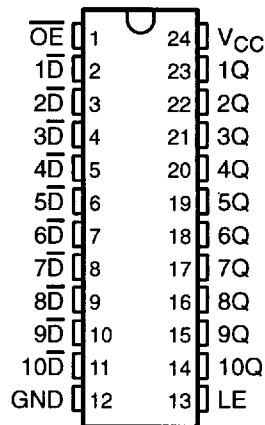

SN74ALS841, SN74AS841A, SN74ALS842 10-BIT BUS-INTERFACE D-TYPE LATCHES WITH 3-STATE OUTPUTS

SDAS059C – DECEMBER 1983 – REVISED JANUARY 1995

Function Tables

SN74ALS841, SN74AS841A

INPUTS			OUTPUT Q
\overline{OE}	LE	D	
L	H	H	H
L	H	L	L
L	L	X	Q_0
H	X	X	Z

SN74ALS842

INPUTS			OUTPUT Q
\overline{OE}	LE	\overline{D}	
L	H	H	L
L	H	L	H
L	L	X	Q_0
H	X	X	Z

logic symbols†

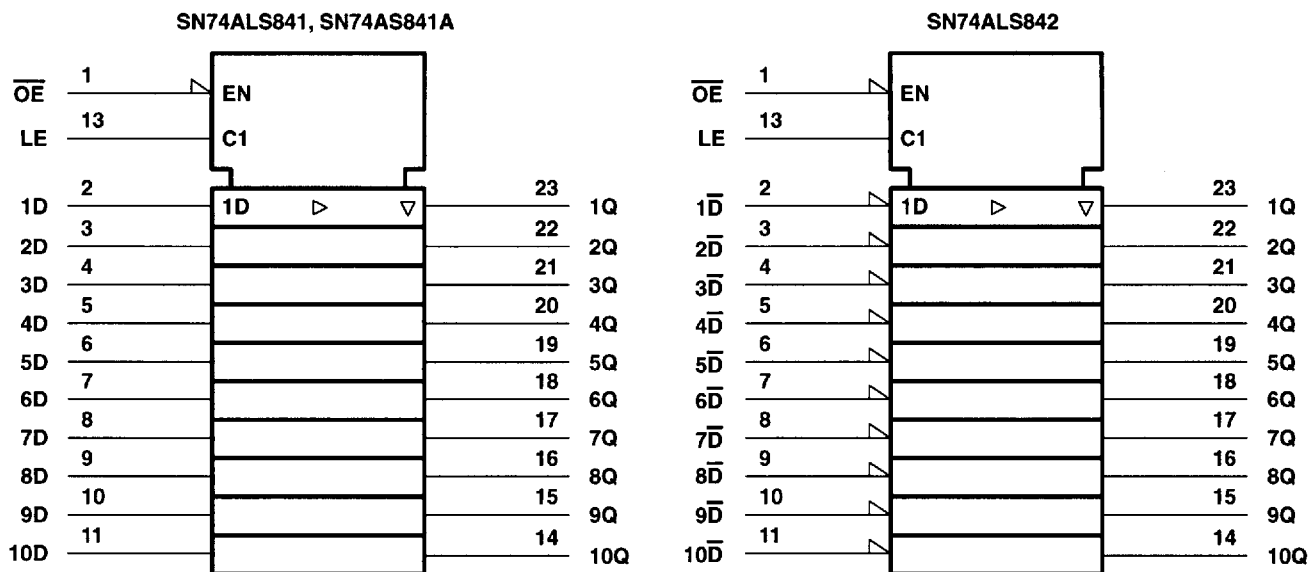

† These symbols are in accordance with ANSI/IEEE Std 91-1984 and IEC Publication 617-12.

SN74ALS841, SN74AS841A, SN74ALS842 10-BIT BUS-INTERFACE D-TYPE LATCHES WITH 3-STATE OUTPUTS

SDAS059C - DECEMBER 1983 - REVISED JANUARY 1995

logic diagrams (positive logic)

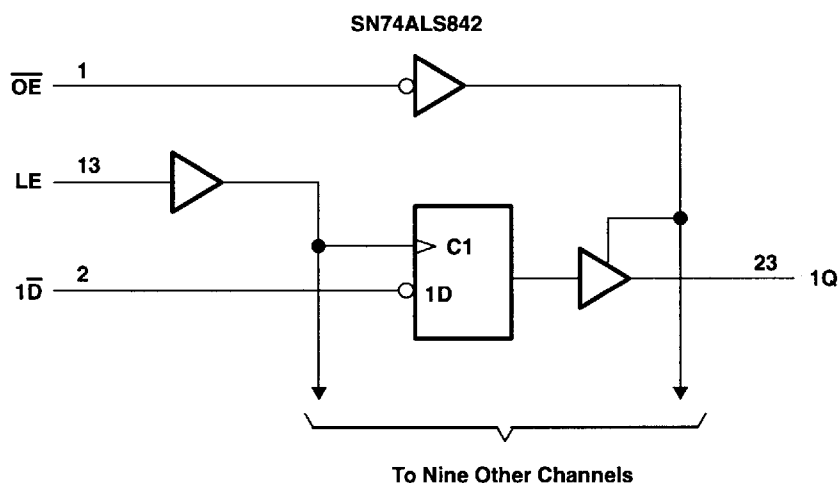
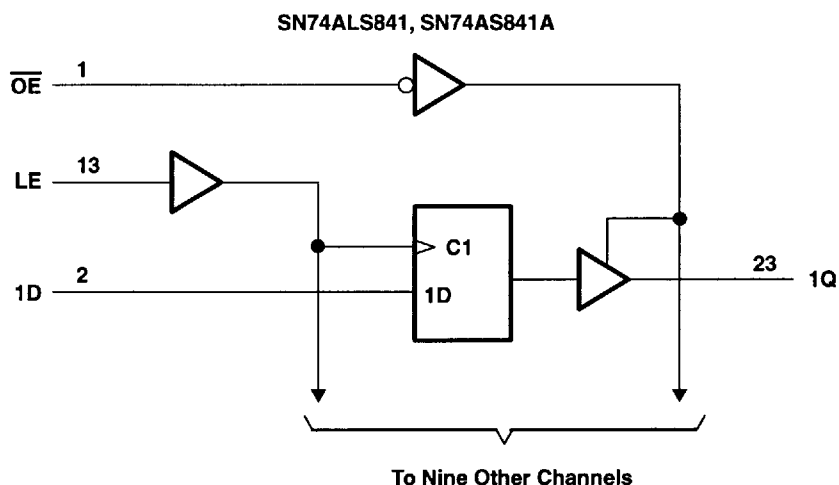

absolute maximum ratings over operating free-air temperature range (unless otherwise noted)†

Supply voltage, V_{CC}	7 V
Input voltage, V_I	7 V
Voltage applied to a disabled 3-state output	5.5 V
Operating free-air temperature range, T_A : SN74ALS841, SN74ALS842	0°C to 70°C
Storage temperature range	-65°C to 150°C

† Stresses beyond those listed under "absolute maximum ratings" may cause permanent damage to the device. These are stress ratings only, and functional operation of the device at these or any other conditions beyond those indicated under "recommended operating conditions" is not implied. Exposure to absolute-maximum-rated conditions for extended periods may affect device reliability.



POST OFFICE BOX 655303 • DALLAS, TEXAS 75265

SN74ALS841, SN74AS841A, SN74ALS842 10-BIT BUS-INTERFACE D-TYPE LATCHES WITH 3-STATE OUTPUTS

SDAS059C – DECEMBER 1983 – REVISED JANUARY 1995

recommended operating conditions

		SN74ALS841 SN74ALS842			UNIT
		MIN	NOM	MAX	
V _{CC}	Supply voltage	4.5	5	5.5	V
V _{IH}	High-level input voltage	2			V
V _{IL}	Low-level input voltage			0.8	V
I _{OH}	High-level output current			-2.6	mA
I _{OL}	Low-level output current			24	mA
t _w	Pulse duration, LE high	20			ns
t _{su}	Setup time, data before LE↓	10			ns
t _h	Hold time, data after LE↓	5			ns
T _A	Operating free-air temperature	0		70	°C

electrical characteristics over recommended operating free-air temperature range (unless otherwise noted)

PARAMETER	TEST CONDITIONS	SN74ALS841 SN74ALS842		UNIT		
		MIN	TYP†		MAX	
V _{IK}	V _{CC} = 4.5 V, I _I = -18 mA			-1.2	V	
V _{OH}	V _{CC} = 4.5 V to 5.5 V, I _{OH} = -0.4 mA	V _{CC} - 2			V	
	V _{CC} = 4.5 V, I _{OH} = -2.6 mA	2.4	3.2			
V _{OL}	V _{CC} = 4.5 V	I _{OL} = 12 mA		0.25	0.4	
		I _{OL} = 24 mA		0.35	0.5	
I _{OZH}	V _{CC} = 5.5 V, V _O = 2.7 V			20	μA	
I _{OZL}	V _{CC} = 5.5 V, V _O = 0.4 V			-20	μA	
I _I	V _{CC} = 5.5 V, V _I = 7 V			0.1	mA	
I _{IH}	V _{CC} = 5.5 V, V _I = 2.7 V			20	μA	
I _{IL}	V _{CC} = 5.5 V, V _I = 0.4 V			-0.1	mA	
I _{O‡}	V _{CC} = 5.5 V, V _O = 2.25 V	-30		-112	mA	
I _{CC}	SN74ALS841	V _{CC} = 5.5 V	Outputs high	19	30	mA
			Outputs low	38	62	
			Outputs disabled	23	40	
	SN74ALS842	V _{CC} = 5.5 V	Outputs high	20	35	
			Outputs low	48	74	
			Outputs disabled	27	44	

† All typical values are at V_{CC} = 5 V, T_A = 25°C.

‡ The output conditions have been chosen to produce a current that closely approximates one half of the true short-circuit output current, I_{OS}.



POST OFFICE BOX 655303 • DALLAS, TEXAS 75265

SN74ALS841, SN74AS841A, SN74ALS842 10-BIT BUS-INTERFACE D-TYPE LATCHES WITH 3-STATE OUTPUTS

SDAS059C – DECEMBER 1983 – REVISED JANUARY 1995

switching characteristics (see Figure 1)

PARAMETER	FROM (INPUT)	TO (OUTPUT)	V _{CC} = 4.5 V to 5.5 V, C _L = 50 pF, R ₁ = 500 Ω, R ₂ = 500 Ω, T _A = MIN to MAX†		UNIT
			SN74ALS841		
			MIN	MAX	
t _{PLH}	D	Q	2	13	ns
t _{PHL}			2	13	
t _{PLH}	LE	Q	7	21	ns
t _{PHL}			8	26	
t _{PZH}	\overline{OE}	Q	2	12	ns
t _{PZL}			2	12	
t _{PHZ}	\overline{OE}	Q	2	10	ns
t _{PLZ}			2	12	

† For conditions shown as MIN or MAX, use the appropriate value specified under recommended operating conditions.

switching characteristics (see Figure 1)

PARAMETER	FROM (INPUT)	TO (OUTPUT)	V _{CC} = 4.5 V to 5.5 V, C _L = 50 pF, R ₁ = 500 Ω, R ₂ = 500 Ω, T _A = MIN to MAX†		UNIT
			SN74ALS842		
			MIN	MAX	
t _{PLH}	\overline{D}	Q	4	18	ns
t _{PHL}			3	13	
t _{PLH}	LE	Q	8	27	ns
t _{PHL}			6	20	
t _{PZH}	\overline{OE}	Q	2	12	ns
t _{PZL}			2	12	
t _{PHZ}	\overline{OE}	Q	1	10	ns
t _{PLZ}			2	12	

† For conditions shown as MIN or MAX, use the appropriate value specified under recommended operating conditions.

absolute maximum ratings over operating free-air temperature range (unless otherwise noted) ‡

Supply voltage, V _{CC}	7 V
Input voltage, V _I	7 V
Voltage applied to a disabled 3-state output	5.5 V
Operating free-air temperature range, T _A : SN74AS841A	0°C to 70°C
Storage temperature range	-65°C to 150°C

‡ Stresses beyond those listed under "absolute maximum ratings" may cause permanent damage to the device. These are stress ratings only, and functional operation of the device at these or any other conditions beyond those indicated under "recommended operating conditions" is not implied. Exposure to absolute-maximum-rated conditions for extended periods may affect device reliability.



POST OFFICE BOX 655303 • DALLAS, TEXAS 75265

SN74ALS841, SN74AS841A, SN74ALS842
10-BIT BUS-INTERFACE D-TYPE LATCHES
WITH 3-STATE OUTPUTS

SDAS059C – DECEMBER 1983 – REVISED JANUARY 1995

recommended operating conditions

		SN74AS841A			UNIT
		MIN	NOM	MAX	
V _{CC}	Supply voltage	4.5	5	5.5	V
V _{IH}	High-level input voltage	2			V
V _{IL}	Low-level input voltage			0.8	V
I _{OH}	High-level output current			-24	mA
I _{OL}	Low-level output current			48	mA
t _w	Pulse duration, LE high	4			ns
t _{su}	Setup time, data before LE↓	2.5			ns
t _h	Hold time, data after LE↓	2.5			ns
T _A	Operating free-air temperature	0		70	°C

electrical characteristics over recommended operating free-air temperature range (unless otherwise noted)

PARAMETER	TEST CONDITIONS	SN74AS841A		UNIT		
		MIN	TYP†		MAX	
V _{IK}	V _{CC} = 4.5 V, I _I = -18 mA			-1.2	V	
V _{OH}	V _{CC} = 4.5 V to 5.5 V, I _{OH} = -2 mA	V _{CC} - 2		V		
	V _{CC} = 4.5 V, I _{OH} = -15 mA	2.4	3.2			
	V _{CC} = 4.5 V, I _{OH} = -24 mA	2				
V _{OL}	V _{CC} = 4.5 V, I _{OL} = 48 mA	0.35	0.5	V		
I _{OZH}	V _{CC} = 5.5 V, V _O = 2.7 V			50	μA	
I _{OZL}	V _{CC} = 5.5 V, V _O = 0.4 V			-50	μA	
I _I	V _{CC} = 5.5 V, V _I = 7 V			0.1	mA	
I _{IH}	V _{CC} = 5.5 V, V _I = 2.7 V			20	μA	
I _{IL}	V _{CC} = 5.5 V, V _I = 0.4 V			-0.5	mA	
I _{O‡}	V _{CC} = 5.5 V, V _O = 2.25 V	-30		-112	mA	
I _{CC}	V _{CC} = 5.5 V	Outputs high		36	60	mA
		Outputs low		58	94	
		Outputs disabled		56	93	

† All typical values are at V_{CC} = 5 V, T_A = 25°C.

‡ The output conditions have been chosen to produce a current that closely approximates one half of the true short-circuit output current, I_{OS}.



POST OFFICE BOX 655303 • DALLAS, TEXAS 75265

SN74ALS841, SN74AS841A, SN74ALS842
10-BIT BUS-INTERFACE D-TYPE LATCHES
WITH 3-STATE OUTPUTS

SDAS059C – DECEMBER 1983 – REVISED JANUARY 1995

switching characteristics (see Figure 1)

PARAMETER	FROM (INPUT)	TO (OUTPUT)	V _{CC} = 4.5 V to 5.5 V, C _L = 50 pF, R ₁ = 500 Ω, R ₂ = 500 Ω, T _A = MIN to MAX†		UNIT
			SN74AS841A		
			MIN	MAX	
t _{PLH}	D	Q	1	6.5	ns
t _{PHL}			1	10.5	
t _{PLH}	LE	Q	2	12	ns
t _{PHL}			2	12	
t _{PZH}	\overline{OE}	Q	2	14	ns
t _{PZL}			2	16	
t _{PHZ}	\overline{OE}	Q	1	8	ns
t _{PLZ}			1	8	

† For conditions shown as MIN or MAX, use the appropriate value specified under recommended operating conditions.



POST OFFICE BOX 655303 • DALLAS, TEXAS 75265

SN74ALS841, SN74AS841A, SN74ALS842 10-BIT BUS-INTERFACE D-TYPE LATCHES WITH 3-STATE OUTPUTS

SDAS059C - DECEMBER 1983 - REVISED JANUARY 1995

PARAMETER MEASUREMENT INFORMATION SERIES 54ALS/74ALS AND 54AS/74AS DEVICES

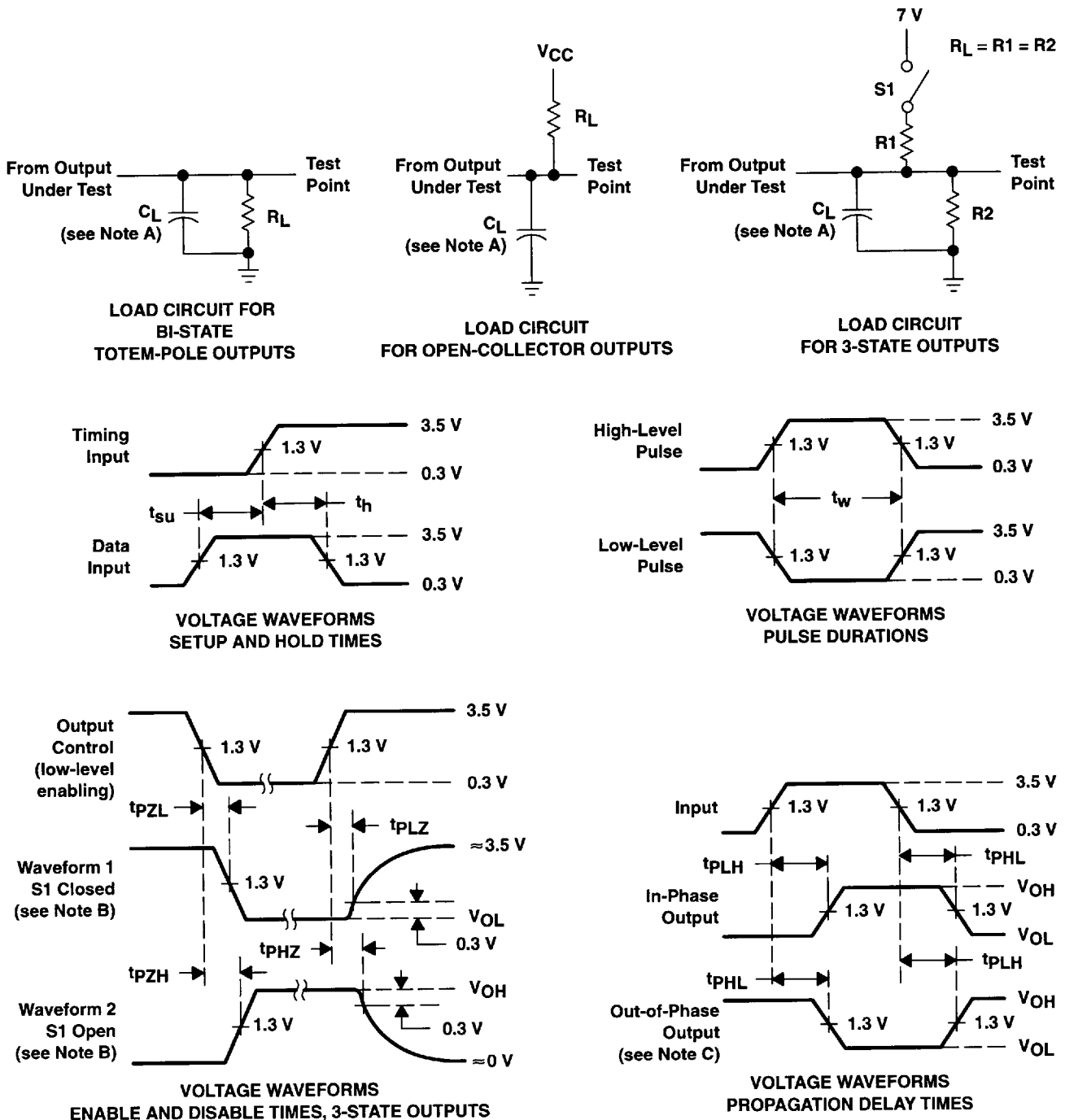

- NOTES: A. C_L includes probe and jig capacitance.
 B. Waveform 1 is for an output with internal conditions such that the output is low except when disabled by the output control. Waveform 2 is for an output with internal conditions such that the output is high except when disabled by the output control.
 C. When measuring propagation delay items of 3-state outputs, switch S1 is open.
 D. All input pulses have the following characteristics: $PRR \leq 1$ MHz, $t_r = t_f = 2$ ns, duty cycle = 50%.
 E. The outputs are measured one at a time with one transition per measurement.

Figure 1. Load Circuits and Voltage Waveforms

**TEXAS
INSTRUMENTS**

POST OFFICE BOX 655303 • DALLAS, TEXAS 75265