

ROHS Compliant



台灣駿品端子股份有限公司

TAIWAN KING PIN TERMINAL CO.,LTD

台北縣樹林市俊德街 23 號

TEL:886-2-26895596.26886112

FAX:886-2-26886110

E-mail:info@tkp.com.tw

http://www.tkp.com.tw

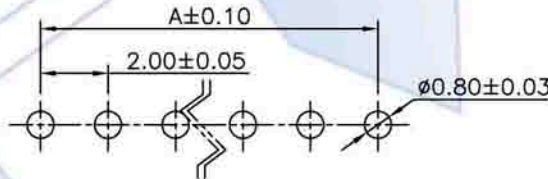
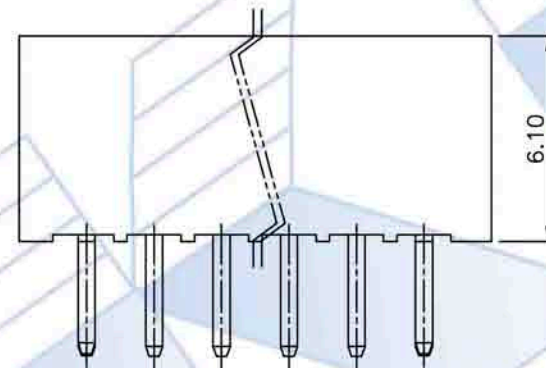
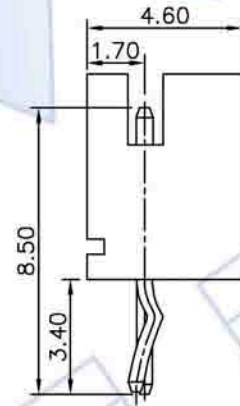
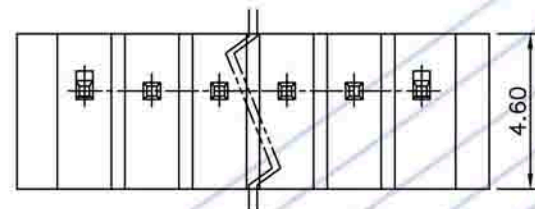
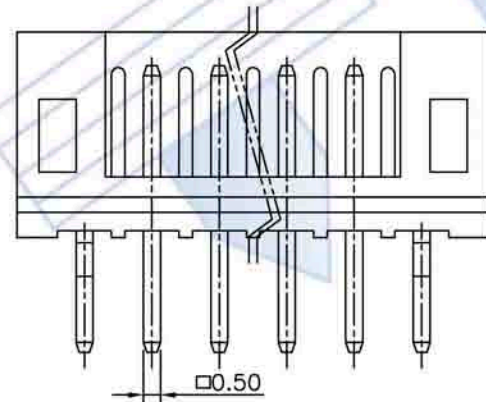
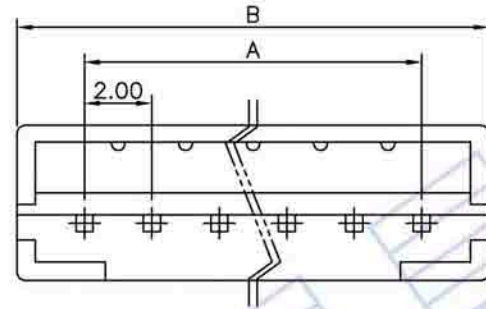

RECOMMENDED PCB LAYOUT

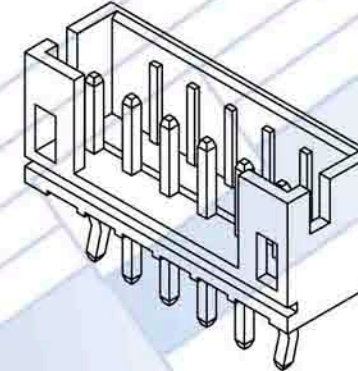

NOTE :

- * Material : Nylon UL 94V-0
- * Contact : Brass
- * Finish : Plated Tin/ over Nickel
- * Electrical rating : UL 125V 1A, AC/DC
CSA 250V 1A, AC/DC
- * Standard color: White or Black
- * .020" (0.5mm) straight square pins
- * Mates with H110 series housings
- * 2-16 circuits available



Circuits	Part No.	Dim. A	Dim. B	Circuits	Part No.	Dim. A	Dim. B
2	P110I-02	2.00	6.00	9	P110I-09	16.00	20.00
3	P110I-03	4.00	8.00	10	P110I-10	18.00	22.00
4	P110I-04	6.00	10.00	11	P110I-11	20.00	24.00
5	P110I-05	8.00	12.00	12	P110I-12	22.00	26.00
6	P110I-06	10.00	14.00	13	P110I-13	24.00	28.00
7	P110I-07	12.00	16.00	14	P110I-14	26.00	30.00
8	P110I-08	14.00	18.00	15	P110I-15	28.00	32.00



PART NO.	P110I-XX			Part NO.	Material	Color/Finish	Remark	APPROVAL
TITLE	2.00mm Wire to Board			P110I-XX	Nylon UL 94V-0	White		DRAWN: 高琇瑩
THIRD ANGLE	SCALE	UNIT	SHEET NO	P110I-XXA	Nylon UL 94V-0 (旭化成)	White		CHECKED: 張明遠
	2.5:1	mm	1/1	P110I-XXB	Nylon UL 94V-0	Black		APPROVED: 陳泓宇
				TOLERANCE	DATE	ODD NUMBERS	REV	
				.X± 0.30 .XXX±0.10	2011.12.28	ENG951263	A4	
				.XX± 0.20 ANGLE±2°				