

**APT5020BNR 500V 28.0A 0.20Ω**

**APT5022BNR 500V 27.0A 0.22Ω**

**POWER MOS IV®**

**UIS RATED**

**N-CHANNEL ENHANCEMENT MODE HIGH VOLTAGE POWER MOSFETS**

**MAXIMUM RATINGS**

All Ratings:  $T_C = 25^\circ\text{C}$  unless otherwise specified.

Symbol	Parameter	APT5020BNR	APT5022BNR	UNIT
$V_{DSS}$	Drain-Source Voltage	500	500	Volts
$I_D$	Continuous Drain Current @ $T_C = 25^\circ\text{C}$	28	27	Amps
$I_{DM}$	Pulsed Drain Current <sup>①</sup>	112	108	
$V_{GS}$	Gate-Source Voltage Continuous	±20		Volts
$V_{GSM}$	Gate-Source Voltage Transient	±30		
$P_D$	Total Power Dissipation @ $T_C = 25^\circ\text{C}$	360		Watts
	Linear Derating Factor	2.9		W/°C
$T_J, T_{STG}$	Operating and Storage Junction Temperature Range	-55 to 150		°C
$T_L$	Lead Temperature: 0.063" from Case for 10 Sec.	300		
$I_{AR}$	Avalanche Current <sup>①</sup> (Repetitive and Non-Repetitive)	28		Amps
$E_{AR}$	Repetitive Avalanche Energy <sup>①</sup>	30		mJ
$E_{AS}$	Single Pulse Avalanche Energy <sup>④</sup>	1300		

**STATIC ELECTRICAL CHARACTERISTICS**

Symbol	Characteristic / Test Conditions	MIN	TYP	MAX	UNIT
$BV_{DSS}$	Drain-Source Breakdown Voltage ( $V_{GS} = 0V, I_D = 250 \mu\text{A}$ )	500			Volts
$I_{D(ON)}$	On State Drain Current <sup>②</sup> ( $V_{DS} > I_{D(ON)} \times R_{DS(ON)}$ Max, $V_{GS} = 10V$ )	APT5020BNR	28		Amps
		APT5022BNR	27		
$R_{DS(ON)}$	Drain-Source On-State Resistance <sup>②</sup> ( $V_{GS} = 10V, 0.5 I_D$ [Cont.])	APT5020BNR		0.20	Ohms
		APT5022BNR		0.22	
$I_{DSS}$	Zero Gate Voltage Drain Current ( $V_{DS} = V_{DSS}, V_{GS} = 0V$ )			250	$\mu\text{A}$
	Zero Gate Voltage Drain Current ( $V_{DS} = 0.8 V_{DSS}, V_{GS} = 0V, T_C = 125^\circ\text{C}$ )			1000	
$I_{GSS}$	Gate-Source Leakage Current ( $V_{GS} = \pm 20V, V_{DS} = 0V$ )			±100	nA
$V_{GS(TH)}$	Gate Threshold Voltage ( $V_{DS} = V_{GS}, I_D = 1.0\text{mA}$ )	2		4	Volts

**THERMAL CHARACTERISTICS**

Symbol	Characteristic	MIN	TYP	MAX	UNIT
$R_{\theta JC}$	Junction to Case			0.34	°C/W
$R_{\theta JA}$	Junction to Ambient			40	

**CAUTION:** These Devices are Sensitive to Electrostatic Discharge. Proper Handling Procedures Should Be Followed.

**405 S.W. COLUMBIA STREET  
BEND, OREGON 97702-1035  
U.S.A.**

**PHONE . . . (503) 382-8028**

**FAX . . . . . (503) 388-0364**

**DYNAMIC CHARACTERISTICS**

**APT5020/5022BNR**

Symbol	Characteristic	Test Conditions	MIN	TYP	MAX	UNIT
$C_{iss}$	Input Capacitance	$V_{GS} = 0V$		3610		pF
$C_{oss}$	Output Capacitance	$V_{DS} = 25V$		602		
$C_{rss}$	Reverse Transfer Capacitance	$f = 1\text{ MHz}$		248		
$Q_g$	Total Gate Charge ③	$V_{GS} = 10V$		182		nC
$Q_{gs}$	Gate-Source Charge	$V_{DD} = 0.5 V_{DSS}$		20		
$Q_{gd}$	Gate-Drain ("Miller") Charge	$I_D = I_D [\text{Cont.}] @ 25^\circ\text{C}$		105		
$t_{d(on)}$	Turn-on Delay Time	$V_{GS} = 15V$		21		ns
$t_r$	Rise Time	$V_{DD} = 0.5 V_{DSS}$		43		
$t_{d(off)}$	Turn-off Delay Time	$I_D = I_D [\text{Cont.}] @ 25^\circ\text{C}$		119		
$t_f$	Fall Time	$R_G = 1.8\Omega$		64		

**SOURCE-DRAIN DIODE RATINGS AND CHARACTERISTICS**

Symbol	Characteristic / Test Conditions	MIN	TYP	MAX	UNIT
$I_S$	Continuous Source Current (Body Diode)	APT5020BNR		28	Amps
		APT5022BNR		27	
$I_{SM}$	Pulsed Source Current ① (Body Diode)	APT5020BNR		112	Amps
		APT5022BNR		108	
$V_{SD}$	Diode Forward Voltage ② ( $V_{GS} = 0V, I_S = -I_D [\text{Cont.}]$ )			1.3	Volts
$t_{rr}$	Reverse Recovery Time ( $I_S = -I_D [\text{Cont.}], dI_S/dt = 100A/\mu s$ )	215	430	860	ns
$Q_{rr}$	Reverse Recovery Charge ( $I_S = -I_D [\text{Cont.}], dI_S/dt = 100A/\mu s$ )	3	7	14	$\mu C$

**SAFE OPERATING AREA CHARACTERISTICS**

Symbol	Characteristic	Test Conditions	MIN	TYP	MAX	UNIT
SOA1	Safe Operating Area	$V_{DS} = 0.4 V_{DSS}, I_{DS} = P_D / 0.4 V_{DSS}, t = 1\text{ Sec.}$	360			Watts
SOA2	Safe Operating Area	$I_{DS} = I_D [\text{Cont.}], V_{DS} = P_D / I_D [\text{Cont.}], t = 1\text{ Sec.}$	360			
$I_{LM}$	Inductive Current Clamped	APT5020BNR	112			Amps
		APT5022BNR	108			

① Repetitive Rating: Pulse width limited by maximum junction temperature.

③ See MIL-STD-750 Method 3471

② Pulse Test: Pulse width < 380  $\mu s$ , Duty Cycle < 2%

④ Starting  $T_j = +25^\circ\text{C}$ ,  $L = 3.3\text{ mH}$ ,  $R_G = 25\Omega$ , Peak  $I_L = 28\text{ A}$

APT Reserves the right to change, without notice, the specifications and information contained herein.

**TO-247AD Package Outline**

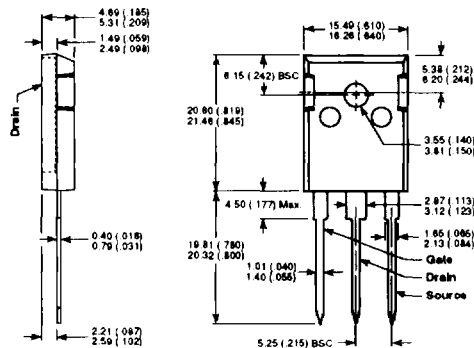

Dimensions in Millimeters and (Inches)