

Rochester Electronics Manufactured Components

Rochester branded components are manufactured using either die/wafers purchased from the original suppliers or Rochester wafers recreated from the original IP. All recreations are done with the approval of the OCM.

Parts are tested using original factory test programs or Rochester developed test solutions to guarantee product meets or exceed the OCM data sheet.

Quality Overview

- ISO-9001
- AS9120 certification
- Qualified Manufacturers List (QML) MIL-PRF-35835
 - Class Q Military
 - Class V Space Level
- Qualified Suppliers List of Distributors (QSLD)
 - Rochester is a critical supplier to DLA and meets all industry and DLA standards.

Rochester Electronics, LLC is committed to supplying products that satisfy customer expectations for quality and are equal to those originally supplied by industry manufacturers.

The original manufacturer's datasheet accompanying this document reflects the performance and specifications of the Rochester manufactured version of this device. Rochester Electronics guarantees the performance of its semiconductor products to the original OEM specifications. 'Typical' values are for reference purposes only. Certain minimum or maximum ratings may be based on product characterization, design, simulation, or sample testing.

FEATURES/BENEFITS

- Pin and function compatible to the 74F240/4, 74FCT240/4 and 74ABT240/4
- Industrial temperature -40°C to 85°C
- CMOS power levels: $<7.5\text{mW}$ static
- Available in DIP, SOIC, QSOP, ZIP, HQSOP
- Undershoot clamp diodes on all inputs
- TTL-compatible input and output levels
- Ground bounce controlled outputs
- Reduced output swing of 0-3.5V
- Military product compliant to MIL-STD-883, Class B

FCT-T 240T, 244T

- JEDEC-FCT spec compatible
- Std. thru D speed grades with 3.8ns t_{PD} for D
- $I_{OL} = 64\text{mA}$ Ind., 48mA Mil.

FCT-T 2240T, 2244T

- Built-in 25Ω series resistor outputs reduce reflection and other system noise
- Std. thru C speed grades with 4.1ns t_{PD} for C
- $I_{OL} = 12\text{mA}$ Ind.

DESCRIPTION

The FCT240T and FCT244T are 8-bit buffers/line drivers with three-state outputs that are ideal for driving high-capacitance loads as in memory address and data buses. The FCT2240T and FCT2244T are 25Ω resistor output versions useful for driving transmission lines and reducing system noise. The 2240 and 2244 series parts can replace the 240/244 series to reduce noise in an existing design. All inputs have clamp diodes for undershoot noise suppression. All outputs have ground bounce suppression (see QSI Application Note AN-001), and outputs will not load an active bus when V_{CC} is removed from the device.

Figure 1. Functional Block Diagram

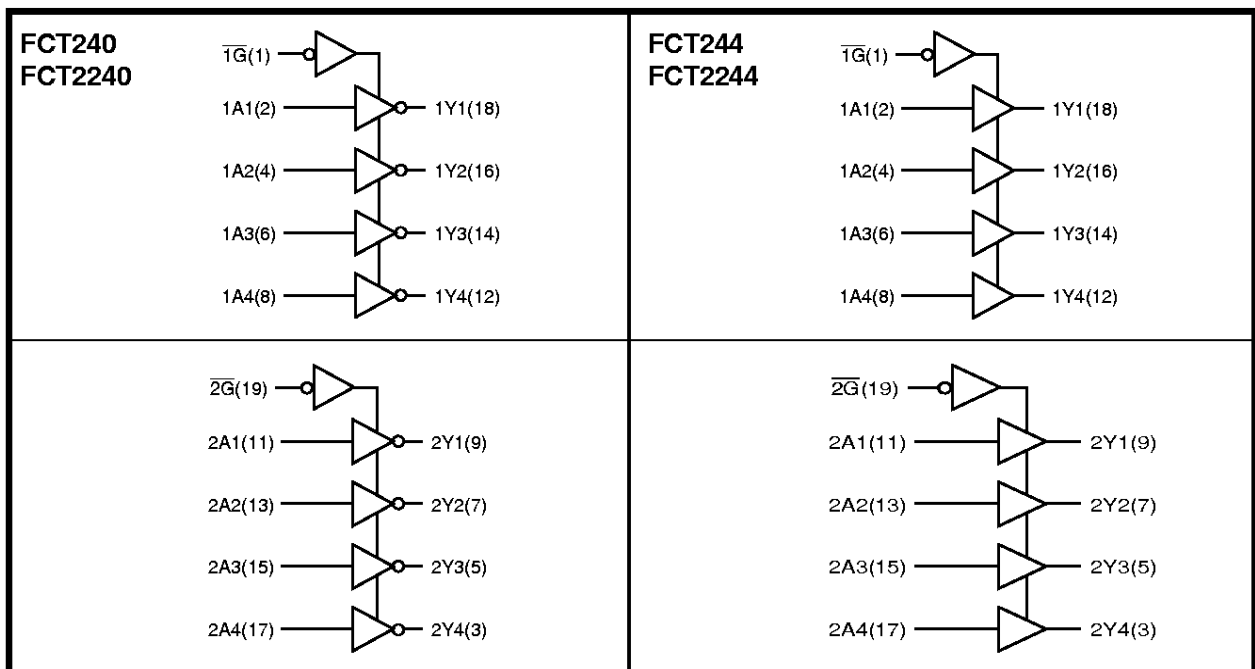

Note: Pin 19 is $\overline{2G}$ on the FCT244.

Figure 2. Pin Configurations (All Pins Top View)

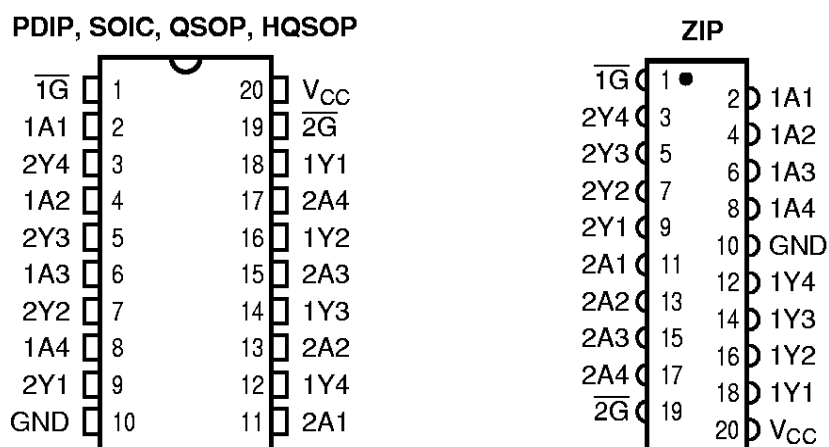

Table 1. Pin Description

Name	I/O	Description
xA4-xA0	I	Data Inputs
xY4-xY0	O	Data Outputs - Three State
$\overline{1G}/\overline{2G}$	I	Output Enables

Table 2. Function Tables

FCT240/FCT2240

$\overline{1G}/\overline{2G}$	Input A	Output Y
H	X	Z
L	L	H
L	H	L

FCT244/FCT2244

$\overline{1G}/\overline{2G}$	Input A	Output Y
H	X	Z
L	L	L
L	H	H

Table 3. Absolute Maximum Ratings

Supply Voltage to Ground	-0.5V to 7.0V
DC Output Voltage V_{OUT}	-0.5V to 7.0V
DC Input Voltage V_{IN}	-0.5V to 7.0V
AC Input Voltage (for a pulse width ≤ 20 ns)	-3.0V
DC Input Diode Current with $V_{IN} < 0$	-20mA
DC Output Diode Current with $V_{OUT} < 0$	-50mA
DC Output Current Max. Sink Current/Pin	120mA
Maximum Power Dissipation	0.5 watts
T_{STG} Storage Temperature	-65° to 150°C

Note: Stresses greater than those listed under ABSOLUTE MAXIMUM RATINGS may cause permanent damage to QSI devices that result in functional or reliability type failures.

Table 4. Capacitance⁽¹⁾

$T_A = 25^\circ\text{C}$, $f = 1\text{MHz}$, $V_{IN} = 0\text{V}$, $V_{OUT} = 0\text{V}$

Pins ⁽²⁾	SOIC	QSOP	PDIP	ZIP	Unit
1, 19	4	4	5	7	pF
2-9,11-18	8	8	9	10	pF

Notes:

1. Capacitance is characterized but not tested.
2. Pin reference for 20-pin package.

Table 5. Power Supply Characteristics

Symbol	Parameter	Test Conditions ⁽¹⁾	Min	Max	Unit
I_{CC}	Quiescent Power Supply Current	$V_{CC} = \text{Max.}$, freq = 0 $0\text{V} \leq V_{IN} \leq 0.2\text{V}$ or $V_{CC}-0.2\text{V} \leq V_{IN} \leq V_{CC}$	—	1.5	mA
ΔI_{CC}	Supply Current per Input @ TTL HIGH	$V_{CC} = \text{Max.}$, $V_{IN} = 3.4\text{V}$, freq = 0 ⁽²⁾	—	2.0	mA
Q_{CCD}	Supply Current per Input per MHz	$V_{CC} = \text{Max.}$, Outputs Open and Enabled One BitToggling @ 50% Duty Cycle Other Inputs at GND or V_{CC} ^(3,4)	—	0.25	mA/ MHz

Notes:

1. For conditions shown as Min. or Max., use the appropriate values specified under DC specifications.
2. Per TTL driven input ($V_{IN} = 3.4\text{V}$).
3. For flip-flops, Q_{CCD} is measured by switching one of the data input pins so that the output changes every clock cycle. This is a measurement of device power consumption only and does not include power to drive load capacitance or tester capacitance. This parameter is guaranteed by design but not tested.
4. I_C can be computed using the above parameters as explained in the Technical Overview section.

Table 6. DC Electrical Characteristics Over Operating Range

Industrial $T_A = -40^{\circ}\text{C}$ to 85°C , $V_{CC} = 5.0\text{V} \pm 5\%$

Military $T_A = -55^{\circ}\text{C}$ to 125°C , $V_{CC} = 5.0\text{V} \pm 10\%$

Symbol	Parameter	Test Conditions	Min	Typ ⁽¹⁾	Max	Unit
V_{IH}	Input HIGH Voltage	Logic HIGH for All Inputs	2.0	—	—	V
V_{IL}	Input LOW Voltage	Logic LOW for All Inputs	—	—	0.8	V
ΔV_T	Input Hysteresis	$V_{TLH} - V_{THL}$ for All Inputs	—	0.2	—	V
$ I_{IH} $ $ I_{IL} $	Input Current Input HIGH or LOW	$V_{CC} = \text{Max.}, 0 \leq V_{IN} < V_{CC}$	—	—	5	μA
$ I_{OZ} $	Off-State Output Current (Hi-Z)	$V_{CC} = \text{Max.}, 0 \leq V_{IN} \leq V_{CC}$	—	—	5	μA
I_{OS}	Short Circuit Current (FCTXXX)	$V_{CC} = \text{Max.}, V_{OUT} = \text{GND}^{(2,3)}$	-60	—	—	mA
I_{OR}	Current Drive (FCT2XXX - 25 Ω)	$V_{CC} = \text{Min.}, V_{OUT} = 2.0\text{V}^{(3)}$	50	—	—	mA
V_{IC}	Input Clamp Voltage	$V_{CC} = \text{Min.}, I_{IN} = -18\text{mA}, T_A = 25^{\circ}\text{C}^{(3)}$	—	-0.7	-1.2	V
V_{OH}	Output HIGH Voltage	$V_{CC} = \text{Min.}$ $I_{OH} = -12\text{mA}$ (MIL) $I_{OH} = -15\text{mA}$ (IND)	2.4 2.4	— —	— —	V
V_{OL}	Output LOW Voltage (FCTXXX)	$V_{CC} = \text{Min.}$ $I_{OL} = 48\text{mA}$ (MIL) $I_{OL} = 64\text{mA}$ (IND)	— —	— —	0.55 0.55	V
V_{OL}	Output LOW Voltage (FCT2XXX - 25 Ω)	$V_{CC} = \text{Min.}$ $I_{OL} = 12\text{mA}$ (MIL) $I_{OL} = 12\text{mA}$ (IND)	— —	— —	0.50 0.50	V
R_{OUT}	Output Resistance (FCT2XXX - 25 Ω)	$V_{CC} = \text{Min.}$ $I_{OL} = 12\text{mA}$ (MIL) $I_{OL} = 12\text{mA}$ (IND)	— 20	25 28	— 40	Ω

Notes:

1. Typical values indicate $V_{CC} = 5.0\text{V}$ and $T_A = 25^{\circ}\text{C}$.
2. Not more than one output should be shorted and the duration is ≤ 1 second.
3. These parameters are guaranteed by design but not tested.

QS54/74FCT240T, 244T, 2240T, 2244T

Table 7. FCT240T, FCT2240T Switching Characteristics Over Operating Range

Industrial $T_A = -40^\circ\text{C}$ to 85°C , $V_{CC} = 5.0\text{V} \pm 5\%$ Military $T_A = -55^\circ\text{C}$ to 125°C , $V_{CC} = 5.0\text{V} \pm 10\%$
 $C_{LOAD} = 50\text{pF}$, $R_{LOAD} = 500\Omega$ unless otherwise noted.

Symbol	Description ⁽¹⁾		2240		240A 2240A		240C 2240C		240D		Unit
			Min	Max	Min	Max	Min	Max	Min	Max	
t_{PHL} t_{PLH}	Propagation Delay Ai to Yi (FCT240)	IND MIL	1.5 1.5	8 9	1.5 1.5	4.8 5.1	1.5 1.5	4.1 4.7	1.5 —	3.8 —	ns
t_{PHL} t_{PLH}	Propagation Delay Ai to Yi (FCT2240)	IND MIL	1.5 1.5	8 9	1.5 1.5	4.8 5.1	1.5 1.5	4.1 4.7	— —	— —	ns
t_{PZH} t_{PZL}	Output Enable Time \bar{G} to Yi (FCT240)	IND MIL	1.5 1.5	10 10.5	1.5 1.5	6.2 6.5	1.5 1.5	5.8 6.5	1.5 —	5.6 —	ns
t_{PZH} t_{PZL}	Output Enable Time \bar{G} to Yi (FCT2240)	IND MIL	1.5 1.5	10 10.5	1.5 1.5	6.2 6.5	1.5 1.5	5.8 6.5	— —	— —	ns
t_{PHZ} t_{PLZ}	Output Disable Time \bar{G} to Yi	IND ⁽²⁾ MIL ⁽²⁾	1.5 1.5	9.5 10	1.5 1.5	5.6 5.9	1.5 1.5	5.2 5.7	1.5 —	5.2 —	ns

Table 8. FCT244T, FCT2244T Switching Characteristics Over Operating Range

Industrial $T_A = -40^\circ\text{C}$ to 85°C , $V_{CC} = 5.0\text{V} \pm 5\%$ Military $T_A = -55^\circ\text{C}$ to 125°C , $V_{CC} = 5.0\text{V} \pm 10\%$
 $C_{LOAD} = 50\text{pF}$, $R_{LOAD} = 500\Omega$ unless otherwise noted.

Symbol	Description ⁽¹⁾		244 2244		244A 2244A		244C 2244C		244D		Unit
			Min	Max	Min	Max	Min	Max	Min	Max	
t_{PHL} t_{PLH}	Propagation Delay Ai to Yi (FCT244)	IND MIL	1.5 1.5	6.5 7.5	1.5 1.5	4.8 5.1	1.5 1.5	4.1 4.6	1.5 —	3.8 —	ns
t_{PHL} t_{PLH}	Propagation Delay Ai to Yi (FCT2244)	IND MIL	1.5 1.5	6.5 7.5	1.5 1.5	4.8 5.1	1.5 1.5	4.1 4.6	1.5 —	3.8 —	ns
t_{PZH} t_{PZL}	Output Enable Time \bar{G} to Yi (FCT244)	IND MIL	1.5 1.5	8 8.5	1.5 1.5	6.2 6.5	1.5 1.5	5.8 6.5	1.5 —	5.6 —	ns
t_{PZH} t_{PZL}	Output Enable Time \bar{G} to Yi (FCT2244)	IND MIL	1.5 1.5	8 8.5	1.5 1.5	6.2 6.5	1.5 1.5	5.8 6.5	1.5 —	5.6 —	ns
t_{PHZ} t_{PLZ}	Output Disable Time \bar{G} to Yi	IND ⁽²⁾ MIL ⁽²⁾	1.5 1.5	7 7.5	1.5 1.5	5.6 5.9	1.5 1.5	5.2 5.7	1.5 —	5.2 —	ns

Notes:

1. Minimums guaranteed but not tested.
2. This parameter is guaranteed by design but not tested.
3. See Test Circuit and Waveforms.