



CYPRESS

CY54/74FCT2652T

## 8-Bit Registered Transceiver

### Features

- Function and pinout compatible with FCT and F logic
- FCT-C speed at 5.4 ns max. (Com'l)  
FCT-A speed at 6.3 ns max. (Com'l)
- 25Ω output series resistors to reduce transmission line reflection noise
- Reduced  $V_{OH}$  (typically = 3.3V) versions of equivalent FCT functions
- Edge-rate control circuitry for significantly improved noise characteristics
- Power-off disable feature
- Matched rise and fall times
- Fully compatible with TTL input and output logic levels
- Sink current           12 mA (Com'l),  
                              12 mA (Mil)
- Source current        15 mA (Com'l),  
                              12 mA (Mil)
- ESD > 2000V

- Independent register for A and B buses
- Multiplexed real-time and stored data transfer

### Functional Description

The FCT2652T consists of bus transceiver circuits, D-type flip-flops, and control circuitry arranged for multiplexed transmission of data directly from the input bus or from the internal storage registers. GAB and GBA control pins are provided to control the transceiver functions. SAB and SBA control pins are provided to select either real-time or stored data transfer.

On-chip termination resistors are added to the outputs to reduce system noise caused by reflections. The FCT2652T can replace the FCT652T to reduce noise in an existing design.

The circuitry used for select control will eliminate the typical decoding glitch that

occurs in a multiplexer during transition between stored and real-time data. A LOW input level selects real-time data and a HIGH selects stored data.

Data on the A or B data bus, or both, can be stored in the internal D flip-flops by LOW-to-HIGH transitions at the appropriate clock pins (CPAB or CPBA), regardless of the select or enable control pins. When SAB and SBA are in the real-time transfer mode, it is also possible to store data without using the internal D-type flip-flops by simultaneously enabling GAB and GBA. In this configuration, each output reinforces its input. Thus, when all other data sources to the two sets of bus lines are at high impedance, each set of bus lines will remain at its last state.

The outputs are designed with a power-off disable feature to allow for live insertion of boards.

### Logic Block Diagram

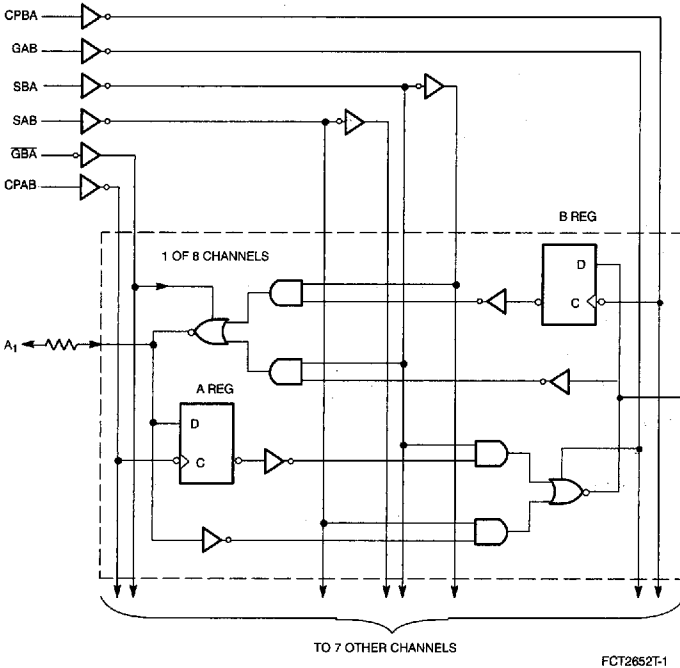

### Pin Configurations

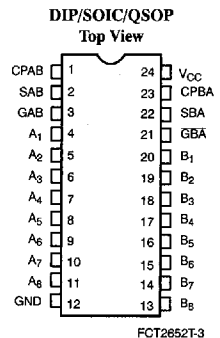
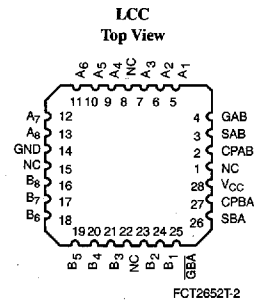

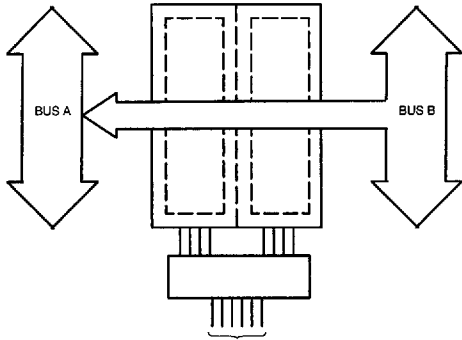

GAB	GBA	CPAB	CPBA	SAB	SBA
L	L	X	X	X	L

**Real-Time Transfer  
Bus B to Bus A**

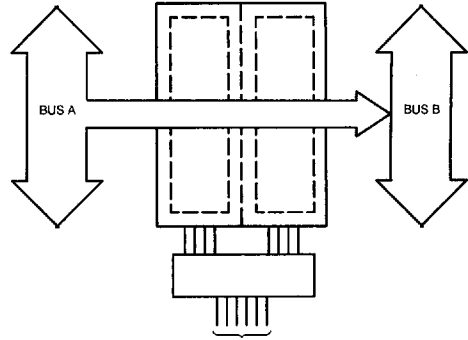

GAB	GBA	CPAB	CPBA	SAB	SBA
H	H	X	X	L	X

**Real-Time Transfer  
Bus A to Bus B**

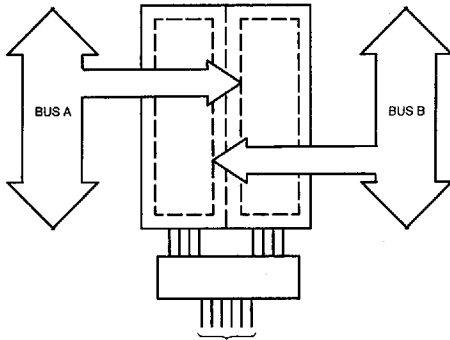

GAB	GBA	CPAB	CPBA	SAB	SBA
X	H	X	X	X	X
X	X	X	X	X	X
L	H	X	X	X	X

**Store Data from A and/or B**

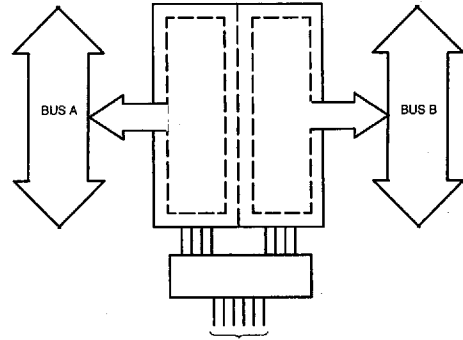

GAB	GBA	CPAB	CPBA	SAB	SBA
H	L	H or L	H or L	H	H

**Transferred Stored Data  
to A and/or B**

**Function Table<sup>[1]</sup>**

Inputs						Data I/O		Operation or Function
GAB	GBA	CPAB	CPBA	SAB	SBA	A <sub>1</sub> thru A <sub>8</sub>	B <sub>1</sub> thru B <sub>8</sub>	
L L	H H	H or L ┐	H or L ┐	X X	X X	Input	Input	Isolation Store A and B Data
X H	H H	┐ ┐	H or L ┐	X X <sup>[1]</sup>	X X	Input Input	Unspecified <sup>[2]</sup> Output	Store A, Hold B Store A in both registers
L L	X L	H or L ┐	┐ ┐	X X	X X <sup>[1]</sup>	Unspecified <sup>[2]</sup> Output	Input Input	Hold A, Store B Store B in both registers
L L	L L	X X	X H or L	X X	L H	Output	Input	Real-Time B Data to A Bus Stored B Data to A Bus
H H	H H	X H or L	X X	L H	X X	Input	Output	Real-Time A Data to B Bus Stored A Data to B Bus
H	L	H or L	H or L	H	H	Output	Output	Stored A Data to B Bus and Stored B Data to A Bus

**Maximum Ratings<sup>[3, 4]</sup>**

(Above which the useful life may be impaired. For user guidelines, not tested.)

Storage Temperature	-65°C to +150°C
Ambient Temperature with Power Applied	-65°C to +135°C
Supply Voltage to Ground Potential	-0.5V to +7.0V
DC Input Voltage	-0.5V to +7.0V
DC Output Voltage	-0.5V to +7.0V
DC Output Current (Maximum Sink Current/Pin)	120 mA
Power Dissipation	0.5W

Static Discharge Voltage ..... >2001V  
(per MIL-STD-883, Method 3015)

**Operating Range**

Range	Range	Ambient Temperature	V <sub>CC</sub>
Commercial	CT, DT	0°C to +70°C	5V ± 5%
Commercial	T, AT	-40°C to +85°C	5V ± 5%
Military <sup>[5]</sup>	All	-55°C to +125°C	5V ± 10%

**Notes:**

- Select control=L: clocks can occur simultaneously.  
Select control=H: clocks must be staggered in order to load both registers. H = HIGH Voltage Level. L = LOW Voltage Level.  
X = Don't Care.
- The data output functions may be enabled or disabled by various signals at the GAB or GBA inputs. Data input functions are always enabled, i.e., data at the bus pins will be stored on every LOW-to-HIGH transition on the clock inputs.
- Unless otherwise noted, these limits are over the operating free-air temperature range.
- Unused inputs must always be connected to an appropriate logic voltage level, preferably either V<sub>CC</sub> or ground.
- T<sub>A</sub> is the "instant on" case temperature.

**Electrical Characteristics Over the Operating Range**

Parameter	Description	Test Conditions		Min.	Typ. <sup>[6]</sup>	Max.	Unit
V <sub>OH</sub>	Output HIGH Voltage	V <sub>CC</sub> =Min., I <sub>OH</sub> =-15 mA	Com'l	2.4	3.3		V
		V <sub>CC</sub> =Min., I <sub>OH</sub> =-12 mA	Mil	2.4	3.3		V
V <sub>OL</sub>	Output LOW Voltage	V <sub>CC</sub> =Min., I <sub>OL</sub> =12 mA	Com'l		0.3	0.55	V
		V <sub>CC</sub> =Min., I <sub>OL</sub> =12 mA	Mil		0.3	0.55	V
R <sub>OUT</sub>	Output Resistance	V <sub>CC</sub> =Min., I <sub>OL</sub> =12 mA	Com'l	20	25	40	Ω
		V <sub>CC</sub> =Min., I <sub>OL</sub> =12 mA	Mil		25		Ω
V <sub>IH</sub>	Input HIGH Voltage			2.0			V
V <sub>IL</sub>	Input LOW Voltage					0.8	V
V <sub>H</sub>	Hysteresis <sup>[7]</sup>	All inputs			0.2		V
V <sub>IK</sub>	Input Clamp Diode Voltage	V <sub>CC</sub> =Min., I <sub>IN</sub> =-18 mA			-0.7	-1.2	V
I <sub>IH</sub>	Input HIGH Current	V <sub>CC</sub> =Max., V <sub>IN</sub> =V <sub>CC</sub>				5	μA
I <sub>IH</sub>	Input HIGH Current	V <sub>CC</sub> =Max., V <sub>IN</sub> =2.7V				±1	μA
I <sub>IL</sub>	Input LOW Current	V <sub>CC</sub> =Max., V <sub>IN</sub> =0.5V				±1	μA
I <sub>OZH</sub>	Off State HIGH-Level Output Current	V <sub>CC</sub> =Max., V <sub>OUT</sub> =2.7V				10	μA
I <sub>OZL</sub>	Off State LOW-Level Output Current	V <sub>CC</sub> =Max., V <sub>OUT</sub> =0.5V				-10	μA
I <sub>OS</sub>	Output Short Circuit Current <sup>[8]</sup>	V <sub>CC</sub> =Max., V <sub>OUT</sub> =0.0V		-60	-120	-225	mA
I <sub>OFF</sub>	Power-Off Disable	V <sub>CC</sub> =0V, V <sub>OUT</sub> =4.5V				±1	μA

**Capacitance<sup>[7]</sup>**

Parameter	Description	Test Conditions	Typ. <sup>[6]</sup>	Max.	Unit
C <sub>IN</sub>	Input Capacitance		5	10	pF
C <sub>OUT</sub>	Output Capacitance		9	12	pF

**Notes:**

6. Typical values are at V<sub>CC</sub>=5.0V, T<sub>A</sub>=+25°C ambient.
7. This parameter is guaranteed but not tested.
8. Not more than one output should be shorted at a time. Duration of short should not exceed one second. The use of high-speed test apparatus and/or sample and hold techniques are preferable in order

to minimize internal chip heating and more accurately reflect operational values. Otherwise prolonged shorting of a high output may raise the chip temperature well above normal and thereby cause invalid readings in other parametric tests. In any sequence of parameter tests, I<sub>OS</sub> tests should be performed last.

**Power Supply Characteristics**

Parameter	Description	Test Conditions	Typ. <sup>[6]</sup>	Max.	Unit
I <sub>CC</sub>	Quiescent Power Supply Current	V <sub>CC</sub> =Max., V <sub>IN</sub> ≤ 0.2V, V <sub>IN</sub> ≥ V <sub>CC</sub> -0.2V	0.1	0.2	mA
ΔI <sub>CC</sub>	Quiescent Power Supply Current (TTL inputs HIGH)	V <sub>CC</sub> =Max., V <sub>IN</sub> =3.4V, <sup>[9]</sup> f <sub>1</sub> =0, Outputs Open	0.5	2.0	mA
I <sub>CCD</sub>	Dynamic Power Supply Current <sup>[10]</sup>	V <sub>CC</sub> =Max., One Input Toggling, 50% Duty Cycle, Outputs Open, GAB=GND, GBA=GND, V <sub>IN</sub> ≤ 0.2V or V <sub>IN</sub> ≥ V <sub>CC</sub> -0.2V	0.06	0.12	mA/ MHz
I <sub>C</sub>	Total Power Supply Current <sup>[11]</sup>	V <sub>CC</sub> =Max., f <sub>0</sub> =10 MHz, 50% Duty Cycle, Outputs Open, One Bit Toggling at f <sub>1</sub> =5 MHz, GAB=GND, GBA=GND, SAB=CPAB=GND SBA=V <sub>CC</sub> , V <sub>IN</sub> ≤ 0.2V or V <sub>IN</sub> ≥ V <sub>CC</sub> -0.2V	0.7	1.4	mA
		V <sub>CC</sub> =Max., f <sub>0</sub> =10 MHz, 50% Duty Cycle, Outputs Open, One Bit Toggling at f <sub>1</sub> =5 MHz, GAB=GND, GBA=GND, SAB=CPAB=GND SBA=V <sub>CC</sub> , V <sub>IN</sub> =3.4V or V <sub>IN</sub> =GND	1.2	3.4	mA
		V <sub>CC</sub> =Max., f <sub>0</sub> =10 MHz, 50% Duty Cycle, Outputs Open, Eight Bits Toggling at f <sub>1</sub> =5 MHz, GAB=GBA=GND, SAB=CPAB=GND SBA=V <sub>CC</sub> , V <sub>IN</sub> ≤ 0.2V or V <sub>IN</sub> ≥ V <sub>CC</sub> -0.2V	2.8	5.6 <sup>[12]</sup>	mA
		V <sub>CC</sub> =Max., f <sub>0</sub> =10 MHz, 50% Duty Cycle, Outputs Open, Eight Bits Toggling at f <sub>1</sub> =5 MHz, GAB=GBA=GND, SAB=CPAB=GND SBA=V <sub>CC</sub> , V <sub>IN</sub> =3.4V or V <sub>IN</sub> =GND	5.1	14.6 <sup>[12]</sup>	mA

**Notes:**

9. Per TTL driven input (V<sub>IN</sub>=3.4V); all other inputs at V<sub>CC</sub> or GND.  
 10. This parameter is not directly testable, but is derived for use in Total Power Supply calculations.

11. I<sub>C</sub> = I<sub>QUIESCENT</sub> + I<sub>INPUTS</sub> + I<sub>DYNAMIC</sub>  
 I<sub>C</sub> = I<sub>CC</sub> + ΔI<sub>CCD<sub>H</sub></sub>N<sub>T</sub> + I<sub>CCD</sub>(f<sub>0</sub>/2 + f<sub>1</sub>N<sub>1</sub>)  
 I<sub>CC</sub> = Quiescent Current with CMOS input levels  
 ΔI<sub>CC</sub> = Power Supply Current for a TTL HIGH input (V<sub>IN</sub>=3.4V)  
 D<sub>H</sub> = Duty Cycle for TTL inputs HIGH

N<sub>T</sub> = Number of TTL inputs at D<sub>H</sub>

I<sub>CCD</sub> = Dynamic Current caused by an input transition pair (HLH or LHL)

f<sub>0</sub> = Clock frequency for registered devices, otherwise zero

f<sub>1</sub> = Input signal frequency

N<sub>1</sub> = Number of inputs changing at f<sub>1</sub>

All currents are in milliamps and all frequencies are in megahertz.

12. Values for these conditions are examples of the I<sub>CC</sub> formula. These limits are guaranteed but not tested.

**Switching Characteristics<sup>[13]</sup> Over the Operating Range**

Parameter	Description	FCT2652T				FCT2652AT				Unit	Fig. No. <sup>[14]</sup>
		Military		Commercial		Military		Commercial			
		Min. <sup>[15]</sup>	Max.	Min. <sup>[15]</sup>	Max.	Min. <sup>[15]</sup>	Max.	Min. <sup>[15]</sup>	Max.		
t <sub>PLH</sub> t <sub>PHL</sub>	Propagation Delay Bus to Bus	1.5	11.0	1.5	9.0	1.5	7.7	1.5	6.3	ns	1, 3
t <sub>PZH</sub> t <sub>PZL</sub>	Output Enable Time Enable to Bus	1.5	15.0	1.5	14.0	1.5	10.5	1.5	9.8	ns	1, 7, 8
t <sub>PHZ</sub> t <sub>PLZ</sub>	Output Disable Time Enable to Bus	1.5	11.0	1.5	9.0	1.5	7.7	1.5	6.3	ns	1, 7, 8
t <sub>PLH</sub> t <sub>PHL</sub>	Propagation Delay Clock to Bus	1.5	10.0	1.5	9.0	1.5	7.0	1.5	6.3	ns	1, 5
t <sub>PLH</sub> t <sub>PHL</sub>	Propagation Delay SBA or SAB to A or B	1.5	12.0	1.5	11.0	1.5	8.4	1.5	7.7	ns	1, 5
t <sub>S</sub>	Set-Up Time HIGH or LOW Bus to Clock	4.5		4.0		2.0		2.0		ns	4
t <sub>H</sub>	Hold Time HIGH or LOW Bus to Clock	2.0		2.0		1.5		1.5		ns	4
t <sub>w</sub>	Clock Pulse Width, <sup>[16]</sup> HIGH or LOW	6.0		6.0		5.0		5.0		ns	5

Parameter	Description	FCT2652CT				FCT2652DT		Unit	Fig. No. <sup>[14]</sup>
		Military		Commercial		Commercial			
		Min. <sup>[15]</sup>	Max.	Min. <sup>[15]</sup>	Max.	Min. <sup>[15]</sup>	Max.		
t <sub>PLH</sub> t <sub>PHL</sub>	Propagation Delay Bus to Bus	1.5	6.0	1.5	5.4	1.5	4.4	ns	1, 3
t <sub>PZH</sub> t <sub>PZL</sub>	Output Enable Time Enable to Bus	1.5	8.9	1.5	7.8	1.5	5.0	ns	1, 3
t <sub>PHZ</sub> t <sub>PLZ</sub>	Output Disable Time Enable to Bus	1.5	7.7	1.5	6.3	1.5	4.3	ns	1, 7, 8
t <sub>PLH</sub> t <sub>PHL</sub>	Propagation Delay Clock to Bus	1.5	6.3	1.5	5.7	1.5	4.4	ns	1, 5
t <sub>PLH</sub> t <sub>PHL</sub>	Propagation Delay SBA or SAB to A or B	1.5	7.0	1.5	6.2	1.5	5.0	ns	1, 5
t <sub>S</sub>	Set-Up Time HIGH or LOW Bus to Clock	2.0		2.0		1.5		ns	4
t <sub>H</sub>	Hold Time HIGH or LOW Bus to Clock	1.5		1.5		1.0		ns	4
t <sub>w</sub>	Pulse Width, <sup>[16]</sup> HIGH or LOW	5.0		5.0		3.0		ns	5

Shaded areas contain preliminary information.

**Notes:**

13. AC Characteristics guaranteed with C<sub>L</sub> = 50 pF as shown in Figure 1 in "Parameter Measurement Information" in the General Information Section.
14. See "Parameter Measurement Information" in the General Information Section.
15. Minimum limits are guaranteed but not tested on Propagation Delays.
16. With one data channel toggling, t<sub>w(L)</sub> = t<sub>w(H)</sub> = 4.0 ns and t<sub>r</sub> = t<sub>f</sub> = 1.0 ns.

**Ordering Information**

Speed (ns)	Ordering Code	Package Name	Package Type	Operating Range
4.4	CY74FCT2652DTQC	Q13	24-Lead (150-Mil) QSOP	Commercial
	CY74FCT2652DTSOC	S13	24-Lead (300-Mil) Molded SOIC	
5.4	CY74FCT2652CTPC	P13/13A	24-Lead (300-Mil) Molded DIP	Commercial
	CY74FCT2652CTOC	Q13	24-Lead (150-Mil) QSOP	
	CY74FCT2652CTSOC	S13	24-Lead (300-Mil) Molded SOIC	
6.0	CY54FCT2652CTDMB	D14	24-Lead (300-Mil) CerDIP	Military
	CY54FCT2652CTLMB	L64	28-Square Leadless Chip Carrier	
6.3	CY74FCT2652ATPC	P13/13A	24-Lead (300-Mil) Molded DIP	Commercial
	CY74FCT2652ATQC	Q13	24-Lead (150-Mil) QSOP	
	CY74FCT2652ATSOC	S13	24-Lead (300-Mil) Molded SOIC	
7.7	CY54FCT2652ATDMB	D14	24-Lead (300-Mil) CerDIP	Military
	CY54FCT2652ATLMB	L64	28-Square Leadless Chip Carrier	
9.0	CY74FCT2652TPC	P13/13A	24-Lead (300-Mil) Molded DIP	Commercial
	CY74FCT2652TQC	Q13	24-Lead (150-Mil) QSOP	
	CY74FCT2652TSOC	S13	24-Lead (300-Mil) Molded SOIC	
11.0	CY54FCT2652TDMB	D14	24-Lead (300-Mil) CerDIP	Military
	CY54FCT2652TLMB	L64	28-Square Leadless Chip Carrier	

Shaded areas contain preliminary information.

Document #: 38-00344-A