

### FEATURES

- **FREQUENCY RESPONSE:** 1.5 GHz
- **HIGH GAIN:** 33 dB (UPC2710T)
- **SATURATED OUTPUT POWER:** +13.5 (UPC2710T)
- **INTERNAL CURRENT REGULATION MINIMIZES GAIN CHANGE OVER TEMPERATURE**
- **5 V SINGLE SUPPLY VOLTAGE**
- **SUPER SMALL PACKAGE**
- **TAPE AND REEL PACKAGING OPTION AVAILABLE**

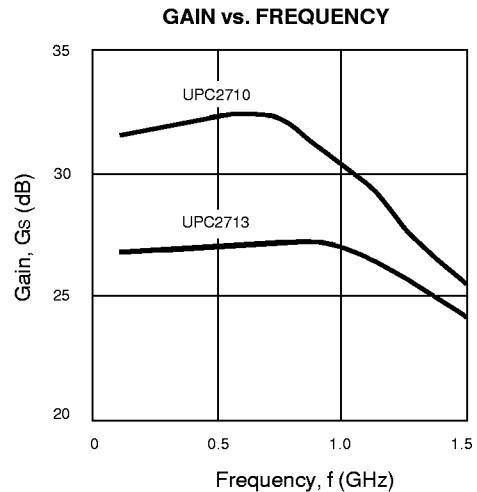

### DESCRIPTION

The UPC2710T and UPC2713T are Silicon Monolithic integrated circuits manufactured using the NESAT III process. These devices are suitable for applications which require high gain and wide-band operation. They are designed for low cost gain stages in cellular radios, GPS receivers, DBS tuners, PCN, and test/measurement equipment.

NEC's stringent quality assurance and test procedures ensure the highest reliability and performance.

### ELECTRICAL CHARACTERISTICS (T<sub>A</sub> = 25 °C, f = 0.5 GHz, V<sub>CC</sub> = 5 V)

PART NUMBER PACKAGE OUTLINE			UPC2710T T06			UPC2713T T06		
SYMBOLS	PARAMETERS AND CONDITIONS	UNITS	MIN	TYP	MAX	MIN	TYP	MAX
I <sub>CC</sub>	Circuit Current (no signal)	mA	16	22	29	9	12	15
G <sub>s</sub>	Small Signal Gain	dB	30	33	36.5	26	29	33
f <sub>U</sub>	Upper Limit Operating Frequency (The gain at f <sub>U</sub> is 3 dB down from the gain at 0.1 GHz)	GHz	0.7	1.0		0.9	1.2	
ΔG <sub>s</sub>	Gain Flatness, f = 0.1 ~ 0.6 GHz f = 0.1 ~ 0.8 GHz	dB		±0.8			±0.8	
P <sub>SAT</sub>	Saturated Output Power	dBm	11	13.5		4	7	
P <sub>1dB</sub>	Output Power at 1dB Compression Point	dBm		7.5			-4	
NF	Noise Figure	dB		3.5	5		3.2	4.5
RL <sub>IN</sub>	Input Return Loss	dB	3	6		10	13	
RL <sub>OUT</sub>	Output Return Loss	dB	9	12		6	9	
ISOL	Isolation	dB	34	39		35	40	
ΔG <sub>T</sub>	Gain -Temperature Coefficient	dB/°C		-0.006			-0.016	
R <sub>TH</sub>	Thermal Resistance (Junction to Ambient)	°C/W			200			200

# UPC2710T, UPC2713T

## ABSOLUTE MAXIMUM RATINGS<sup>1</sup> (T<sub>A</sub> = 25°C)

SYMBOLS	PARAMETERS	UNITS	RATINGS
V <sub>CC</sub>	Supply Voltage	V	6
P <sub>IN</sub>	Input Power	dBm	+10
P <sub>T</sub>	Power Dissipation	mW	280 <sup>2</sup>
T <sub>OP</sub>	Operating Temperature	°C	-40 to +85
T <sub>STG</sub>	Storage Temperature	°C	-55 to +150

**Notes:**

1. Operation in excess of any one of these parameters may result in permanent damage.
2. Mounted on 50 x 50 x 1.6 mm epoxy glass PWB (T<sub>A</sub> = +85°C).

## RECOMMENDED OPERATING CONDITIONS

SYMBOL	PARAMETER	UNITS	MIN	TYP	MAX
V <sub>CC</sub>	Supply Voltage	V	4.5	5.0	5.5

## TEST CIRCUIT

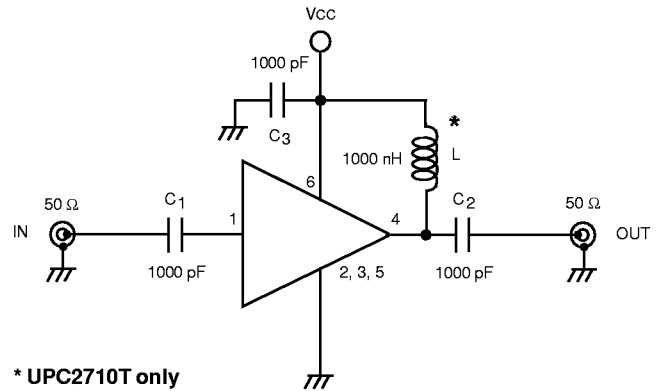

## TYPICAL PERFORMANCE CURVES (T<sub>A</sub> = 25°C)

**CIRCUIT CURRENT vs. VOLTAGE**

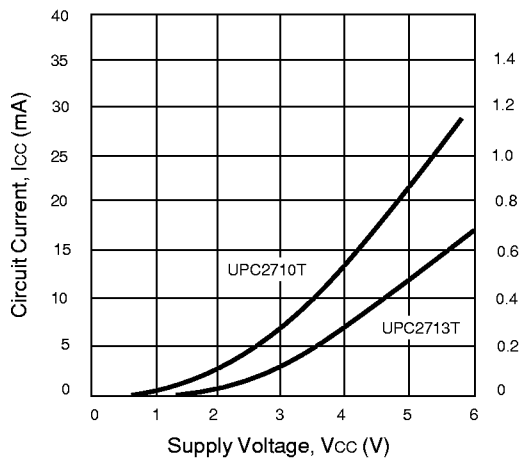

**CIRCUIT CURRENT vs. TEMPERATURE**

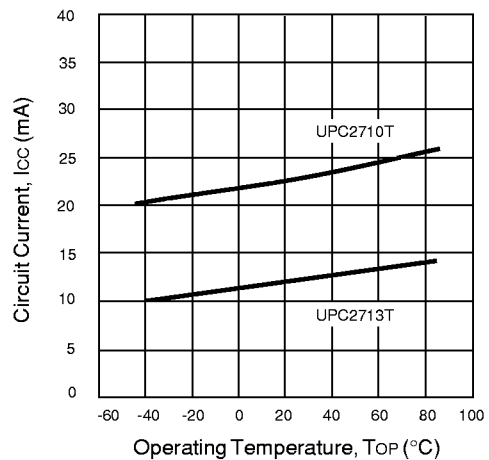

**UPC2710T NOISE FIGURE AND INSERTION GAIN vs. FREQUENCY**

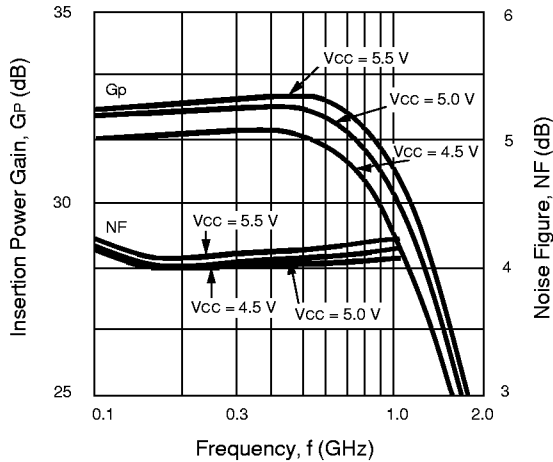

**UPC2713T NOISE FIGURE AND INSERTION GAIN vs. FREQUENCY**

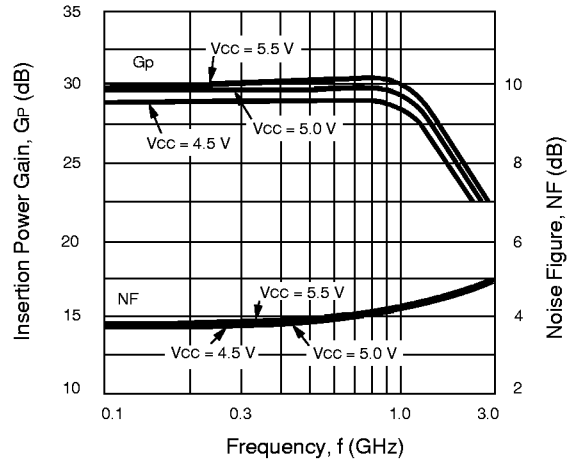

**TYPICAL PERFORMANCE CURVES** ( $T_A = 25^\circ\text{C}$ )

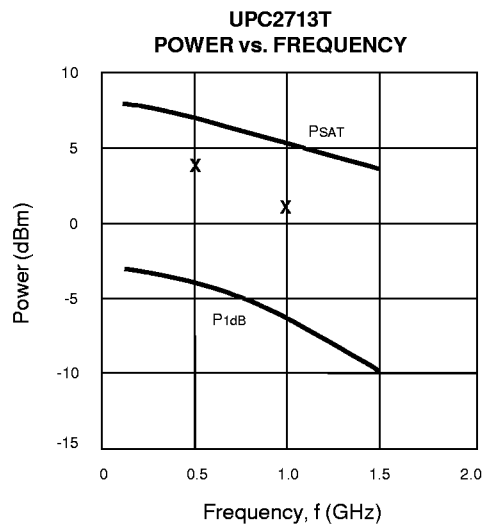
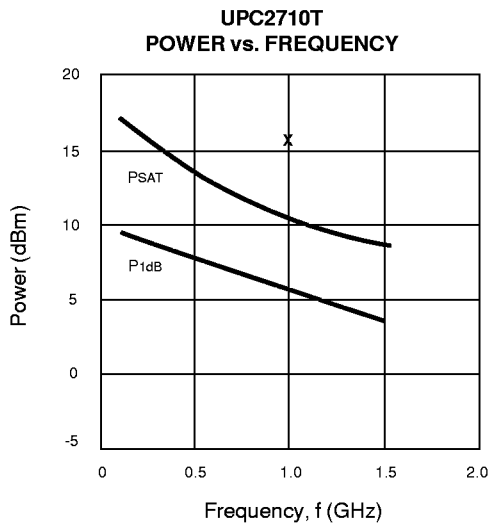
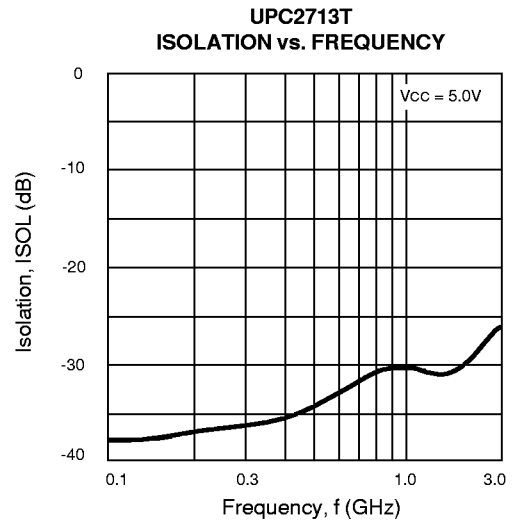
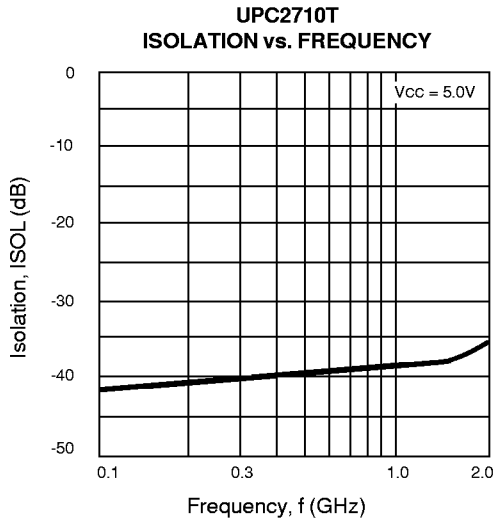
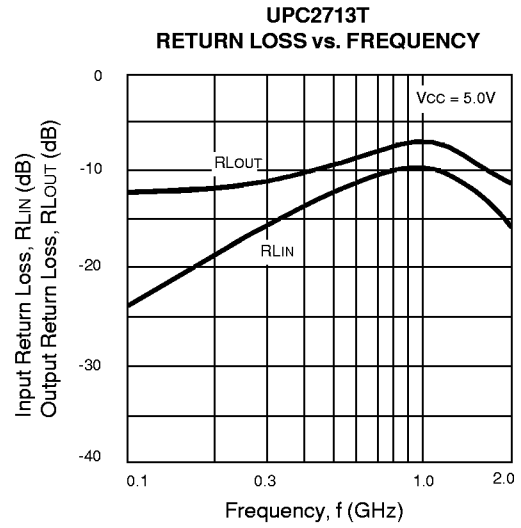
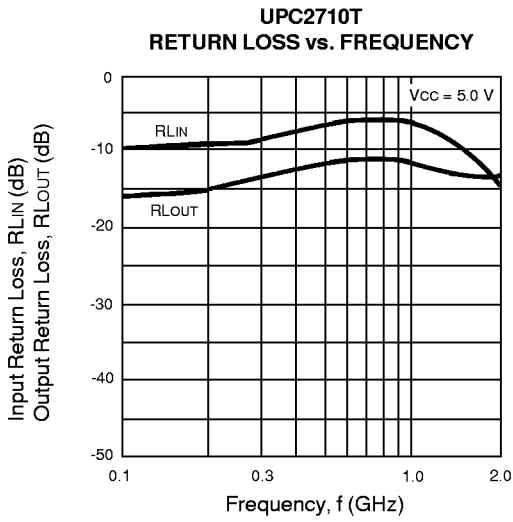

X: Typical SSB Third Order Intercept Point

X: Typical SSB Third Order Intercept Point

TYPICAL PERFORMANCE CURVES (TA = 25° C)

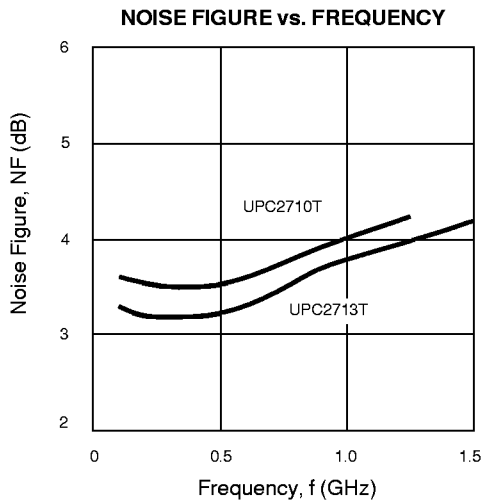
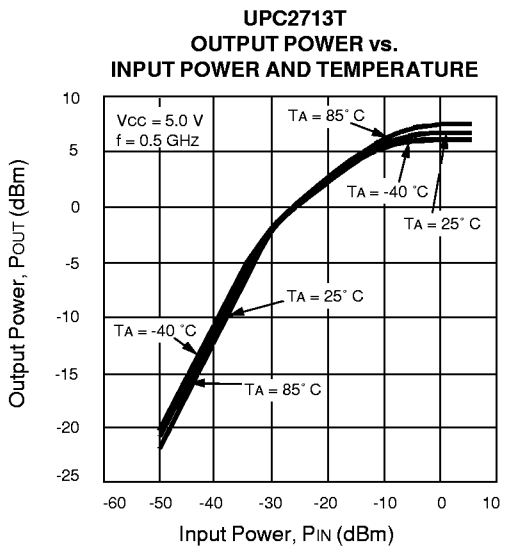
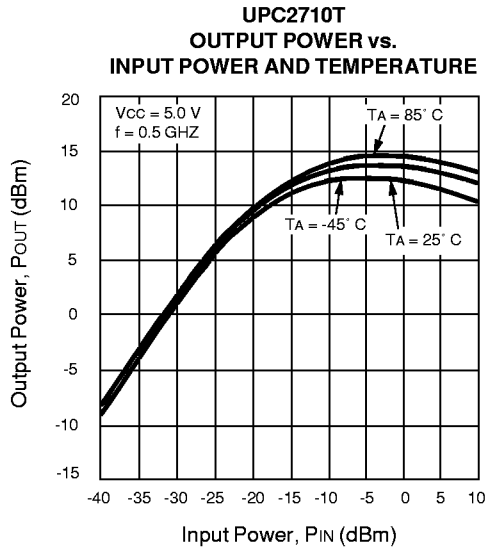
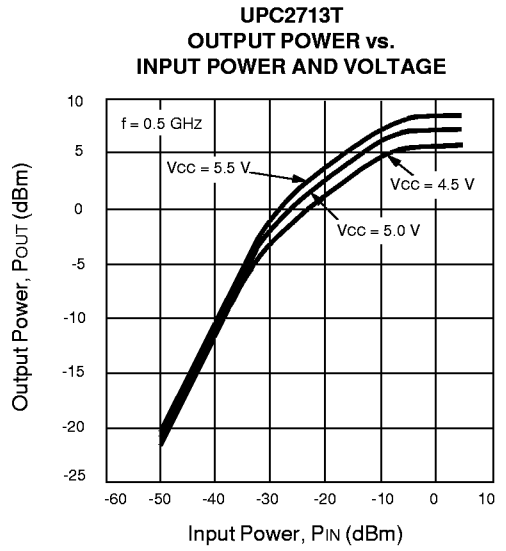
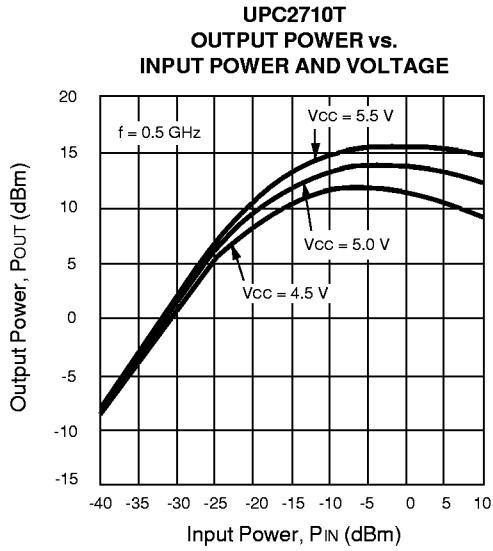

# UPC2710T, UPC2713T

## TYPICAL SCATTERING PARAMETERS (T<sub>A</sub> = 25° C)

### UPC2710T

V<sub>CC</sub> = 5 V, I<sub>CC</sub> = 22 mA

FREQUENCY (GHz)	S <sub>11</sub>		S <sub>21</sub>		S <sub>12</sub>		S <sub>22</sub>		K <sup>1</sup>	S <sub>21</sub> (dB)
	MAG	ANG	MAG	ANG	MAG	ANG	MAG	ANG		
0.10	0.322	-0.3	37.7	-5.9	0.013	17.1	0.200	-11.7	1.06	31.5
0.20	0.346	3.3	38.8	-17.0	0.012	19.8	0.208	-15.4	1.07	31.8
0.30	0.383	2.1	40.2	-28.0	0.009	22.5	0.231	-23.5	1.21	32.1
0.40	0.429	-1.7	41.6	-40.4	0.009	25.1	0.258	-34.2	1.10	32.4
0.50	0.465	-9.4	42.1	-54.1	0.012	27.8	0.273	-47.2	0.86	32.5
0.60	0.486	-17.8	42.3	-68.3	0.013	30.5	0.305	-60.9	0.79	32.5
0.70	0.487	-27.2	41.1	-83.2	0.013	33.1	0.319	-77.8	0.82	32.3
0.80	0.468	-36.5	39.1	-97.9	0.013	35.8	0.320	-96.2	0.89	31.9
0.90	0.423	-44.5	35.4	-111.7	0.013	38.5	0.297	-115.4	1.04	31.0
1.00	0.392	-50.3	32.9	-123.4	0.014	41.2	0.260	-128.2	1.10	30.4
1.10	0.349	-56.6	30.0	-135.5	0.014	43.9	0.240	-142.2	1.22	29.6
1.20	0.301	-61.0	26.8	-146.8	0.015	46.6	0.216	-156.3	1.31	28.6
1.30	0.257	-63.2	23.8	-156.8	0.016	49.2	0.192	-169.7	1.40	27.5
1.40	0.217	-63.5	21.1	-165.9	0.016	51.6	0.173	176.0	1.56	26.5
1.50	0.184	-59.9	18.8	-174.2	0.017	54.5	0.155	162.3	1.65	25.5

### UPC2713T

V<sub>CC</sub> = 5 V, I<sub>CC</sub> = 12 mA

FREQUENCY (GHz)	S <sub>11</sub>		S <sub>21</sub>		S <sub>12</sub>		S <sub>22</sub>		K <sup>1</sup>	S <sub>21</sub> (dB)
	MAG	ANG	MAG	ANG	MAG	ANG	MAG	ANG		
0.10	0.350	-21.8	21.9	-8.1	0.006	25.6	0.286	-10.3	3.07	26.8
0.20	0.290	-33.1	22.0	-25.3	0.006	24.9	0.298	-16.1	3.17	26.9
0.30	0.243	-41.7	22.1	-37.3	0.007	23.7	0.313	-25.6	2.77	26.9
0.40	0.207	-47.3	22.3	-48.6	0.007	22.4	0.327	-35.2	2.78	27.0
0.50	0.185	-50.5	22.4	-60.0	0.007	21.6	0.336	-45.4	2.78	27.0
0.60	0.176	-54.0	22.6	-72.7	0.008	20.1	0.348	-56.9	2.41	27.1
0.70	0.161	-57.5	22.8	-85.7	0.008	19.0	0.359	-69.0	2.39	27.1
0.80	0.148	-60.2	22.9	-100.7	0.009	18.3	0.366	-82.9	2.13	27.2
0.90	0.127	-63.9	22.8	-114.8	0.009	17.2	0.366	-96.8	2.15	27.2
1.00	0.111	-62.9	22.3	-132.0	0.009	16.4	0.359	-111.8	2.23	27.0
1.10	0.097	-56.5	21.6	-147.6	0.010	15.7	0.343	-126.8	2.12	26.7
1.20	0.095	-48.2	20.6	-163.1	0.010	14.4	0.320	-142.3	2.24	26.3
1.30	0.098	-40.1	18.9	-177.8	0.010	13.1	0.291	-156.6	2.47	25.5
1.40	0.110	-35.7	17.6	168.3	0.010	12.0	0.263	-171.7	2.68	24.9
1.50	0.129	-34.6	15.6	154.8	0.011	11.8	0.234	174.3	2.77	23.9
1.60	0.145	-36.2	14.2	142.7	0.012	11.2	0.208	160.8	2.81	23.0
1.70	0.161	-40.0	12.6	130.5	0.013	10.8	0.185	147.1	2.92	22.0
1.80	0.179	-44.7	11.4	120.9	0.014	9.8	0.164	132.6	3.02	21.1
1.90	0.191	-50.3	10.2	110.1	0.015	7.5	0.148	119.5	3.15	20.1
2.00	0.197	-56.1	9.3	100.8	0.016	5.5	0.137	107.4	3.23	19.4

Note:

1. K factor calculations:

$$K = \frac{1 + |\Delta|^2 - |S_{11}|^2 - |S_{22}|^2}{2 |S_{12} S_{21}|}, \Delta = S_{11} S_{22} - S_{21} S_{12}$$

**EQUIVALENT CIRCUIT**

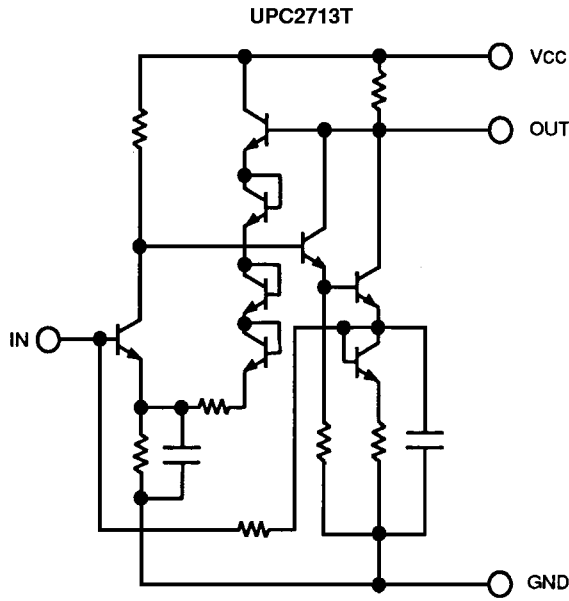
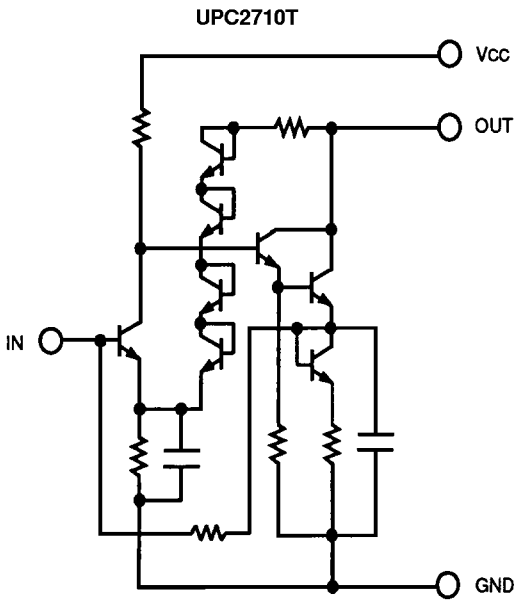

**PACKAGE OUTLINE** (Units in mm)

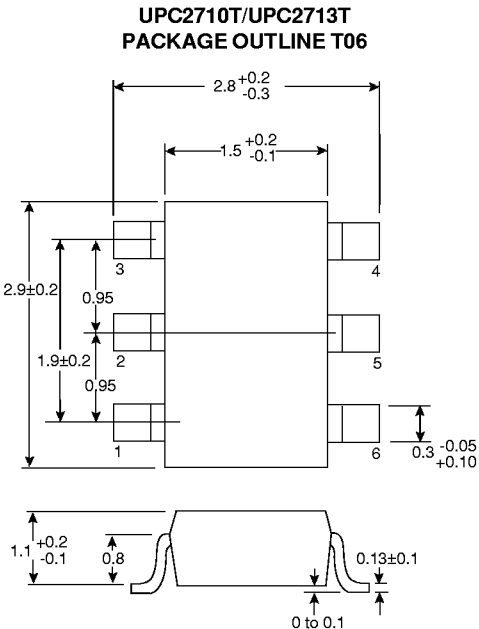

Note:  
All dimensions are typical unless otherwise noted.

**ORDERING INFORMATION**

PART NUMBER	QTY
UPC2710T-E3	3K/Reel
UPC2713T-E3	3K/Reel

Embossed Tape, 8 mm wide.

**LEAD CONNECTIONS**

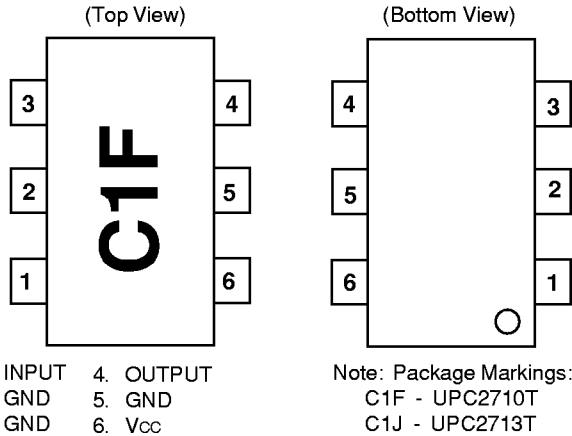

**RECOMMENDED P.C.B. LAYOUT** (Units in mm)

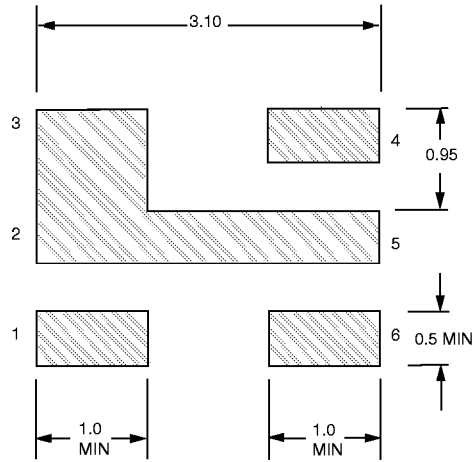

EXCLUSIVE AGENT FOR **NEC Corporation** RF & MICROWAVE SEMICONDUCTOR PRODUCTS - U.S. & CANADA