

SD103AWS / BWS / CWS

List

List.....	1
Package outline.....	2
Features.....	2
Mechanical data.....	2
Maximum ratings and Electrical characteristics	2
Rating and characteristic curves.....	3
Pinning information.....	4
Marking.....	4
Suggested solder pad layout.....	4
Packing information.....	5
Reel packing.....	6
Suggested thermal profiles for soldering processes.....	6
High reliability test capabilities.....	7

SD103AWS / BWS / CWS**350mA Surface Mount Small Signal Schottky Diode-20V-40V****Features**

- Low current rectification and high speed switching
- Extremely small surface mount type
- Low forward voltage drop
- Silicon epitaxial planar chip, metal silicon junction
- Lead-free parts for green partner, exceeds environmental standards of MIL-STD-19500 /228
- Suffix "-H" indicates Halogen-free part, ex. SD103AWS-H

Mechanical data

- Epoxy:UL94-V0 rated flame retardant
- Case : Molded plastic, SOD-323F
- Terminals : Solder plated, solderable per MIL-STD-750, Method 2026
- Polarity : Indicated by cathode band
- Mounting Position : Any
- Weight : Approximated 0.005 gram

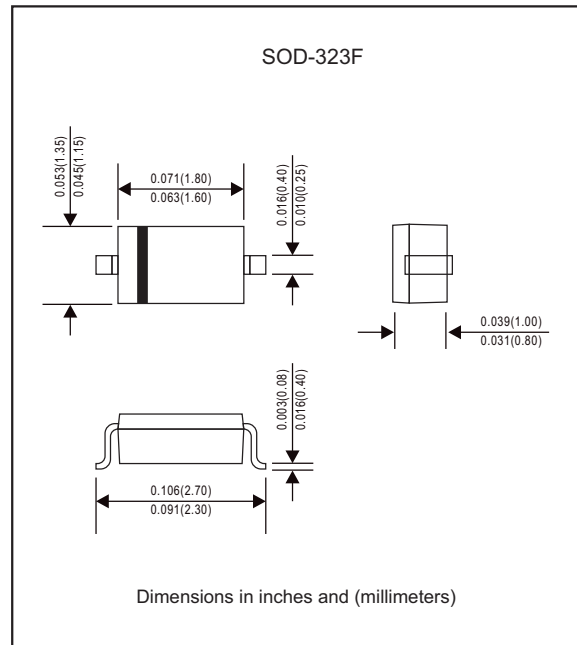
Package outline**Maximum ratings** (AT $T_A=25^\circ\text{C}$ unless otherwise noted)

PARAMETER	CONDITIONS	Symbol	SD103AWS	SD103BWS	SD103CWS	UNIT
Peak repetitive reverse voltage Working peak reverse voltage DC blocking voltage		V_{RRM} V_{RWM} V_R	40	30	20	V
RMS reverse voltage		$V_{R(RMS)}$	28	21	14	V
Average rectified output current		$I_{F(AV)}$	350			mA
Non-repetitive peak forward surge current	@ $t < 1.0s$	I_{FSM}	1.5			A
Total device dissipation		P_D	200			mW
Thermal resistance	Junction to ambient	$R_{\theta JA}$	625			$^\circ\text{C/W}$
Operating junction temperature range		T_J	-55 to +125			$^\circ\text{C}$
Storage temperature range		T_{STG}	-65 to +125			$^\circ\text{C}$

Electrical characteristics (AT $T_A=25^\circ\text{C}$ unless otherwise noted)

PARAMETER	CONDITIONS	Symbol	MIN.	TYP.	MAX.	UNIT
Reverse breakdown voltage	$I_R = 100\mu\text{A}$, SD103AWS $I_R = 100\mu\text{A}$, SD103BWS $I_R = 100\mu\text{A}$, SD103CWS	$V_{(BR)R}$	40 30 20			V
Forward voltage	$I_F = 20\text{mA}$ $I_F = 200\text{mA}$	V_F			0.37 0.60	V
Reverse leakage current	$V_R = 30\text{V}$, SD103AWS $V_R = 20\text{V}$, SD103BWS $V_R = 10\text{V}$, SD103CWS	I_R			5.0	μA
Typical junction capacitance	$V_R = 0\text{V}$, $f = 1.0\text{MHz}$	C_J		50		pF
Reverse recover time	$I_F = I_R = 200\text{mA}$, $I_{tr} = 0.1 \times I_R$, $R_L = 100_{\text{OHM}}$	t_{rr}		10		ns

Rating and characteristic curves (SD103AWS / BWS / CWS)

Fig. 1 POWER DERATING CURVE

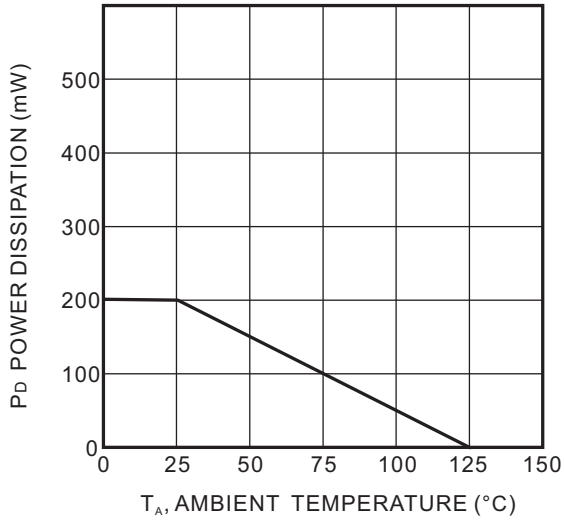

Fig. 2 TYPICAL FORWARD CHARACTERISTIC

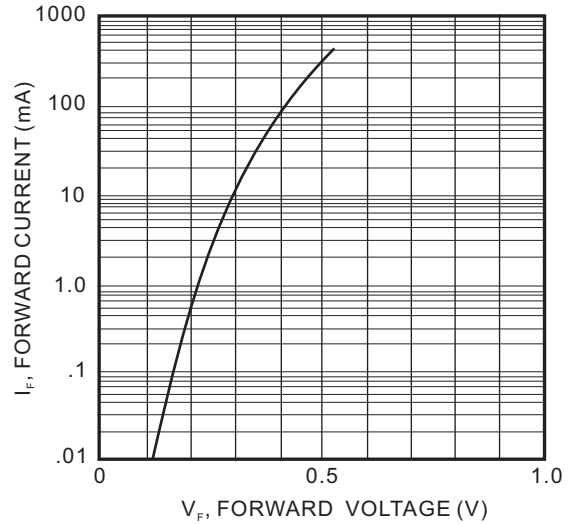
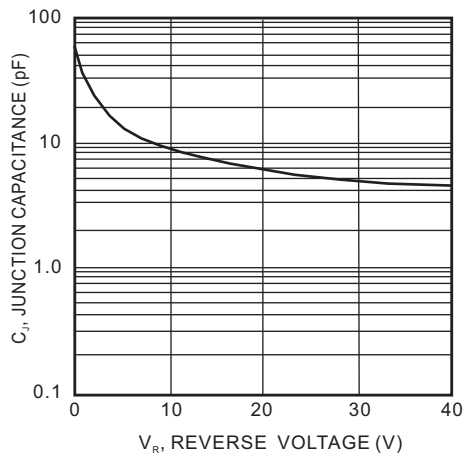



Fig. 3 TYPICAL JUNCTION CAPACITANCE VS REVERSE VOLTAGE



SD103AWS / BWS / CWS

Pinning information

Pin	Simplified outline	Symbol
Pin1 cathode Pin2 anode		

Marking

Type number	Marking code
SD103AWS	S4
SD103BWS	S4, S5
SD103CWS	S4, S6

Suggested solder pad layout

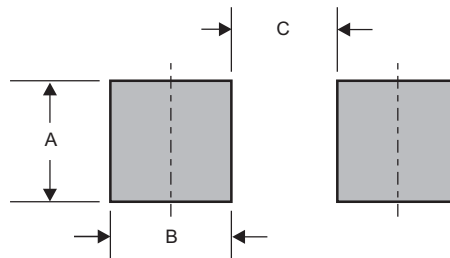

Dimensions in inches and (millimeters)

PACKAGE	A	B	C
SOD-323F	0.033 (0.83)	0.025 (0.63)	0.063 (1.60)

SD103AWS / BWS / CWS

Packing information

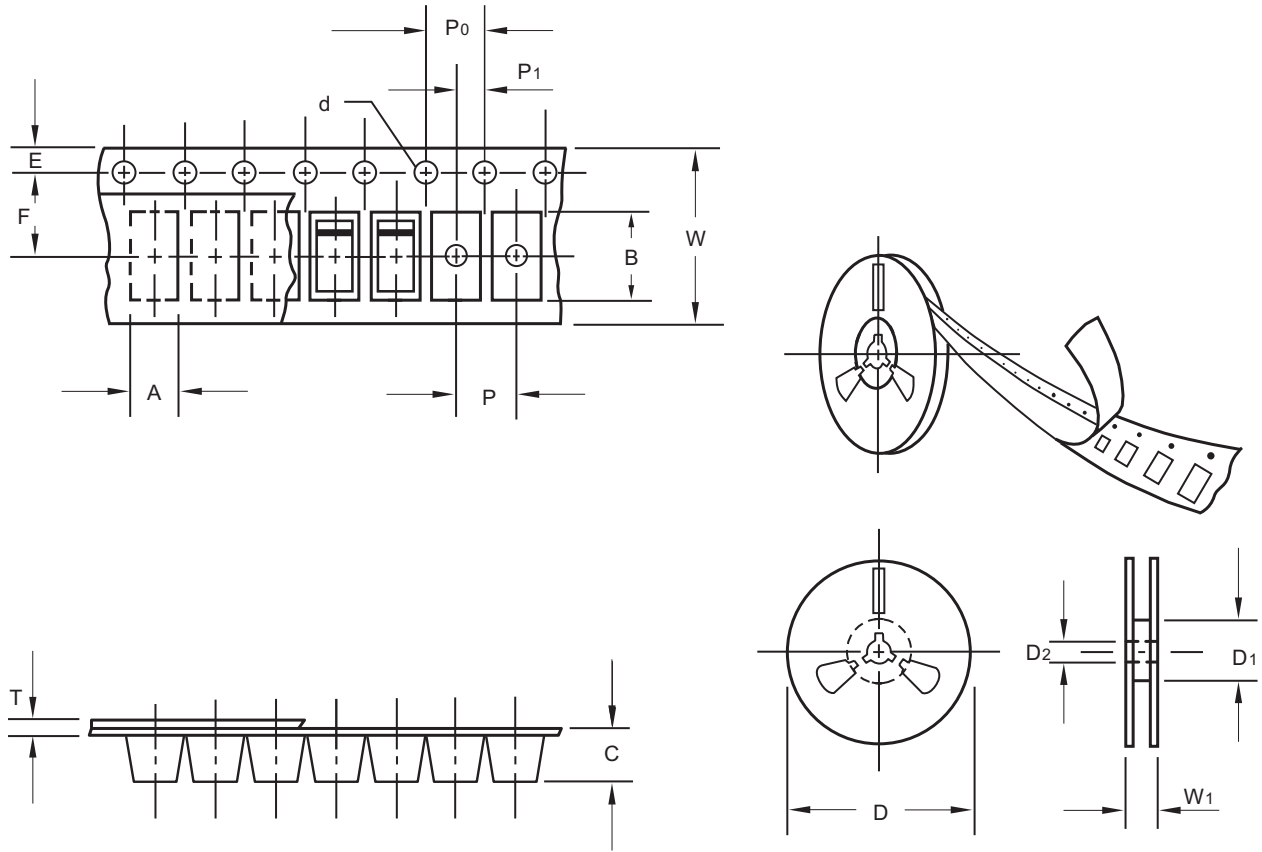

unit:mm

Item	Symbol	Tolerance	SOD-323F
Carrier width	A	0.1	1.46
Carrier length	B	0.1	2.95
Carrier depth	C	0.1	1.25
Sprocket hole	d	0.1	1.50
13" Reel outside diameter	D	2.0	-
13" Reel inner diameter	D1	min	-
7" Reel outside diameter	D	2.0	178.00
7" Reel inner diameter	D1	min	62.00
Feed hole diameter	D2	0.5	13.00
Sprocket hole position	E	0.1	1.75
Punch hole position	F	0.1	3.50
Punch hole pitch	P	0.1	4.00
Sprocket hole pitch	P0	0.1	4.00
Embossment center	P1	0.1	2.00
Overall tape thickness	T	0.1	0.23
Tape width	W	0.3	8.00
Reel width	W1	1.0	11.40

Note: Devices are packed in accordance with EIA standard RS-481-A and specifications listed above.

SD103AWS / BWS / CWS

Reel packing

PACKAGE	REEL SIZE	REEL (pcs)	COMPONENT SPACING (m/m)	BOX (pcs)	INNER BOX (m/m)	REEL DIA, (m/m)	CARTON SIZE (m/m)	CARTON (pcs)	APPROX. GROSS WEIGHT (kg)
SOD-323F	7"	3,000	4.0	30,000	183*123*183	178	382*257*387	240,000	8.0

Suggested thermal profiles for soldering processes

- 1.Storage environment: Temperature=5°C~40°C Humidity=55%±25%
- 2.Reflow soldering of surface-mount devices

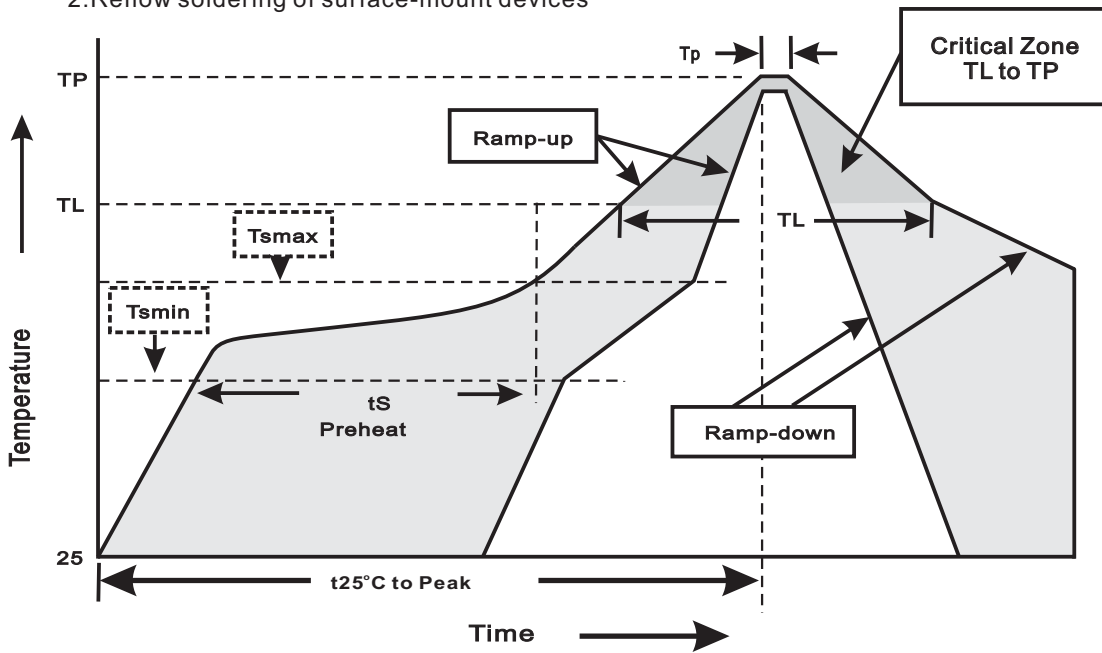

3.Reflow soldering

Profile Feature	Soldering Condition
Average ramp-up rate(T _L to T _P)	<3°C/sec
Preheat -Temperature Min(T _{smin}) -Temperature Max(T _{smax}) -Time(min to max)(t _s)	150°C 200°C 60~120sec
T _{smax} to T _L -Ramp-upRate	<3°C/sec
Time maintained above: -Temperature(T _L) -Time(t _L)	217°C 60~260sec
Peak Temperature(T _P)	255°C-0/+5°C
Time within 5°C of actual Peak Temperature(t _P)	10~30sec
Ramp-down Rate	<6°C/sec
Time 25°C to Peak Temperature	<6minutes

SD103AWS / BWS / CWS**High reliability test capabilities**

Item Test	Conditions	Reference
1. Solder Resistance	at 260±5°C for 10±2sec.	MIL-STD-750D METHOD-2031
2. Solderability	at 245±5°C for 5 sec.	MIL-STD-202F METHOD-208
3. High Temperature Reverse Bias	$V_R=80\%$ rate at $T_J=125^\circ\text{C}$ for 168 hrs.	MIL-STD-750D METHOD-1038
4. Forward Operation Life	Rated average rectifier current at $T_A=25^\circ\text{C}$ for 500hrs.	MIL-STD-750D METHOD-1027
5. Intermittent Operation Life	$T_A = 25^\circ\text{C}$, $I_F = I_O$ On state: power on for 5 min. off state: power off for 5 min. on and off for 500 cycles.	MIL-STD-750D METHOD-1036
6. Pressure Cooker	15P _{SIG} at $T_A=121^\circ\text{C}$ for 4 hrs.	JESD22-A102
7. Temperature Cycling	-55°C to +125°C dwelled for 30 min. and transferred for 5min. total 10 cycles.	MIL-STD-750D METHOD-1051
8. Forward Surge	Non-repetitive peak forward surge current @ $t < 1.0\text{s}$	MIL-STD-750D METHOD-4066-2
9. Humidity	at $T_A=85^\circ\text{C}$, RH=85% for 1000hrs.	MIL-STD-750D METHOD-1021
10. High Temperature Storage Life	at 175°C for 1000 hrs.	MIL-STD-750D METHOD-1031