

## 54AC/74AC352 • 54ACT/74ACT352

### Dual 4-Input Multiplexer

#### Description

The 'AC/ACT352 is a very high-speed dual 4-input multiplexer with common Select inputs and individual Enable inputs for each section. It can select two bits of data from four sources. The two buffered outputs present data in the inverted (complementary) form. The 'AC/ACT352 is the functional equivalent of the 'AC/ACT153 except with inverted outputs.

- Inverted Version of the 'AC/ACT153
- Separate Enables for Each Multiplexer
- Outputs Source/Sink 24 mA
- 'ACT352 has TTL-Compatible Inputs

Ordering Code: See Section 6

#### Logic Symbol

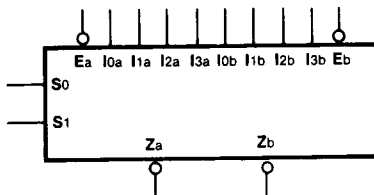

#### Pin Names

- I<sub>0a</sub> - I<sub>3a</sub> Side A Data Inputs
- I<sub>0b</sub> - I<sub>3b</sub> Side B Data Inputs
- S<sub>0</sub>, S<sub>1</sub> Common Select Inputs
- E<sub>a</sub> Side A Enable Input
- E<sub>b</sub> Side B Enable Input
- Z<sub>a</sub>, Z<sub>b</sub> Multiplexer Outputs

#### Connection Diagrams

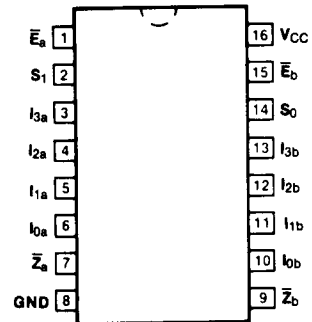

Pin Assignment  
for DIP, Flatpak and SOIC

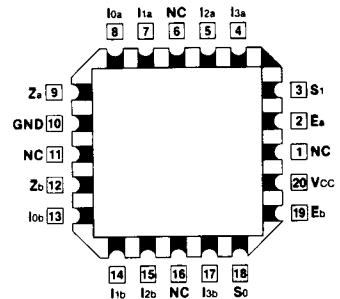

Pin Assignment  
for LCC

### Functional Description

The 'AC/ACT352 is a dual 4-input multiplexer. It selects two bits of data from up to four sources under the control of the common Select inputs ( $S_0$ ,  $S_1$ ). The two 4-input multiplexer circuits have individual active LOW Enables ( $\bar{E}_a$ ,  $\bar{E}_b$ ) which can be used to strobe the outputs independently. When the Enables ( $\bar{E}_a$ ,  $\bar{E}_b$ ) are HIGH, the corresponding outputs ( $\bar{Z}_a$ ,  $\bar{Z}_b$ ) are forced HIGH.

The 'AC/ACT352 can be used to move data from a group of registers to a common output bus. The particular register from which the data came would be determined by the state of the Select inputs. A less obvious application is as a function generator. The 'AC/ACT352 can generate two functions of three variables. This is useful for implementing highly irregular random logic.

The logic equations for the outputs are shown below:

$$\bar{Z}_a = \bar{E}_a \cdot (I_{0a} \cdot \bar{S}_1 \cdot \bar{S}_0 + I_{1a} \cdot \bar{S}_1 \cdot S_0 + I_{2a} \cdot S_1 \cdot \bar{S}_0 + I_{3a} \cdot S_1 \cdot S_0)$$

$$\bar{Z}_b = \bar{E}_b \cdot (I_{0b} \cdot \bar{S}_1 \cdot \bar{S}_0 + I_{1b} \cdot \bar{S}_1 \cdot S_0 + I_{2b} \cdot S_1 \cdot \bar{S}_0 + I_{3b} \cdot S_1 \cdot S_0)$$

**Truth Table**

Select Inputs		Inputs (a or b)					Outputs
$S_0$	$S_1$	$\bar{E}$	$I_0$	$I_1$	$I_2$	$I_3$	$\bar{Z}$
X	X	H	X	X	X	X	H
L	L	L	L	X	X	X	H
L	L	L	H	X	X	X	L
H	L	L	X	L	X	X	H
H	L	L	X	H	X	X	L
L	H	L	X	X	L	X	H
L	H	L	X	X	H	X	L
H	H	L	X	X	X	L	H
H	H	L	X	X	X	H	L

H = HIGH Voltage Level

L = LOW Voltage Level

X = Immaterial

# AC352 • ACT352

## Logic Diagram

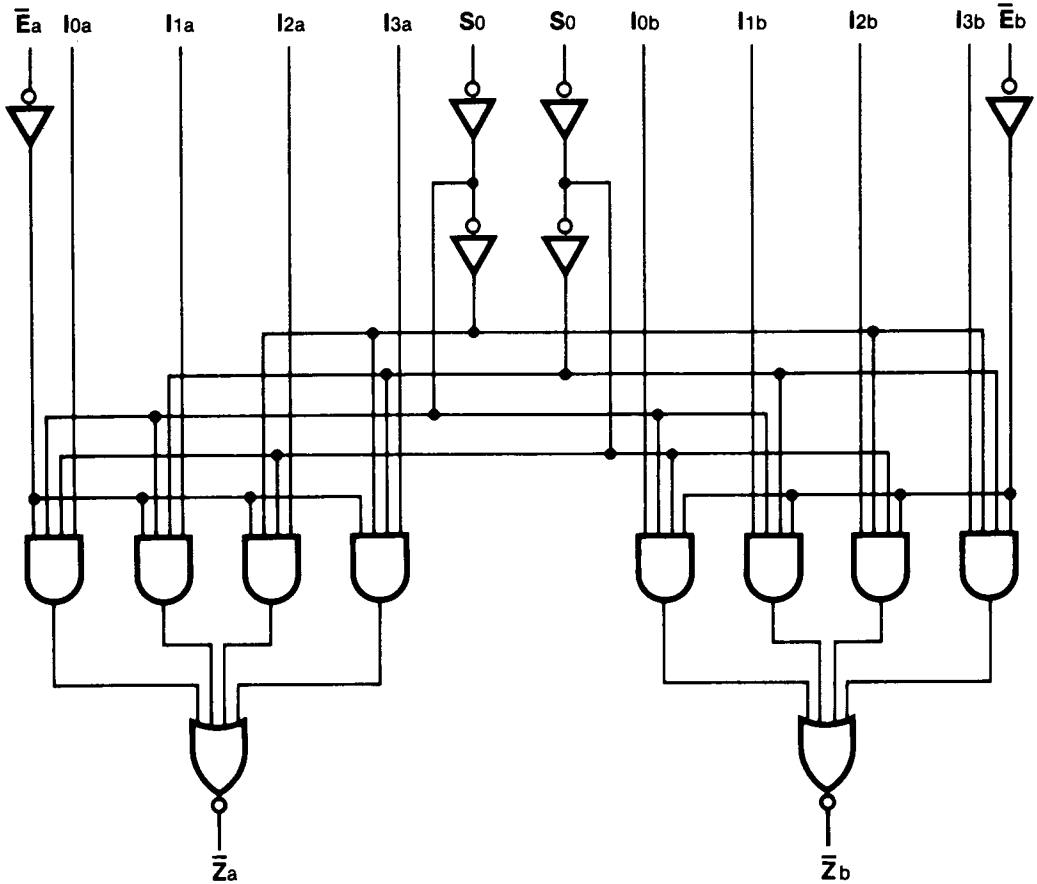

Please note that this diagram is provided only for the understanding of logic operations and should not be used to estimate propagation delays.

### DC Characteristics (unless otherwise specified)

Symbol	Parameter	54AC/ACT	74AC/ACT	Units	Conditions
I <sub>cc</sub>	Maximum Quiescent Supply Current	160	80	μA	V <sub>IN</sub> = V <sub>CC</sub> or Ground, V <sub>CC</sub> = 5.5 V, T <sub>A</sub> = Worst Case
I <sub>cc</sub>	Maximum Quiescent Supply Current	8.0	8.0	μA	V <sub>IN</sub> = V <sub>CC</sub> or Ground, V <sub>CC</sub> = 5.5 V, T <sub>A</sub> = 25°C
I <sub>ccT</sub>	Maximum Additional I <sub>cc</sub> /Input ('ACT352)	1.6	1.5	mA	V <sub>IN</sub> = V <sub>CC</sub> - 2.1 V, V <sub>CC</sub> = 5.5 V, T <sub>A</sub> = Worst Case

## AC Characteristics

Symbol	Parameter	V <sub>CC</sub> * (V)	74AC			54AC		74AC		Units	Fig. No.
			T <sub>A</sub> = +25°C C <sub>L</sub> = 50 pF			T <sub>A</sub> = -55°C to +125°C C <sub>L</sub> = 50 pF		T <sub>A</sub> = -40°C to +85°C C <sub>L</sub> = 50 pF			
			Min	Typ	Max	Min	Max	Min	Max		
t <sub>PLH</sub>	Propagation Delay S <sub>n</sub> to Z <sub>n</sub>	3.3 5.0		9.0 6.5					ns	3-6	
t <sub>PHL</sub>	Propagation Delay S <sub>n</sub> to Z <sub>n</sub>	3.3 5.0		9.0 6.5					ns	3-6	
t <sub>PLH</sub>	Propagation Delay E <sub>n</sub> to Z <sub>n</sub>	3.3 5.0		6.5 5.0					ns	3-6	
t <sub>PHL</sub>	Propagation Delay E <sub>n</sub> to Z <sub>n</sub>	3.3 5.0		6.5 5.0					ns	3-6	
t <sub>PLH</sub>	Propagation Delay I <sub>n</sub> to Z <sub>n</sub>	3.3 5.0		8.5 6.0					ns	3-5	
t <sub>PHL</sub>	Propagation Delay I <sub>n</sub> to Z <sub>n</sub>	3.3 5.0		8.5 6.0					ns	3-5	

\*Voltage Range 3.3 is 3.3 V ± 0.3 V  
Voltage Range 5.0 is 5.0 V ± 0.5 V

Military parameters given herein are for general references only. For current military specifications and subgroup testing information please request Fairchild's Table I data sheet from your Fairchild sales engineer or account representative.

# AC352 • ACT352

## AC Characteristics

Symbol	Parameter	Vcc* (V)	74ACT			54ACT		74ACT		Units	Fig. No.
			TA = +25°C CL = 50 pF			TA = -55°C to +125°C CL = 50 pF		TA = -40°C to +85°C CL = 50 pF			
			Min	Typ	Max	Min	Max	Min	Max		
tPLH	Propagation Delay Sn to Zn	5.0		7.0					ns	3-6	
tPHL	Propagation Delay Sn to Zn	5.0		7.0					ns	3-6	
tPLH	Propagation Delay En to Zn	5.0		5.5					ns	3-6	
tPHL	Propagation Delay En to Zn	5.0		5.5					ns	3-6	
tPLH	Propagation Delay In to Zn	5.0		6.5					ns	3-5	
tPHL	Propagation Delay In to Zn	5.0		6.5					ns	3-5	

\*Voltage Range 5.0 is 5.0 V ± 0.5 V

Military parameters given herein are for general references only. For current military specifications and subgroup testing information please request Fairchild's Table I data sheet from your Fairchild sales engineer or account representative.

## Capacitance

Symbol	Parameter	54/74AC/ACT	Units	Conditions
		Typ		
CIN	Input Capacitance	4.5	pF	Vcc = 5.5 V
CPD	Power Dissipation Capacitance		pF	Vcc = 5.5 V