

**Document Title****512Kx8 bit Low Power CMOS Static RAM****Revision History**

<b><u>Revision No.</u></b>	<b><u>History</u></b>	<b><u>Draft Date</u></b>	<b><u>Remark</u></b>
0.0	Initial draft	October 20, 1998	Preliminary
1.0	Finalize	April 12, 1999	Final

---

The attached datasheets are provided by SAMSUNG Electronics. SAMSUNG Electronics CO., LTD. reserve the right to change the specifications and products. SAMSUNG Electronics will answer to your questions about device. If you have any questions, please contact the SAMSUNG branch offices.

---

## 512Kx8 bit Low Power CMOS Static RAM

### FEATURES

- Process Technology: TFT
- Organization: 512Kx8
- Power Supply Voltage: 4.5~5.5V
- Low Data Retention Voltage: 2V(Min)
- Three state output and TTL Compatible
- Package Type: 32-DIP-600, 32-SOP-525, 32-TSOP2-400F/R

### GENERAL DESCRIPTION

The KM684000C families are fabricated by SAMSUNG's advanced CMOS process technology. The families support various operating temperature ranges and various package types for user flexibility of system design. The family also support low data retention voltage for battery back-up operation with low data retention current.

### PRODUCT FAMILY

Product Family	Operating Temperature	Vcc Range	Speed	Power Dissipation		PKG Type
				Standby (I <sub>sb1</sub> , Max)	Operating (I <sub>cc2</sub> , Max)	
KM684000CL	Commercial (0~70°C)	4.5~5.5V	55 <sup>1)</sup> /70ns	80μA	55mA	32-DIP, 32-SOP 32-TSOP2-F/R
KM684000CL-L				20μA		
KM684000CLI	Industrial (-40~85°C)			100μA		
KM684000CLI-L				30μA		32-SOP 32-TSOP2-F/R

1. The parameter is measured with 50pF test load.

### PIN DESCRIPTION

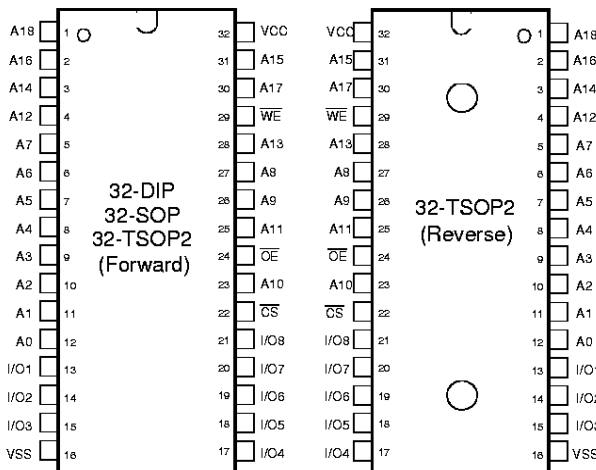

Pin Name	Function
$\overline{WE}$	Write Enable Input
$\overline{CS}$	Chip Select Input
$\overline{OE}$	Output Enable Input
A0~A18	Address Inputs
I/O1~I/O8	Data Inputs/Outputs
Vcc	Power
Vss	Ground

### FUNCTIONAL BLOCK DIAGRAM

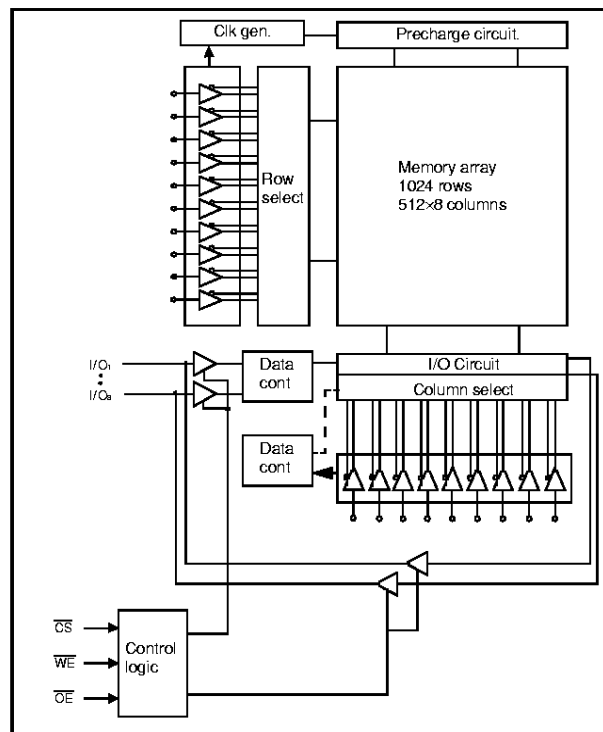

SAMSUNG ELECTRONICS CO., LTD. reserves the right to change products and specifications without notice.

## PRODUCT LIST

Commercial Temperature Products(0~70°C)		Industrial Temperature Products(-40~85°C)	
Part Name	Function	Part Name	Function
KM684000CLP-5	32-DIP, 55ns, Low Power	KM684000CLGI-5	32-SOP, 55ns, Low Power
KM684000CLP-5L	32-DIP, 55ns, Low Low Power	KM684000CLGI-5L	32-SOP, 55ns, Low Low Power
KM684000CLP-7	32-DIP, 70ns, Low Power	KM684000CLGI-7	32-SOP, 70ns, Low Power
KM684000CLP-7L	32-DIP, 70ns, Low Low Power	KM684000CLGI-7L	32-SOP, 70ns, Low Low Power
KM684000CLG-5	32-SOP, 55ns, Low Power	KM684000CLTI-5L	32-TSOP2-F, 55ns, Low Low Power
KM684000CLG-5L	32-SOP, 55ns, Low Low Power	KM684000CLTI-7L	32-TSOP2-F, 70ns, Low Low Power
KM684000CLG-7	32-SOP, 70ns, Low Power	KM684000CLRI-5L	32-TSOP2-R, 55ns, Low Low Power
KM684000CLG-7L	32-SOP, 70ns, Low Low Power	KM684000CLRI-7L	32-TSOP2-R, 70ns, Low Low Power
KM684000CLT-5L	32-TSOP2-F, 55ns, Low Low Power		
KM684000CLT-7L	32-TSOP2-F, 70ns, Low Low Power		
KM684000CLR-5L	32-TSOP2-R, 55ns, Low Low Power		
KM684000CLR-7L	32-TSOP2-R, 70ns, Low Low Power		

## FUNCTIONAL DESCRIPTION

CS	OE	WE	I/O Pin	Mode	Power
H	X <sup>1)</sup>	X <sup>1)</sup>	High-Z	Deselected	Standby
L	H	H	High-Z	Output disbaled	Active
L	L	H	Dout	Read	Active
L	X <sup>1)</sup>	L	Din	Write	Active

1. X means don't care.( Must be in low or high state.)

## ABSOLUTE MAXIMUM RATINGS<sup>1)</sup>

Item	Symbol	Ratings	Unit	Remark
Voltage on any pin relative to Vss	V <sub>IN</sub> ,V <sub>OUT</sub>	-0.5 to 7.0	V	-
Voltage on Vcc supply relative to Vss	V <sub>CC</sub>	-0.5 to 7.0	V	-
Power Dissipation	P <sub>D</sub>	1.0	W	-
Storage temperature	T <sub>STG</sub>	-65 to 150	°C	-
Operating Temperature	T <sub>A</sub>	0 to 70	°C	KM684000CL/L-L
		-40 to 85	°C	KM684000CLI/LI-L

1. Stresses greater than those listed under "Absolute Maximum Ratings" may cause permanent damage to the device. Functional operation should be restricted to recommended operating condition. Exposure to absolute maximum rating conditions for extended periods may affect reliability.

## RECOMMENDED DC OPERATING CONDITIONS<sup>1)</sup>

Item	Symbol	Min	Typ	Max	Unit
Supply voltage	V <sub>CC</sub>	4.5	5.0	5.5	V
Ground	V <sub>SS</sub>	0	0	0	V
Input high voltage	V <sub>IH</sub>	2.2	-	V <sub>CC</sub> +0.5 <sup>2)</sup>	V
Input low voltage	V <sub>IL</sub>	-0.5 <sup>3)</sup>	-	0.8	V

Note:

- Commercial Product : T<sub>A</sub>=0 to 70°C, otherwise specified  
Industrial Product : T<sub>A</sub>=-40 to 85°C, otherwise specified
- Overshoot : V<sub>CC</sub>+3.0V in case of pulse width ≤ 30ns
- Undershoot : -3.0V in case of pulse width ≤ 30ns
- Overshoot and undershoot are sampled, not 100% tested.

## CAPACITANCE<sup>1)</sup> (f=1MHz, T<sub>A</sub>=25°C)

Item	Symbol	Test Condition	Min	Max	Unit
Input capacitance	C <sub>IN</sub>	V <sub>IN</sub> =0V	-	8	pF
Input/Output capacitance	C <sub>IO</sub>	V <sub>IO</sub> =0V	-	10	pF

- Capacitance is sampled, not 100% tested

## DC AND OPERATING CHARACTERISTICS

Item	Symbol	Test Conditions	Min	Typ	Max	Unit	
Input leakage current	I <sub>LI</sub>	V <sub>IN</sub> =V <sub>SS</sub> to V <sub>CC</sub>	-1	-	1	μA	
Output leakage current	I <sub>LO</sub>	$\overline{CS}$ =V <sub>IH</sub> or $\overline{OE}$ =V <sub>IH</sub> or $\overline{WE}$ =V <sub>IL</sub> , V <sub>IO</sub> =V <sub>SS</sub> to V <sub>CC</sub>	-1	-	1	μA	
Operating power supply current	I <sub>CC</sub>	I <sub>IO</sub> =0mA, $\overline{CS}$ =V <sub>IL</sub> , V <sub>IN</sub> =V <sub>IL</sub> or V <sub>IH</sub> , Read	-	-	10	mA	
Average operating current	I <sub>CC1</sub>	Cycle time=1μs, 100% duty, I <sub>IO</sub> =0mA $\overline{CS}$ ≤0.2V, V <sub>IN</sub> ≥0.2V or V <sub>IN</sub> ≥V <sub>CC</sub> -0.2V	-	-	8	mA	
	I <sub>CC2</sub>	Cycle time=Min, 100% duty, I <sub>IO</sub> =0mA, $\overline{CS}$ =V <sub>IL</sub> , V <sub>IN</sub> =V <sub>IH</sub> or V <sub>IL</sub>	-	-	55	mA	
Output low voltage	V <sub>OL</sub>	I <sub>OL</sub> =2.1mA	-	-	0.4	V	
Output high voltage	V <sub>OH</sub>	I <sub>OH</sub> =-1.0mA	2.4	-	-	V	
Standby Current(TTL)	I <sub>SB</sub>	$\overline{CS}$ =V <sub>IH</sub> , Other inputs = V <sub>IL</sub> or V <sub>IH</sub>	-	-	3	mA	
Standby Current(CMOS)	I <sub>SB1</sub>	$\overline{CS}$ ≥V <sub>CC</sub> -0.2V, Other inputs=0~V <sub>CC</sub>	KM684000CL	-	-	80	μA
			KM684000CL-L	-	-	20	
			KM684000CLI	-	-	100	
			KM684000CLI-L	-	-	30	

## AC OPERATING CONDITIONS

### TEST CONDITIONS (Test Load and Test Input/Output Reference)

Input pulse level : 0.8 to 2.4V  
 Input rising and falling time : 5ns  
 Input and output reference voltage : 1.5V  
 Output load (See right) :  $C_L = 100\text{pF} + 1\text{TTL}$   
 $C_L = 50\text{pF} + 1\text{TTL}$

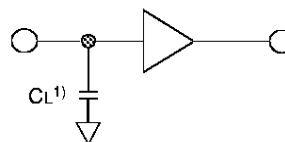

1. Including scope and jig capacitance

## AC CHARACTERISTICS ( $V_{CC} = 4.5 \sim 5.5\text{V}$ , KM684000C Family: $T_A = 0$ to $70^\circ\text{C}$ , KM684000CI Family: $T_A = -40$ to $85^\circ\text{C}$ )

Parameter List		Symbol	Speed Bins				Units
			55ns		70ns		
			Min	Max	Min	Max	
Read	Read cycle time	$t_{RC}$	55	-	70	-	ns
	Address access time	$t_{AA}$	-	55	-	70	ns
	Chip select to output	$t_{CO}$	-	55	-	70	ns
	Output enable to valid output	$t_{OE}$	-	25	-	35	ns
	Chip select to low-Z output	$t_{LZ}$	10	-	10	-	ns
	Output enable to low-Z output	$t_{OLZ}$	5	-	5	-	ns
	Chip disable to high-Z output	$t_{HZ}$	0	20	0	25	ns
	Output disable to high-Z output	$t_{OHZ}$	0	20	0	25	ns
	Output hold from address change	$t_{OH}$	10	-	10	-	ns
Write	Write cycle time	$t_{WC}$	55	-	70	-	ns
	Chip select to end of write	$t_{CW}$	45	-	60	-	ns
	Address set-up time	$t_{AS}$	0	-	0	-	ns
	Address valid to end of write	$t_{AW}$	45	-	60	-	ns
	Write pulse width	$t_{WP}$	40	-	50	-	ns
	Write recovery time	$t_{WR}$	0	-	0	-	ns
	Write to output high-Z	$t_{WHZ}$	0	20	0	25	ns
	Data to write time overlap	$t_{DW}$	25	-	30	-	ns
	Data hold from write time	$t_{DH}$	0	-	0	-	ns
	End write to output low-Z	$t_{OW}$	5	-	5	-	ns

## DATA RETENTION CHARACTERISTICS

Item	Symbol	Test Condition	Min	Typ	Max	Unit	
$V_{CC}$ for data retention	VDR	$\overline{CS} \geq V_{CC} - 0.2\text{V}$	2.0	-	5.5	V	
Data retention current	IDR	$V_{CC} = 3.0\text{V}, \overline{CS} \geq V_{CC} - 0.2\text{V}$	KM684000CL	-	-	40	$\mu\text{A}$
			KM684000CL-L	-	-	15	
			KM684000CLI	-	-	50	
			KM684000CLI-L	-	-	20	
Data retention set-up time	$t_{SDR}$	See data retention waveform	0	-	-	ms	
Recovery time	$t_{RDR}$		5	-	-		

TIMMING DIAGRAMS

TIMING WAVEFORM OF READ CYCLE(1) (Address Controlled,  $\overline{CS}=\overline{OE}=V_{IL}$ ,  $\overline{WE}=V_{IH}$ )

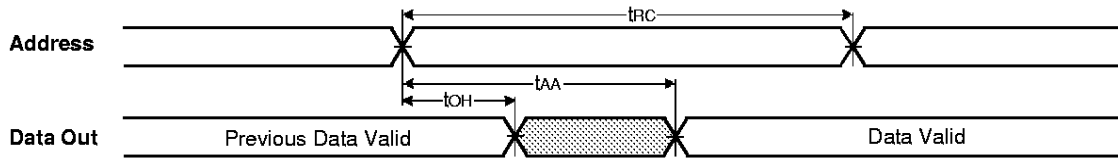

TIMING WAVEFORM OF READ CYCLE(2) ( $\overline{WE}=V_{IH}$ )

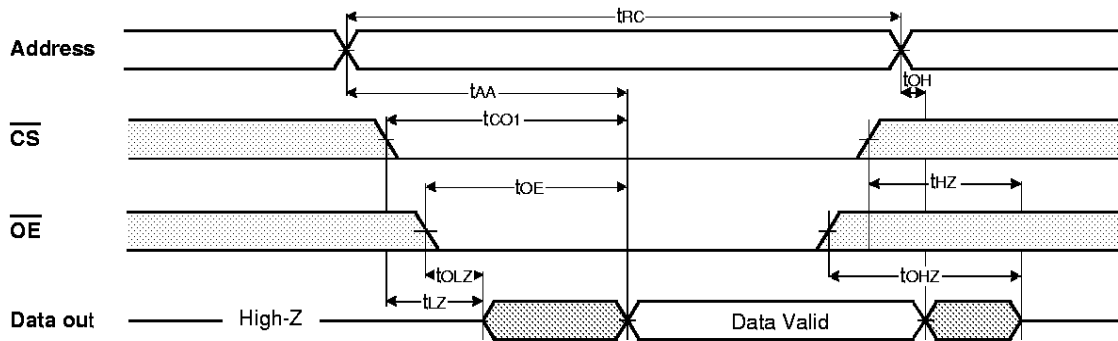

NOTES (READ CYCLE)

1.  $t_{HZ}$  and  $t_{OHZ}$  are defined as the time at which the outputs achieve the open circuit conditions and are not referenced to output voltage levels.
2. At any given temperature and voltage condition,  $t_{HZ}(\text{Max.})$  is less than  $t_{LZ}(\text{Min.})$  both for a given device and from device to device interconnection.

**TIMING WAVEFORM OF WRITE CYCLE(1) (WE Controlled)**

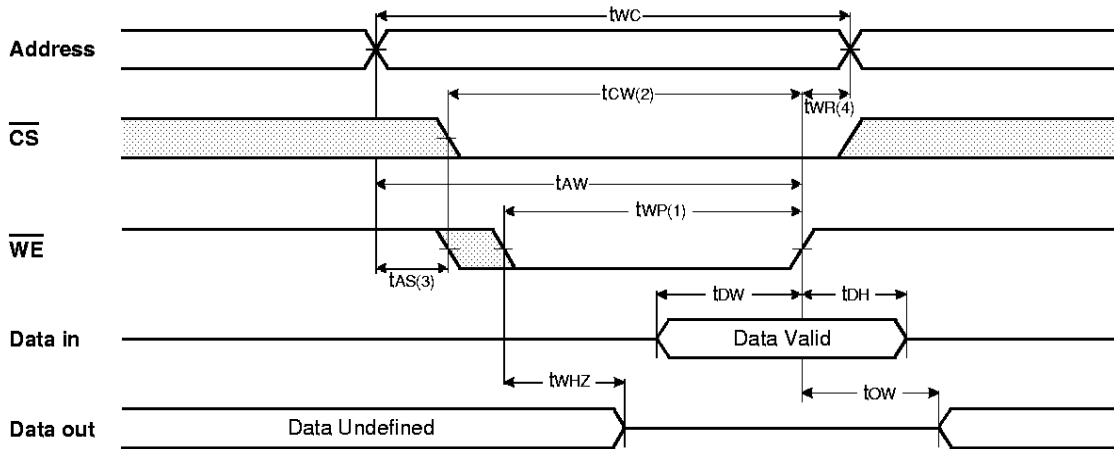

**TIMING WAVEFORM OF WRITE CYCLE(2) ( $\overline{CS}$  Controlled)**

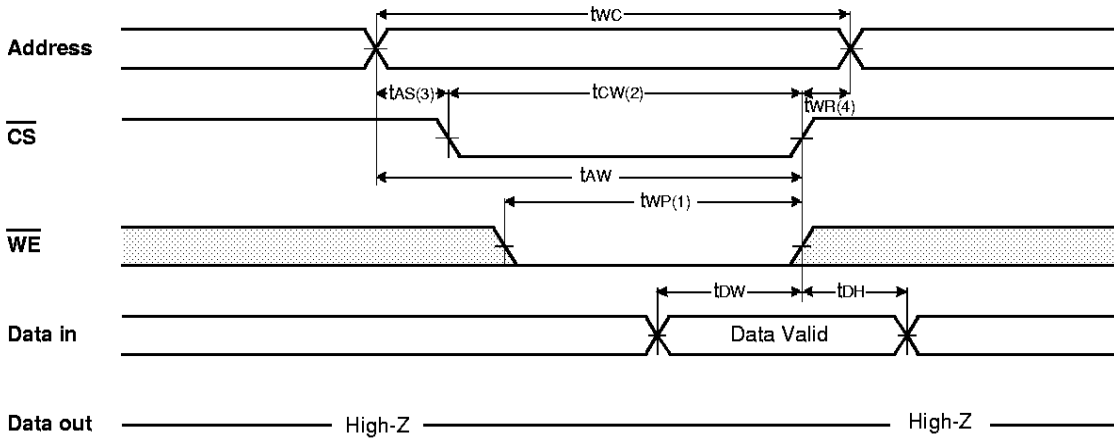

**NOTES (WRITE CYCLE)**

1. A write occurs during the overlap of a low  $\overline{CS}$  and a low  $\overline{WE}$ . A write begins at the latest transition among  $\overline{CS}$  going Low and  $\overline{WE}$  going low. A write ends at the earliest transition among  $\overline{CS}$  going high and  $\overline{WE}$  going high,  $t_{WP}$  is measured from the beginning of write to the end of write.
2.  $t_{OW}$  is measured from the  $\overline{CS}$  going low to end of write.
3.  $t_{AS}$  is measured from the address valid to the beginning of write.
4.  $t_{WR}$  is measured from the end of write to the address change.  $t_{WR}$  applied in case a write ends as  $\overline{CS}$  or  $\overline{WE}$  going high.

**DATA RETENTION WAVE FORM**

$\overline{CS}$  controlled

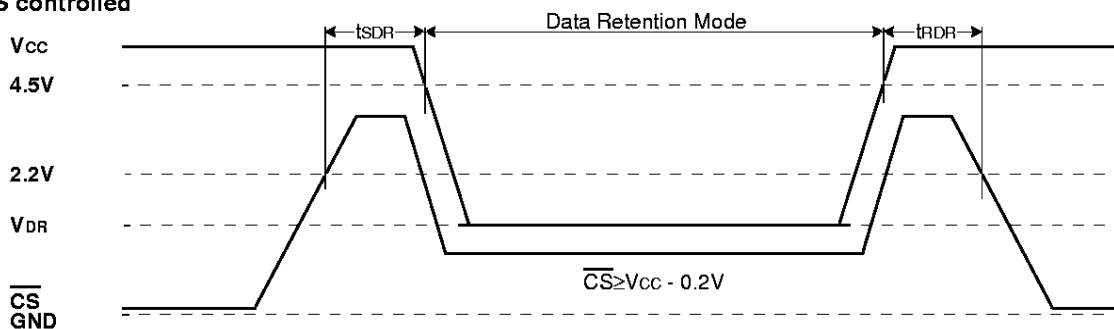

## PACKAGE DIMENSIONS

Units : millimeter(Inch)

### 32 PIN DUAL INLINE PACKAGE (600mil)

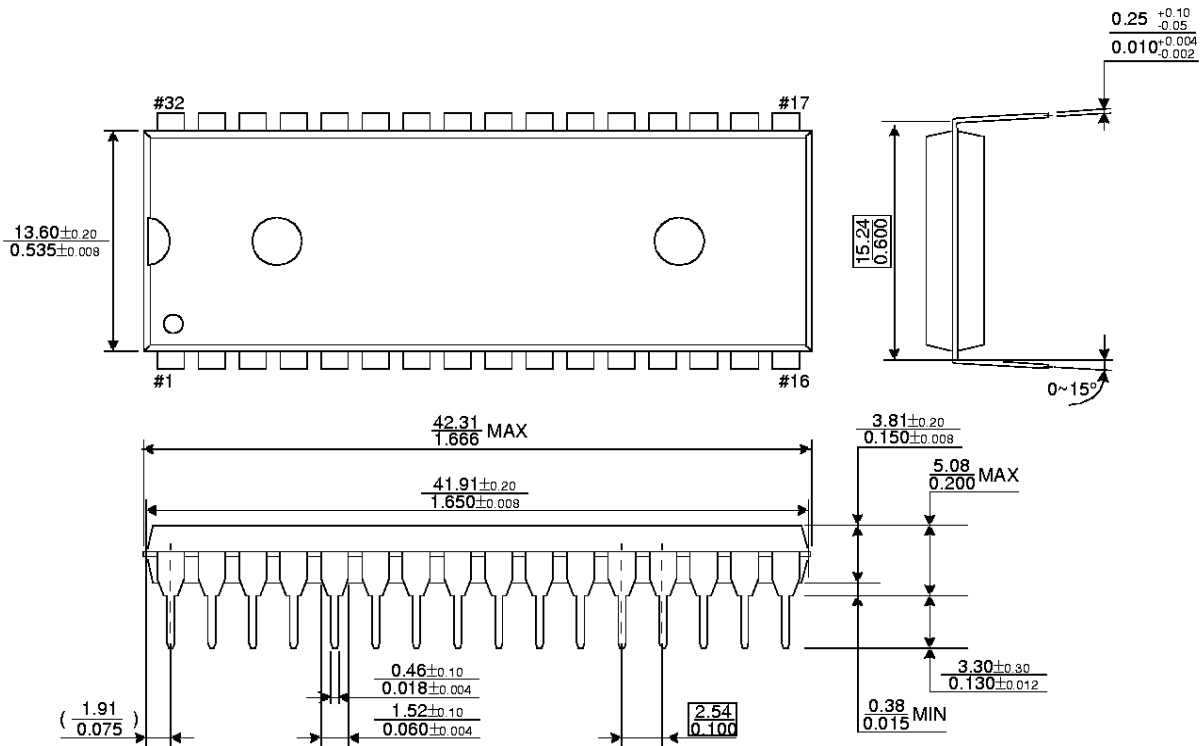

### 32 PIN PLASTIC SMALL OUTLINE PACKAGE (525mil)

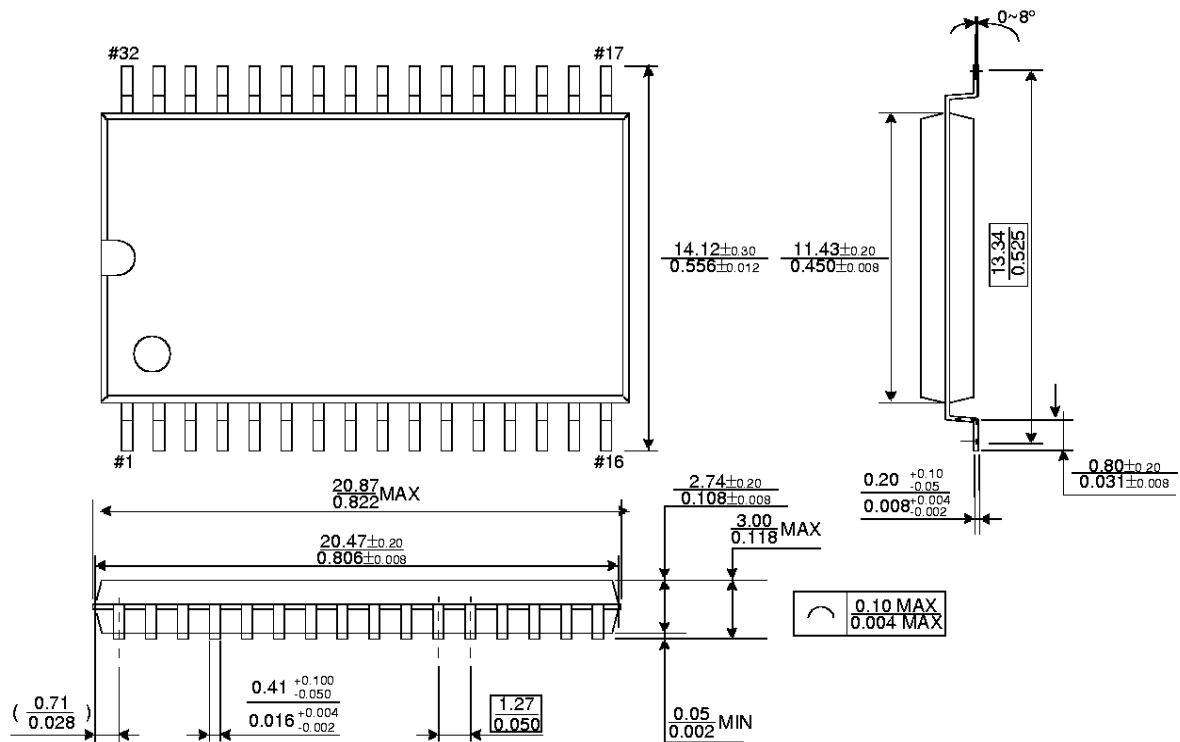



## PACKAGE DIMENSIONS

Units : millimeter(Inch)

### 32 PIN THIN SMALL OUTLINE PACKAGE TYPE II (400F)

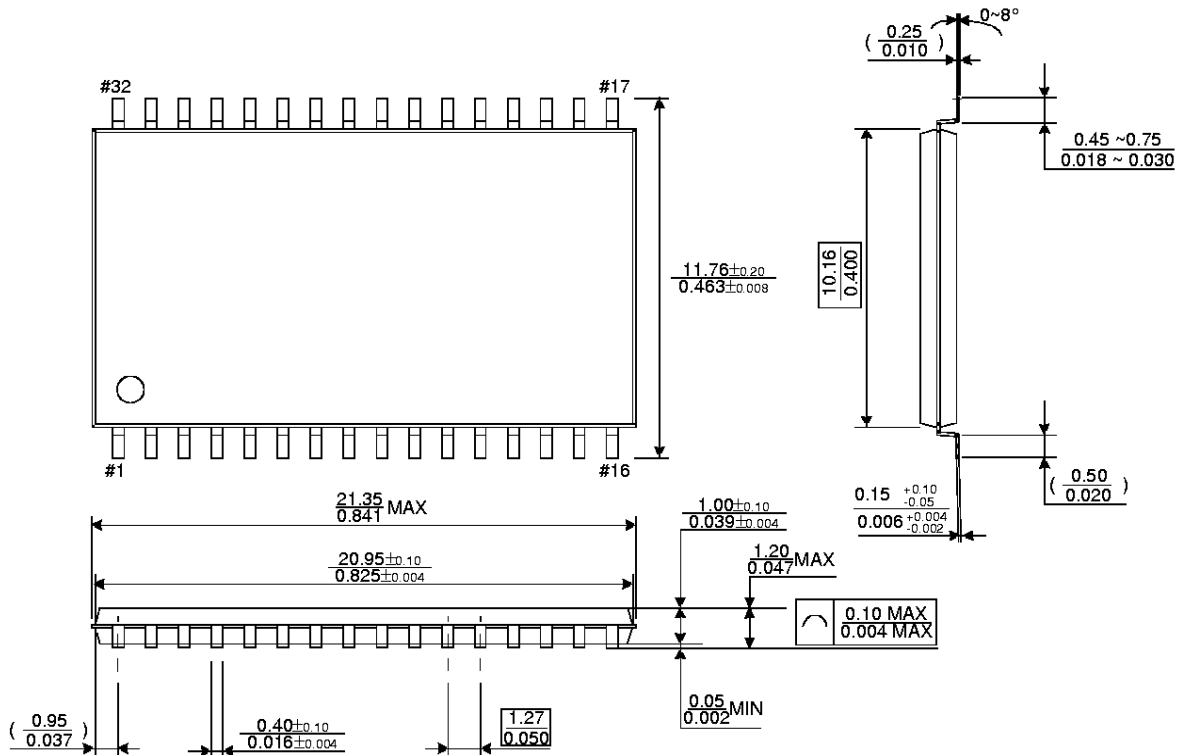

### 32 PIN THIN SMALL OUTLINE PACKAGE TYPE II (400R)

