



Quad 2-Input Data Selector/Multiplexer with Enable

**ELECTRICALLY TESTED PER:
MIL-M-38510/30903**

The LS TTL/MSI 54LS157 is a high-speed Quad 2-Input Multiplexer. Four bits of data from two sources can be selected using the common Select and Enable inputs. The four buffered outputs present the selected data in the true (non-inverted) form. The 'LS157 can also be used to generate any four of the 16 different functions of two variables. The 'LS157 is fabricated with the Schottky barrier diode process for high speed and is completely compatible with all Motorola TTL families.

- Schottky Process For High-Speed
- Multifunction Capability
- Non-Inverting Outputs
- Input Clamp Diodes Limit High-Speed Termination Effects

CONNECTION DIAGRAM

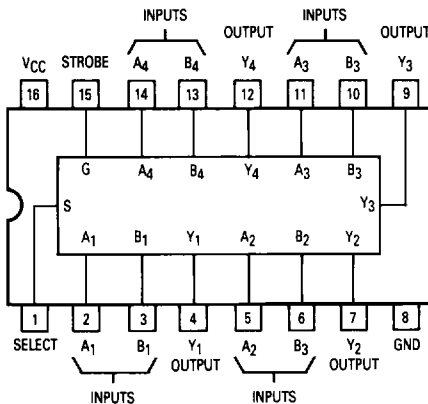

Military 54LS157



AVAILABLE AS:

- 1) JAN: JM38510/30903BXA
- 2) SMD: 7600201
- 3) 883C: 54LS157/BXAJC

**X = CASE OUTLINE AS FOLLOWS:
PACKAGE: CERDIP: E
CERFLAT: F
LCC: 2**

*Call Factory for latest update

PIN ASSIGNMENTS

FUNCTION	DIL	FLATS	LCC	BURN-IN (CONDITION A)
S	1	1	2	GND
A ₁	2	2	3	VCC
B ₁	3	3	4	VCC
Y ₁	4	4	5	VCC
A ₂	5	5	7	VCC
B ₂	6	6	8	VCC
Y ₂	7	7	9	VCC
GND	8	8	10	GND
Y ₃	9	9	12	VCC
B ₃	10	10	13	VCC
A ₃	11	11	14	VCC
Y ₄	12	12	15	VCC
B ₄	13	13	17	VCC
A ₄	14	14	18	VCC
G	15	15	19	GND
VCC	16	16	20	VCC

**BURN-IN CONDITIONS:
VCC = 5.0 V MIN/6.0 V MAX**

TRUTH TABLE

Enable	Select Inputs	Inputs		Output
G	S	A	B	Y
H	X	X	X	L
L	H	X	L	L
L	H	X	H	H
L	L	L	X	L
L	L	H	X	H

H = HIGH Voltage Level
L = LOW Voltage Level
X = Don't Care

54LS157

FUNCTIONAL DESCRIPTION

The 'LS157 is a Quad 2-Input Multiplexer fabricated with the Schottky barrier diode process for high speed. It selects four bits of data from two sources under the control of a common Select Input (S). The Enable Input (G) is Active LOW. When G is HIGH, all of the outputs (Y) are forced LOW regardless of all other inputs.

The 'LS157 is the logic implementation of a 4-pole, 2-position switch where the position of the switch is determined by the logic levels supplied to the Select Input. The logic equations for the outputs are shown below:

$$Y_1 = G \cdot (A_1 \cdot S + B_1 \cdot \bar{S}) \quad Y_2 = G \cdot (A_2 \cdot S + B_2 \cdot \bar{S})$$

$$Y_3 = G \cdot (A_3 \cdot S + B_3 \cdot \bar{S}) \quad Y_4 = G \cdot (A_4 \cdot S + B_4 \cdot \bar{S})$$

A common use of the 'LS157 is the moving of data from two groups of registers to four common output busses. The particular register from which the data comes is determined by the state of the Select Input. A less obvious use is as a function generator. The 'LS157 can generate any four of the 16 different functions of two variables with one variable common. This is useful for implementing highly irregular logic.

Pin Names	Loading (Note a)	Loading (Note a)	
		HIGH	LOW
S Common Select Input		1.0 U.L.	0.5 U.L.
G Enable (Active LOW) Input		1.0 U.L.	0.5 U.L.
A ₁ -A ₄ Data Inputs from Source 0		0.5 U.L.	0.25 U.L.
B ₁ -B ₄ Data Inputs from Source 1		0.5 U.L.	0.25 U.L.
Y ₁ -Y ₄ Multiplexer Outputs (Note b)		10 U.L.	5(2.5) U.L.

NOTES:

- a. One TTL Unit Load (U.L.) = 40 μ A HIGH; 1.6 mA LOW.
- b. The Output LOW drive factor is 2.5 U.L. for Military (54) Temperature Ranges.

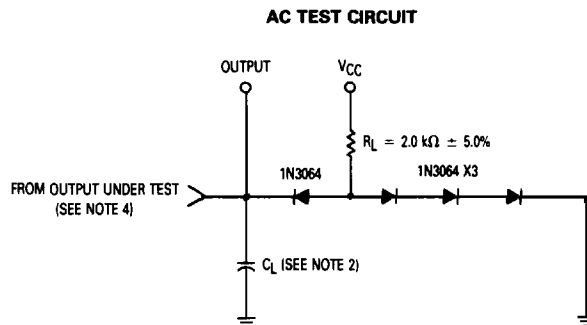

WAVEFORMS

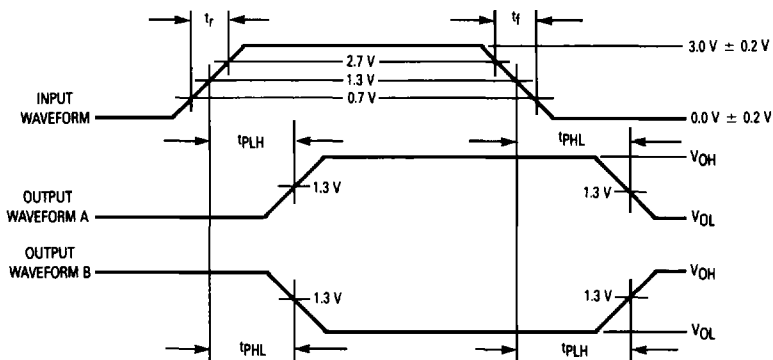

NOTES:

1. Input pulse generator has the following characteristics:
 $t_r \leq 15$ ns, $t_f \leq 6.0$ ns, PRR ≤ 1.0 MHz.
2. $C_L = 50$ pF $\pm 10\%$, including scope probe and jig capacitance.
3. $R_L = 2.0$ k Ω $\pm 5.0\%$. All diodes are 1N3064 or 1N916.
4. Load circuit on a given output is only required where the specific test in table 1 indicates "OUT" on that output.
5. Voltage measurements are to be made with respect to network ground terminal.

54LS157

Symbol	Parameter	Limits						Units	Test Condition (Unless Otherwise Specified)
		+ 25°C		+ 125°C		- 55°C			
		Subgroup 1		Subgroup 2		Subgroup 3			
		Min	Max	Min	Max	Min	Max		
V _{OH}	Logical "1" Output Voltage	2.5		2.5		2.5		V	V _{CC} = 4.5 V, I _{OH} = -0.4 mA, V _{IH} = 2.0 V, S = 2.0 V, G = 0.7 V.
V _{OL}	Logical "0" Output Voltage		0.4		0.4		0.4	V	V _{CC} = 4.5 V, I _{OL} = 4.0 mA, G = 2.0 V, other inputs are open.
V _{IC}	Input Clamping Voltage		- 1.5					V	V _{CC} = 4.5 V, I _{IN} = - 18 mA, other inputs are open.
I _{IH1}	Logical "1" Input Current		20		20		20	μA	V _{CC} = 5.5 V, V _{IH} = 2.7 V, other inputs are open, S = 5.5 V or GND.
I _{IHH1}	Logical "1" Input Current		100		100		100	μA	V _{CC} = 5.5 V, S = 5.5 V or GND, other inputs are open.
I _{IH2}	Logical "1" Input Current		40		40		40	μA	V _{CC} = 5.5 V, S & G = 2.7 V or GND, other inputs are open.
I _{IHH2}	Logical "1" Input Current		200		200		200	μA	V _{CC} = 5.5 V, S & G = 5.5 V or GND, other inputs are open.
I _{IL}	Logical "0" Input Current	-0.16	-0.4	-0.16	-0.4	-0.16	-0.4	mA	V _{CC} = 5.5 V, V _{IN} = 0.4 V, other input = 5.5 V, S = GND or 5.5 V, G = GND.
I _{IL(S)}	Logical "0" Input Current	-0.23	-0.71	-0.23	-0.71	-0.23	-0.71	mA	V _{CC} = 5.5 V, S = 0.4 V, G = 5.5 V, other inputs are open.
I _{IL(G)}	Logical "0" Input Current	-0.32	-0.8	-0.32	-0.8	-0.32	-0.8	mA	V _{CC} = 5.5 V, S = 5.5 V, G = 0.4 V, other inputs are open.
I _{OS}	Output Short Circuit Current	- 15	- 100	- 15	- 100	- 15	- 100	mA	V _{CC} = 5.5 V, V _{IN} = 5.5 V, S & G = GND, V _{OUT} = 0 V, other inputs are open.
I _{CC}	Power Supply Current		16		16		16	mA	V _{CC} = 5.5 V, V _{IN} = 5.5 V (all inputs).
V _{IH}	Logical "1" Input Voltage	2.0		2.0		2.0		V	V _{CC} = 4.5 V.
V _{IL}	Logical "0" Input Voltage		0.7		0.7		0.7	V	V _{CC} = 4.5 V.
	Functional Tests	Subgroup 7		Subgroup 8A		Subgroup 8B			per Truth Table with V _{CC} = 5.0 V, V _{INL} = 0.4 V, and V _{IINH} = 2.5 V.

54LS157

Symbol	Parameter	Limits						Units	Test Condition (Unless Otherwise Specified)
		+ 25°C		+ 125°C		- 55°C			
		Subgroup 9		Subgroup 10		Subgroup 11			
		Min	Max	Min	Max	Min	Max		
tPHL1 tPHL1	Propagation Delay Data-Output Data to Output	3.0	19	3.0	29	3.0	29	ns ns	V _{CC} = 5.0 V, C _L = 50 pF, R _L = 2.0 kΩ. V _{CC} = 5.0 V, C _L = 15 pF, R _L = 2.0 kΩ.
tPLH1 tPLH1	Propagation Delay Data-Output Data to Output	3.0	19	3.0	29	3.0	29	ns ns	V _{CC} = 5.0 V, C _L = 50 pF, R _L = 2.0 kΩ. V _{CC} = 5.0 V, C _L = 15 pF, R _L = 2.0 kΩ.
tPHL3 tPHL3	Propagation Delay Data-Output Enable to Output	3.0	26	3.0	39	3.0	39	ns ns	V _{CC} = 5.0 V, C _L = 50 pF, R _L = 2.0 kΩ. V _{CC} = 5.0 V, C _L = 15 pF, R _L = 2.0 kΩ.
tPLH3 tPLH3	Propagation Delay Data-Output Enable to Output	3.0	25	3.0	38	3.0	38	ns ns	V _{CC} = 5.0 V, C _L = 50 pF, R _L = 2.0 kΩ. V _{CC} = 5.0 V, C _L = 15 pF, R _L = 2.0 kΩ.
tPHL5 tPHL5	Propagation Delay Data-Output Select to Output	3.0	32	3.0	48	3.0	48	ns ns	V _{CC} = 5.0 V, C _L = 50 pF, R _L = 2.0 kΩ. V _{CC} = 5.0 V, C _L = 15 pF, R _L = 2.0 kΩ.
tPLH5 tPLH5	Propagation Delay Data-Output Select to Output	3.0	28	3.0	42	3.0	42	ns ns	V _{CC} = 5.0 V, C _L = 50 pF, R _L = 2.0 kΩ. V _{CC} = 5.0 V, C _L = 15 pF, R _L = 2.0 kΩ.

NOTE:

- The limits specified for C_L = 15 pF are guaranteed but not tested.