

# RN1201, 1202, 1203 RN1204, 1205, 1206

(RN1201)

SWITCHING, INVERTER CIRCUIT, INTERFACE CIRCUIT  
AND DRIVER CIRCUIT APPLICATIONS.

- With Built-in Bias Resistors
- Simplify Circuit Design
- Reduce a Quantity of Parts and Manufacturing Process
- Complementary to RN2201~2206

EQUIVALENT CIRCUIT AND BIAS RESISTOR VALUES

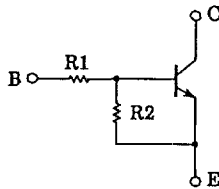

TYPE No.	R1 (k $\Omega$ )	R2 (k $\Omega$ )
RN1201	4.7	4.7
RN1202	10	10
RN1203	22	22
RN1204	47	47
RN1205	2.2	47
RN1206	4.7	47

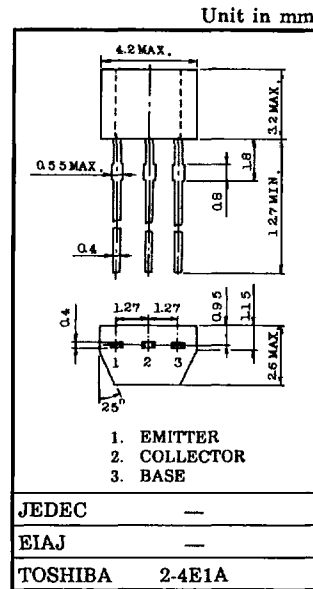

Weight : 0.13g

MAXIMUM RATINGS (Ta = 25°C)

CHARACTERISTIC		SYMBOL	RATING	UNIT
Collector-Base Voltage	RN1201~1206	V <sub>CBO</sub>	50	V
Collector-Emitter Voltage		V <sub>CEO</sub>	50	V
Emitter-Base Voltage	RN1201~1204	V <sub>EBO</sub>	10	V
	RN1205, 1206		5	V
Collector Current	RN1201~1206	I <sub>C</sub>	100	mA
Collector Power Dissipation		P <sub>C</sub>	300	mW
Junction Temperature		T <sub>j</sub>	150	°C
Storage Temperature Range		T <sub>stg</sub>	-55~150	°C

**RN1201, 1202, 1203**  
**RN1204, 1205, 1206**

(RN1201)

**ELECTRICAL CHARACTERISTICS (Ta = 25°C)**

CHARACTERISTIC		SYMBOL	TEST CONDITION	MIN.	TYP.	MAX.	UNIT
Collector Cut-off Current	RN1201~1206	$I_{CBO}$	$V_{CB}=50V, I_E=0$	—	—	100	nA
		$I_{CEO}$	$V_{CE}=50V, I_B=0$	—	—	500	nA
Emitter Cut-off Current	RN1201	$I_{EBO}$	$V_{EB}=10V, I_C=0$	0.82	—	1.52	mA
	RN1202			0.38	—	0.71	
	RN1203			0.17	—	0.33	
	RN1204		0.082	—	0.15		
	RN1205		0.078	—	0.145		
	RN1206		0.074	—	0.138		
DC Current Gain	RN1201	$h_{FE}$	$V_{CE}=5V,$ $I_C=10mA$	30	—	—	
	RN1202			50	—	—	
	RN1203			70	—	—	
	RN1204			80	—	—	
	RN1205			80	—	—	
	RN1206			80	—	—	
Collector-Emitter Saturation Voltage	RN1201~1206	$V_{CE(sat)}$	$I_C=5mA$ $I_B=0.25mA$	—	0.1	0.3	V
Input Voltage (ON)	RN1201	$V_{I(ON)}$	$V_{CE}=0.2V,$ $I_C=5mA$	1.1	—	2.0	V
	RN1202			1.2	—	2.4	
	RN1203			1.3	—	3.0	
	RN1204			1.5	—	5.0	
	RN1205			0.6	—	1.1	
	RN1206			0.7	—	1.3	
Input Voltage (OFF)	RN1201~1204	$V_{I(OFF)}$	$V_{CE}=5V,$ $I_C=0.1mA$	1.0	—	1.5	V
	RN1205~1206			0.5	—	0.8	
Transition Frequency	RN1201~1206	$f_T$	$V_{CE}=10V,$ $I_C=5mA$	—	250	—	MHz
Collector Output Capacitance	RN1201~1206	$C_{ob}$	$V_{CB}=10V, I_E=0$ $f=1MHz$	—	3	6	pF
Input Resistor	RN1201	R1	—	3.29	4.7	6.11	kΩ
	RN1202			7	10	13	
	RN1203			15.4	22	28.6	
	RN1204			32.9	47	61.1	
	RN1205			1.54	2.2	2.86	
	RN1206			3.29	4.7	6.11	
Resistor Ratio	RN1201~1204	R1 / R2	—	0.9	1.0	1.1	
	RN1205			0.0421	0.0468	0.0515	
	RN1206			0.09	0.1	0.11	

# RN1201, 1202, 1203 RN1204, 1205, 1206

(RN1201)

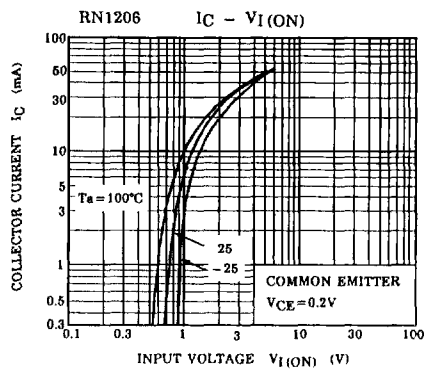
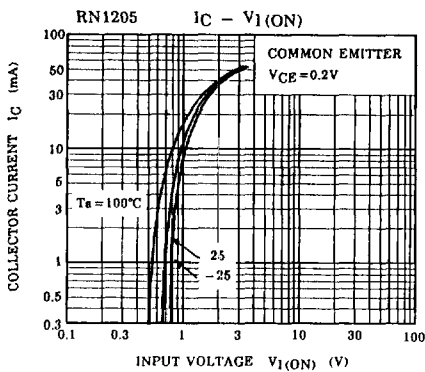
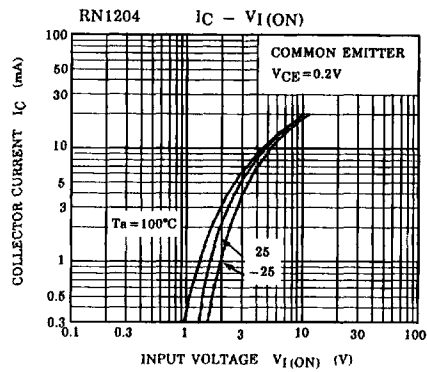
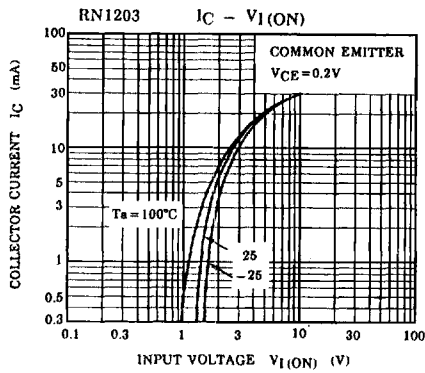
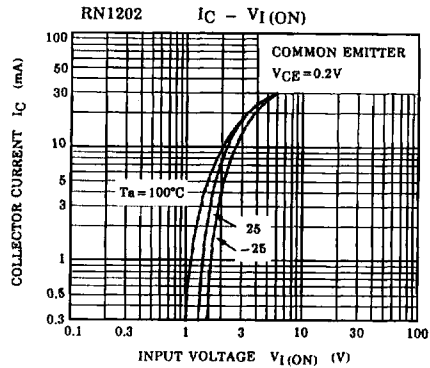
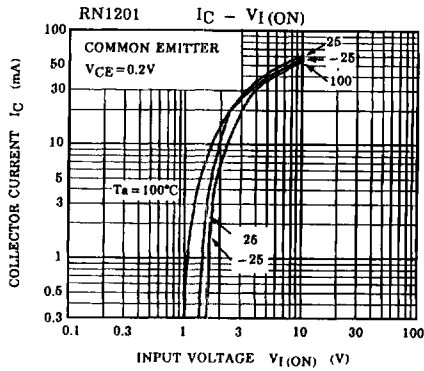

# RN1201, 1202, 1203 RN1204, 1205, 1206

(RN1201)

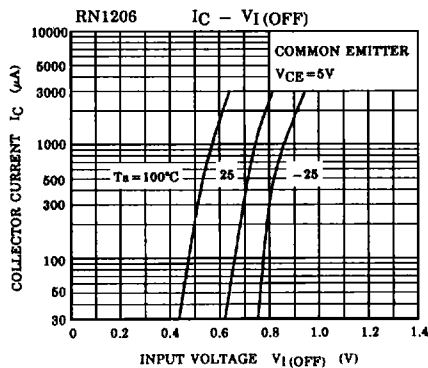
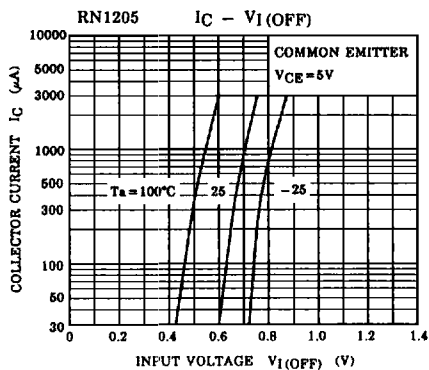
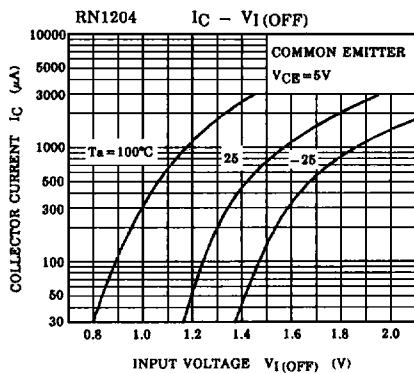
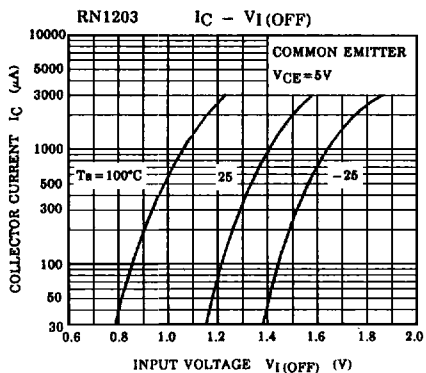
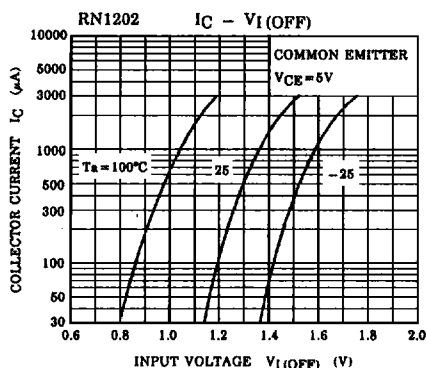
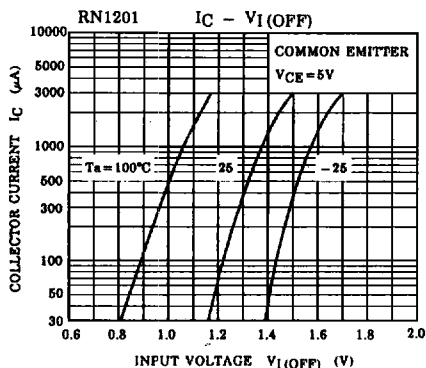

# RN1201, 1202, 1203 RN1204, 1205, 1206

(RN1201)

