

# DSP56302A

## Advance Information 24-BIT GENERAL PURPOSE DIGITAL SIGNAL PROCESSOR

The DSP56302A is a member of the DSP56300 core family of programmable CMOS Digital Signal Processors (DSPs). This family uses a high performance, single-clock-cycle-per-instruction engine providing a two-fold performance increase over Motorola's popular DSP56000 core, while retaining code compatibility. Significant architectural enhancements in the DSP56300 family include a barrel shifter, 24-bit addressing, instruction cache, and Direct Memory Access (DMA). The DSP56302A offers 66/80/100 MIPS at 3.0–3.6 V using an internal 66/80/100 MHz clock. The large on-chip memories can support wireless infrastructure and local loop applications and allow the chip to be used for RAM-based emulation of low-cost ROM-based solutions. The DSP56300 core family offers a new level of performance in speed and power provided by its rich instruction set and low power dissipation, enabling a new generation of wireless, telecommunications, and multimedia products.

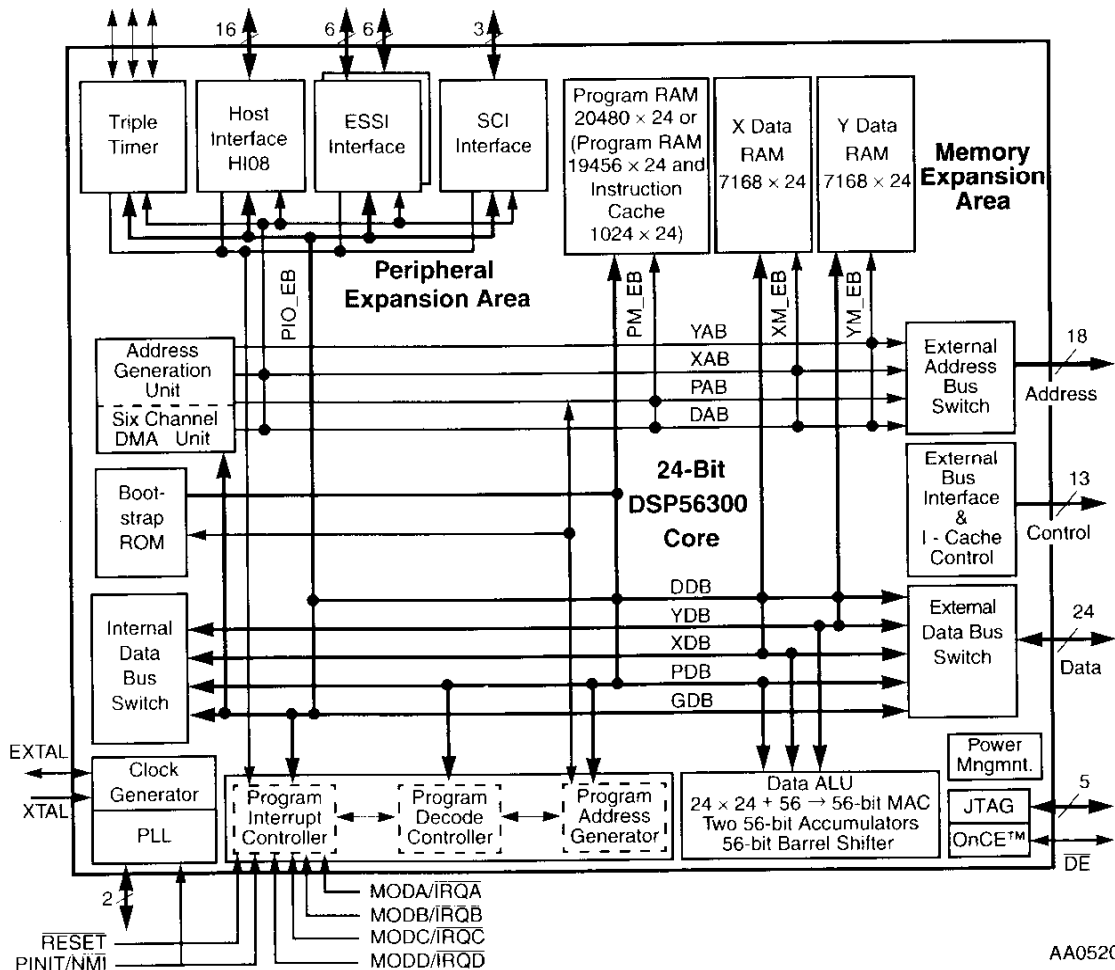

Figure 1 DSP56302A Block Diagram

This document contains information on a new product. Specifications and information herein are subject to change without notice.

### Preliminary Information

## TABLE OF CONTENTS

SECTION 1	SIGNAL/CONNECTION DESCRIPTIONS .....	1-1
SECTION 2	SPECIFICATIONS .....	2-1
SECTION 3	PACKAGING .....	3-1
SECTION 4	DESIGN CONSIDERATIONS .....	4-1
SECTION 5	ORDERING INFORMATION .....	5-1
APPENDIX A	POWER CONSUMPTION BENCHMARK .....	A-1
APPENDIX B	BOOTSTRAP PROGRAMS .....	B-1
	INDEX .....	Index-1

### FOR TECHNICAL ASSISTANCE:

**Telephone:** 1-800-521-6274

**Email:** [dsphelp@dsp.sps.mot.com](mailto:dsphelp@dsp.sps.mot.com)

**Internet:** <http://www.motorola-dsp.com>

## Data Sheet Conventions

This data sheet uses the following conventions:

- $\overline{\text{OVERBAR}}$  Used to indicate a signal that is active when pulled low (For example, the  $\overline{\text{RESET}}$  pin is active when low.)
- “asserted” Means that a high true (active high) signal is high or that a low true (active low) signal is low
- “deasserted” Means that a high true (active high) signal is low or that a low true (active low) signal is high

Examples:	Signal/Symbol	Logic State	Signal State	Voltage <sup>1</sup>
	$\overline{\text{PIN}}$	True	Asserted	$V_{\text{IL}}/V_{\text{OL}}$
	$\overline{\text{PIN}}$	False	Deasserted	$V_{\text{IH}}/V_{\text{OH}}$
	PIN	True	Asserted	$V_{\text{IH}}/V_{\text{OH}}$
	PIN	False	Deasserted	$V_{\text{IL}}/V_{\text{OL}}$

Note: Values for  $V_{\text{IL}}$ ,  $V_{\text{OL}}$ ,  $V_{\text{IH}}$ , and  $V_{\text{OH}}$  are defined by individual product specifications.

### Preliminary Information

## FEATURES

### High Performance DSP56300 Core

- 66/80/100 Million Instructions Per Second (MIPS) with a 66/80/100 MHz clock at 3.0–3.6 V
- Object code compatible with the DSP56000 core
- Highly parallel instruction set
- Data Arithmetic Logic Unit (Data ALU)
  - Fully pipelined 24 x 24-bit parallel Multiplier-Accumulator (MAC)
  - 56-bit parallel barrel shifter (fast shift and normalization; bit stream generation and parsing)
  - Conditional ALU instructions
  - 24-bit or 16-bit arithmetic support under software control
- Program Control Unit (PCU)
  - Position Independent Code (PIC) support
  - Addressing modes optimized for DSP applications (including immediate offsets)
  - On-chip instruction cache controller
  - On-chip memory-expandable hardware stack
  - Nested hardware DO loops
  - Fast auto-return interrupts
- Direct Memory Access (DMA)
  - Six DMA channels supporting internal and external accesses
  - One-, two-, and three-dimensional transfers (including circular buffering)
  - End-of-block-transfer interrupts
  - Triggering from interrupt lines and all peripherals
- Phase Lock Loop (PLL)
  - Allows change of low power Divide Factor (DF) without loss of lock
  - Output clock with skew elimination

### Preliminary Information

**Features**

- Hardware debugging support
  - On-Chip Emulation (OnCE™) module
  - Joint Action Test Group (JTAG) Test Access Port (TAP)
  - Address Trace mode reflects internal Program RAM accesses at the external port

**On-Chip Memories**

- Program RAM, Instruction Cache, X data RAM, and Y data RAM size is programmable.

Instruction Cache	Switch Mode	Program RAM Size	Instruction Cache Size	X Data RAM Size	Y Data RAM Size
disabled	disabled	20480 × 24-bit	0	7168 × 24-bit	7168 × 24-bit
enabled	disabled	19456 × 24-bit	1024 × 24-bit	7168 × 24-bit	7168 × 24-bit
disabled	enabled	24576 × 24-bit	0	5120 × 24-bit	5120 × 24-bit
enabled	enabled	23552 × 24-bit	1024 × 24-bit	5120 × 24-bit	5120 × 24-bit

- 192 × 24-bit bootstrap ROM

**Off-Chip Memory Expansion**

- Data memory expansion to two 256 K × 24-bit word memory spaces (or up to two 4 M × 24-bit word memory spaces by using the Address Attribute AA0–AA3 signals)
- Program memory expansion to one 256 K × 24-bit words memory space (or up to one 4 M × 24-bit word memory space by using the Address Attribute AA0–AA3 signals)
- External memory expansion port
- Chip Select Logic for glueless interface to SRAMs
- On-chip DRAM Controller for glueless interface to DRAMs

**Preliminary Information**

## On-Chip Peripherals

- Enhanced DSP56000-like 8-bit parallel Host Interface (HI08) supports a variety of buses (e.g., ISA) and provides glueless connection to a number of industry standard microcomputers, microprocessors, and DSPs
- Two Enhanced Synchronous Serial Interfaces (ESSI0 and ESSI1), each with one receiver and three transmitters (allows six-channel home theater)
- Serial Communications Interface (SCI) with baud rate generator
- Triple timer module
- Up to thirty-four programmable General Purpose Input/Output (GPIO) pins, depending on which peripherals are enabled

## Reduced Power Dissipation

- Very low power CMOS design
- Wait and Stop low power standby modes
- Fully-static logic, operation frequency down to 0 Hz (dc)
- Optimized power management circuitry (instruction-dependent, peripheral-dependent, and mode-dependent)

## TARGET APPLICATIONS

The DSP56302A is intended for applications requiring a large amount of on-chip memory, such as wireless infrastructure applications. It is also intended as a RAM-based emulation part for low-cost ROM-based solutions

Preliminary Information

**PRODUCT DOCUMENTATION**

The three documents listed in the following table are required for a complete description of the DSP56302A and are necessary to design properly with the part. Documentation is available from one of the following locations (see back cover for detailed information):

- A local Motorola distributor
- A Motorola semiconductor sales office
- A Motorola Literature Distribution Center
- The World Wide Web (WWW)

See the **Additional Support** section of the *DSP56300 Family Manual* for detailed information on the multiple support options available to you.

**Table 1** DSP56303 Documentation

Name	Description	Order Number
DSP56300 Family Manual	Detailed description of the DSP56300 family processor core and instruction set	DSP56300FM/AD
DSP56302 User's Manual	Detailed functional description of the DSP56302 memory configuration, operation, and register programming	DSP56302UM/AD
DSP56302A Technical Data	DSP56302A features list and physical, electrical, timing, and package specifications	DSP56302A/D



# SECTION 1

## SIGNAL/CONNECTION DESCRIPTIONS

---

### SIGNAL GROUPINGS

The input and output signals of the DSP56302A are organized into functional groups, as shown in **Table 1-1** and as illustrated in **Figure 1-1**.

**Table 1-1** DSP56302A Functional Signal Groupings

Functional Group		Number of Signals	Detailed Description
Power ( $V_{CC}$ )		20	<b>Table 1-2</b>
Ground (GND)		19	<b>Table 1-3</b>
Clock		2	<b>Table 1-4</b>
PLL		3	<b>Table 1-5</b>
Address Bus	Port A <sup>1</sup>	18	<b>Table 1-6</b>
Data Bus		24	<b>Table 1-7</b>
Bus Control		13	<b>Table 1-8</b>
Interrupt and Mode Control		5	<b>Table 1-9</b>
Host Interface (HI08)	Port B <sup>2</sup>	16	<b>Table 1-11</b>
Enhanced Synchronous Serial Interface (ESSI)	Ports C and D <sup>3</sup>	12	<b>Table 1-12 and Table 1-13</b>
Serial Communication Interface (SCI)	Port E <sup>4</sup>	3	<b>Table 1-14</b>
Timer		3	<b>Table 1-15</b>
OnCE/JTAG Port		6	<b>Table 1-16</b>
Notes: 1. Port A signals define the external memory interface port, including the external address bus, data bus, and control signals. 2. Port B signals are the HI08 port signals multiplexed with the GPIO signals. 3. Port C and D signals are the two ESSI port signals multiplexed with the GPIO signals. 4. Port E signals are the SCI port signals multiplexed with the GPIO signals.			

**Figure 1-1** is a diagram of DSP56302A signals by functional group.

### Preliminary Information

# Signal/Connection Descriptions

## Signal Groupings

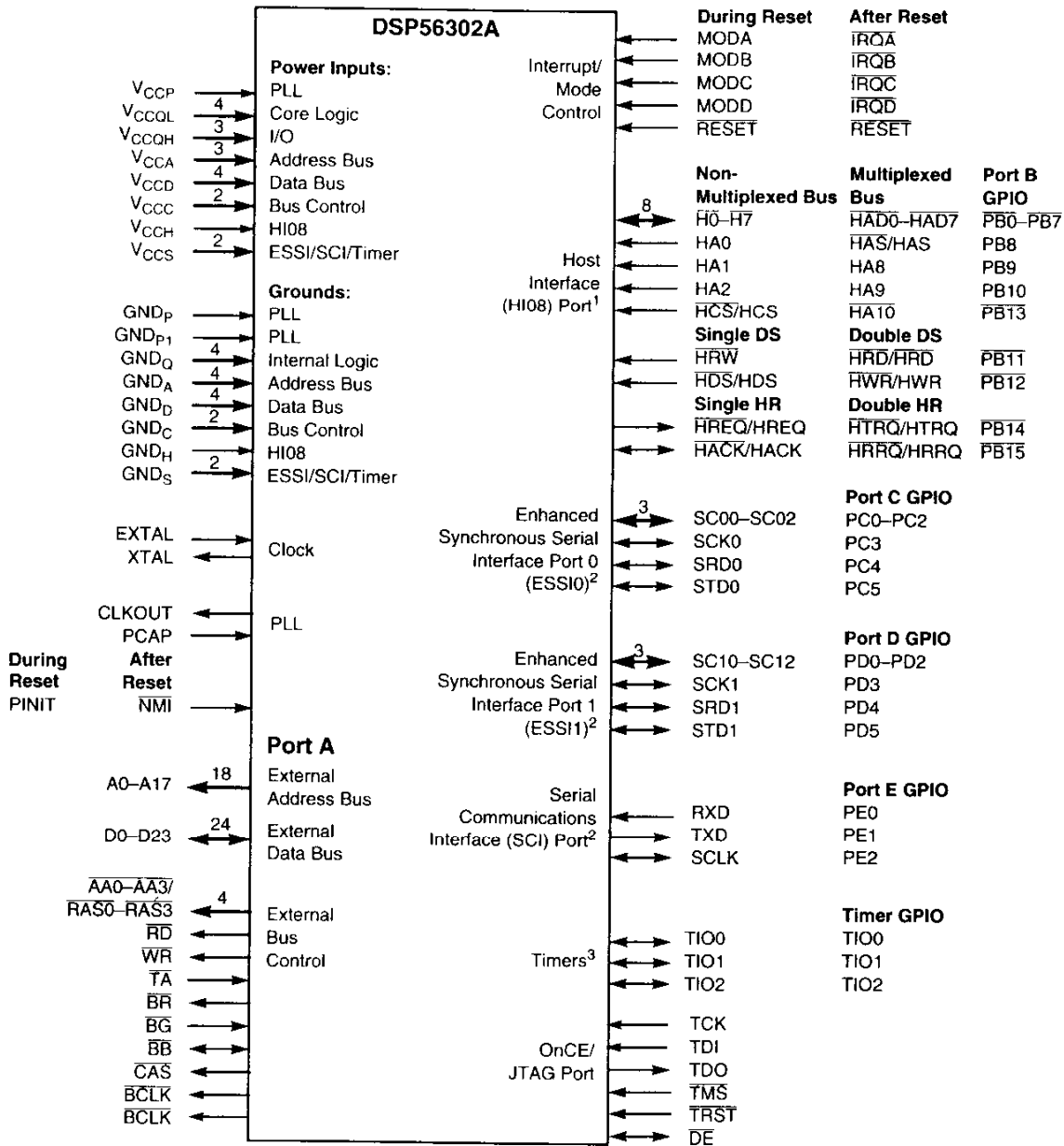

- Notes:
1. The HI08 port supports a non-multiplexed or a multiplexed bus, single or double Data Strobe (DS), and single or double Host Request (HR) configurations. Since each of these modes is configured independently, any combination of these modes is possible. These HI08 signals can also be configured alternately as GPIO signals (PB0-PB15). Signals with dual designations (e.g., HAS/HAS) have configurable polarity.
  2. The ESSI0, ESSI1, and SCI signals are multiplexed with the Port C GPIO signals (PC0-PC5), Port D GPIO signals (PD0-PD5), and Port E GPIO signals (PE0-PE2), respectively.
  3. TIO0-TIO2 can be configured as GPIO signals.
- AA0601

Figure 1-1 Signals Identified by Functional Group

## Preliminary Information



**POWER****Table 1-2 Power Inputs**

Power Name	Description
$V_{CCP}$	<b>PLL Power</b> — $V_{CCP}$ is $V_{CC}$ dedicated for Phase Lock Loop (PLL) use. The voltage should be well-regulated and the input should be provided with an extremely low impedance path to the $V_{CC}$ power rail. There is one $V_{CCP}$ input.
$V_{CCQL}$ (3)	<b>Quiet Core (Low) Power</b> — $V_{CCQL}$ is an isolated power for the core processing logic. This input must be isolated externally from all other chip power inputs. The user must provide adequate external decoupling capacitors. There are three $V_{CCQL}$ inputs.
$V_{CCQH}$ (4)	<b>Quiet External (High) Power</b> — $V_{CCQH}$ is a quiet power source for I/O lines. This input must be tied externally to all other chip power inputs, <i>except</i> $V_{CCQL}$ . The user must provide adequate decoupling capacitors. There are four $V_{CCQH}$ inputs.
$V_{CCA}$ (3)	<b>Address Bus Power</b> — $V_{CCA}$ is an isolated power for sections of the address bus I/O drivers. This input must be tied externally to all other chip power inputs, <i>except</i> $V_{CCQL}$ . The user must provide adequate external decoupling capacitors. There are four $V_{CCA}$ inputs.
$V_{CCD}$ (4)	<b>Data Bus Power</b> — $V_{CCD}$ is an isolated power for sections of the data bus I/O drivers. This input must be tied externally to all other chip power inputs. The user must provide adequate external decoupling capacitors. There are four $V_{CCD}$ inputs.
$V_{CCC}$ (2)	<b>Bus Control Power</b> — $V_{CCC}$ is an isolated power for the bus control I/O drivers. This input must be tied externally to all other chip power inputs, <i>except</i> $V_{CCQL}$ . The user must provide adequate external decoupling capacitors. There are two $V_{CCC}$ inputs.
$V_{CCH}$	<b>Host Power</b> — $V_{CCH}$ is an isolated power for the HI08 I/O drivers. This input must be tied externally to all other chip power inputs, <i>except</i> $V_{CCQL}$ . The user must provide adequate external decoupling capacitors. There is one $V_{CCH}$ input.
$V_{CCS}$ (2)	<b>ESSI, SCI, and Timer Power</b> — $V_{CCS}$ is an isolated power for the ESSI, SCI, and timer I/O drivers. This input must be tied externally to all other chip power inputs, <i>except</i> $V_{CCQL}$ . The user must provide adequate external decoupling capacitors. There are two $V_{CCS}$ inputs.
Note:	These designations are package-dependent. Some packages connect all $V_{CC}$ inputs except $V_{CCP}$ to each other internally. On those packages, all power input, except $V_{CCP}$ , are labeled $V_{CC}$ . The numbers of connections indicated in this table are minimum values; the total $V_{CC}$ connections are package-dependent.

**Preliminary Information**

## Ground

## GROUND

Table 1-3 Grounds

Ground Name	Description
GND <sub>P</sub>	<b>PLL Ground</b> —GND <sub>P</sub> is ground dedicated for PLL use. The connection should be provided with an extremely low-impedance path to ground. V <sub>CCP</sub> should be bypassed to GND <sub>P</sub> by a 0.47 μF capacitor located as close as possible to the chip package. There is one GND <sub>P</sub> connection.
GND <sub>P1</sub>	<b>PLL Ground 1</b> —GND <sub>P1</sub> is ground dedicated for PLL use. The connection should be provided with an extremely low-impedance path to ground. There is one GND <sub>P1</sub> connection.
GND <sub>Q</sub> (4)	<b>Quiet Ground</b> —GND <sub>Q</sub> is an isolated ground for the internal processing logic. This connection must be tied externally to all other chip ground connections. The user must provide adequate external decoupling capacitors. There are four GND <sub>Q</sub> connections.
GND <sub>A</sub> (4)	<b>Address Bus Ground</b> —GND <sub>A</sub> is an isolated ground for sections of the address bus I/O drivers. This connection must be tied externally to all other chip ground connections. The user must provide adequate external decoupling capacitors. There are four GND <sub>A</sub> connections.
GND <sub>D</sub> (4)	<b>Data Bus Ground</b> —GND <sub>D</sub> is an isolated ground for sections of the data bus I/O drivers. This connection must be tied externally to all other chip ground connections. The user must provide adequate external decoupling capacitors. There are four GND <sub>D</sub> connections.
GND <sub>C</sub> (2)	<b>Bus Control Ground</b> —GND <sub>C</sub> is an isolated ground for the bus control I/O drivers. This connection must be tied externally to all other chip ground connections. The user must provide adequate external decoupling capacitors. There are two GND <sub>C</sub> connections.
GND <sub>H</sub>	<b>Host Ground</b> —GND <sub>H</sub> is an isolated ground for the HI08 I/O drivers. This connection must be tied externally to all other chip ground connections. The user must provide adequate external decoupling capacitors. There is one GND <sub>H</sub> connection.
GND <sub>S</sub> (2)	<b>ESSI, SCI, and Timer Ground</b> —GND <sub>S</sub> is an isolated ground for the ESSI, SCI, and timer I/O drivers. This connection must be tied externally to all other chip ground connections. The user must provide adequate external decoupling capacitors. There are two GND <sub>S</sub> connections.
Note:	These designations are package-dependent. Some packages connect all GND inputs, except GND <sub>P</sub> and GND <sub>P1</sub> , to each other internally. On those packages, all ground connections, except GND <sub>P</sub> and GND <sub>P1</sub> , are labeled GND. The numbers of connections indicated in this table are minimum values; the total GND connections are package-dependent.

## Preliminary Information

**CLOCK****Table 1-4** Clock Signals

Signal Name	Type	State During Reset	Signal Description
EXTAL	Input	Input	<b>External Clock/Crystal Input</b> —EXTAL interfaces the internal crystal oscillator input to an external crystal or an external clock.
XTAL	Output	Chip Driven	<b>Crystal Output</b> —XTAL connects the internal crystal oscillator output to an external crystal. If an external clock is used, leave XTAL unconnected.

**PHASE LOCK LOOP (PLL)****Table 1-5** Phase Lock Loop Signals

Signal Name	Type	State During Reset	Signal Description
PCAP	Input	Input	<b>PLL Capacitor</b> —PCAP is an input connecting an off-chip capacitor to the PLL filter. Connect one capacitor terminal to PCAP and the other terminal to $V_{CC}$ .  If the PLL is not used, PCAP may be tied to $V_{CC}$ , GND, or left floating.
CLKOUT	Output	Chip Driven	<b>Clock Output</b> —CLKOUT provides an output clock synchronized to the internal core clock phase.  If the PLL is enabled and both the Multiplication and Division Factors equal one, then CLKOUT is also synchronized to EXTAL.  If the PLL is disabled, the CLKOUT frequency is half the frequency of EXTAL.
PINIT	Input	Input	<b>PLL Initial</b> —During assertion of $\overline{\text{RESET}}$ , the value of PINIT is written into the PLL Enable (PEN) bit of the PLL Control (PCTL) register, determining whether the PLL is enabled or disabled.
$\overline{\text{NMI}}$	Input		<b>Non-Maskable Interrupt</b> —After $\overline{\text{RESET}}$ deassertion and during normal instruction processing, this Schmitt-trigger input is the negative-edge-triggered Non-Maskable Interrupt (NMI) request internally synchronized to CLKOUT.

**Preliminary Information**

**EXTERNAL MEMORY EXPANSION PORT (PORT A)**

**Note:** When the DSP56302A enters a low-power standby mode (Stop or Wait), it releases bus mastership and tri-states the relevant Port A signals: A0–A17, D0–D23, AA0/ $\overline{\text{RAS0}}$ –AA3/ $\overline{\text{RAS3}}$ , RD, WR, BB, CAS, BCLK,  $\overline{\text{BCLK}}$ .

**EXTERNAL ADDRESS BUS**

Table 1-6 External Address Bus Signals

Signal Name	Type	State During Reset	Signal Description
A0–A17	Output	Tri-stated	<b>Address Bus</b> —When the DSP is the bus master, A0–A17 are active-high outputs that specify the address for external program and data memory accesses. Otherwise, the signals are tri-stated. To minimize power dissipation, A0–A17 do not change state when external memory spaces are not being accessed.

**EXTERNAL DATA BUS**

Table 1-7 External Data Bus Signals

Signal Name	Type	State During Reset	Signal Description
D0–D23	Input/Output	Tri-stated	<b>Data Bus</b> —When the DSP is the bus master, D0–D23 are active-high, bidirectional input/outputs that provide the bidirectional data bus for external program and data memory accesses. Otherwise, D0–D23 are tri-stated.

**EXTERNAL BUS CONTROL**

Table 1-8 External Bus Control Signals

Signal Name	Type	State During Reset	Signal Description
AA0–AA3	Output	Tri-stated	<b>Address Attribute</b> —When defined as AA, these signals can be used as chip selects or additional address lines.
$\overline{\text{RAS0}}$ – $\overline{\text{RAS3}}$	Output		<b>Row Address Strobe</b> —When defined as $\overline{\text{RAS}}$ , these signals can be used as $\overline{\text{RAS}}$ for Dynamic Random Access Memory (DRAM) interface. These signals are tri-statable outputs with programmable polarity.
$\overline{\text{RD}}$	Output	Tri-stated	<b>Read Enable</b> —When the DSP is the bus master, $\overline{\text{RD}}$ is an active-low output that is asserted to read external memory on the data bus (D0–D23). Otherwise, $\overline{\text{RD}}$ is tri-stated.

**Preliminary Information**

Table 1-8 External Bus Control Signals (Continued)

Signal Name	Type	State During Reset	Signal Description
$\overline{WR}$	Output	Tri-stated	<b>Write Enable</b> —When the DSP is the bus master, $\overline{WR}$ is an active-low output that is asserted to write external memory on the data bus (D0–D23). Otherwise, the signals are tri-stated.
$\overline{TA}$	Input	Ignored Input	<p><b>Transfer Acknowledge</b>—If the DSP56302A is the bus master and there is no external bus activity, or the DSP56302A is not the bus master, the <math>\overline{TA}</math> input is ignored. The <math>\overline{TA}</math> input is a Data Transfer Acknowledge (DTACK) function that can extend an external bus cycle indefinitely. Any number of wait states (1, 2, ..., infinity) may be added to the wait states inserted by the BCR by keeping <math>\overline{TA}</math> deasserted. In typical operation, <math>\overline{TA}</math> is deasserted at the start of a bus cycle, is asserted to enable completion of the bus cycle, and is deasserted before the next bus cycle. The current bus cycle completes one clock period after <math>\overline{TA}</math> is asserted synchronous to CLKOUT. The number of wait states is determined by the <math>\overline{TA}</math> input or by the Bus Control Register (BCR), whichever is longer. The BCR can be used to set the minimum number of wait states in external bus cycles.</p> <p>In order to use the <math>\overline{TA}</math> functionality, the BCR must be programmed to at least one wait state. A zero wait state access can not be extended by <math>\overline{TA}</math> deassertion, otherwise improper operation may result. <math>\overline{TA}</math> can operate synchronously or asynchronously depending on the setting of the TAS bit in the Operating Mode Register (OMR).</p> <p><math>\overline{TA}</math> functionality may not be used while performing DRAM type accesses, otherwise improper operation may result.</p>
$\overline{BR}$	Output	Output (deasserted)	<b>Bus Request</b> — $\overline{BR}$ is an active-low output, never tri-stated. $\overline{BR}$ is asserted when the DSP requests bus mastership. $\overline{BR}$ is deasserted when the DSP no longer needs the bus. $\overline{BR}$ may be asserted or deasserted independent of whether the DSP56302A is a bus master or a bus slave. Bus “parking” allows $\overline{BR}$ to be deasserted even though the DSP56302A is the bus master (see the description of bus “parking” in the $\overline{BB}$ signal description). The Bus Request Hole (BRH) bit in the BCR allows $\overline{BR}$ to be asserted under software control even though the DSP does not need the bus. $\overline{BR}$ is typically sent to an external bus arbitrator that controls the priority, parking and tenure of each master on the same external bus. $\overline{BR}$ is only affected by DSP requests for the external bus, never for the internal bus. During hardware reset, $\overline{BR}$ is deasserted and the arbitration is reset to the Bus Slave state.

## Preliminary Information

Table 1-8 External Bus Control Signals (Continued)

Signal Name	Type	State During Reset	Signal Description
$\overline{BG}$	Input	Ignored Input	<b>Bus Grant</b> — $\overline{BG}$ is an active-low input. $\overline{BG}$ must be asserted/deasserted synchronous to CLKOUT for proper operation. $\overline{BG}$ is asserted by an external bus arbitration circuit when the DSP56302A becomes the next bus master. When $\overline{BG}$ is asserted, the DSP56302A must wait until $\overline{BB}$ is deasserted before taking bus mastership. When $\overline{BG}$ is deasserted, bus mastership is typically given up at the end of the current bus cycle. This may occur in the middle of an instruction that requires more than one external bus cycle for execution.
$\overline{BB}$	Input/Output	Input	<b>Bus Busy</b> — $\overline{BB}$ is a bidirectional active-low input/output and must be asserted and deasserted synchronous to CLKOUT. $\overline{BB}$ indicates that the bus is active. Only after $\overline{BB}$ is deasserted can the pending bus master become the bus master (and then assert the signal again). The bus master may keep $\overline{BB}$ asserted after ceasing bus activity regardless of whether $\overline{BR}$ is asserted or deasserted. This is called "bus parking" and allows the current bus master to reuse the bus without re-arbitration until another device requires the bus. The deassertion of $\overline{BB}$ is done by an "active pull-up" method (i.e., $\overline{BB}$ is driven high and then released and held high by an external pull-up resistor).  $\overline{BB}$ requires an external pull-up resistor.
$\overline{CAS}$	Output	Tri-stated	<b>Column Address Strobe</b> —When the DSP is the bus master, $\overline{CAS}$ is an active-low output used by DRAM to strobe the column address. Otherwise, if the Bus Mastership Enable (BME) bit in the DRAM Control Register is cleared, the signal is tri-stated.
BCLK	Output	Tri-stated	<b>Bus Clock</b> —When the DSP is the bus master, BCLK is an active-high output. BCLK is active as a sampling signal when the program Address Tracing mode is enabled (by setting the ATE bit in the OMR). When BCLK is active and synchronized to CLKOUT by the internal PLL, BCLK precedes CLKOUT by one-fourth of a clock cycle. The BCLK rising edge may be used to sample the internal Program Memory access on the A0–A23 address lines.
$\overline{BCLK}$	Output	Tri-stated	<b>Bus Clock Not</b> —When the DSP is the bus master, $\overline{BCLK}$ is an active-low output and is the inverse of the BCLK signal. Otherwise, the signal is tri-stated.

## Preliminary Information

## INTERRUPT AND MODE CONTROL

The interrupt and mode control signals select the chip's operating mode as it comes out of hardware reset. After  $\overline{\text{RESET}}$  is deasserted, these inputs are hardware interrupt request lines.

Table 1-9 Interrupt and Mode Control

Signal Name	Type	State During Reset	Signal Description
$\overline{\text{RESET}}$	Input	Input	<b>Reset</b> — $\overline{\text{RESET}}$ is an active-low, Schmitt-trigger input. Deassertion of $\overline{\text{RESET}}$ is internally synchronized to the clock out (CLKOUT). When asserted, the chip is placed in the Reset state and the internal phase generator is reset. The Schmitt-trigger input allows a slowly rising input (such as a capacitor charging) to reset the chip reliably. If $\overline{\text{RESET}}$ is deasserted synchronous to CLKOUT, exact start-up timing is guaranteed, allowing multiple processors to start synchronously and operate together in "lock-step." When the $\overline{\text{RESET}}$ signal is deasserted, the initial chip operating mode is latched from the MODA, MODB, MODC, and MODD inputs. The $\overline{\text{RESET}}$ signal must be asserted after power up.
MODA	Input	Input	<b>Mode Select A</b> —MODA is an active-low Schmitt-trigger input, internally synchronized to CLKOUT. MODA, MODB, MODC, and MODD select one of sixteen initial chip operating modes, latched into the OMR when the $\overline{\text{RESET}}$ signal is deasserted.
$\overline{\text{IRQA}}$	Input		<b>External Interrupt Request A</b> —After reset, this input becomes a level-sensitive or negative-edge-triggered, maskable interrupt request input during normal instruction processing. If $\overline{\text{IRQA}}$ is asserted synchronous to CLKOUT, multiple processors can be re-synchronized using the WAIT instruction and asserting $\overline{\text{IRQA}}$ to exit the Wait state. If the processor is in the Stop standby state and $\overline{\text{IRQA}}$ is asserted, the processor will exit the Stop state.

### Preliminary Information

## Interrupt and Mode Control

Table 1-9 Interrupt and Mode Control (Continued)

Signal Name	Type	State During Reset	Signal Description
MODB	Input	Input	<b>Mode Select B</b> —MODB is an active-low Schmitt-trigger input, internally synchronized to CLKOUT. MODA, MODB, MODC, and MODD select one of sixteen initial chip operating modes, latched into the OMR when the $\overline{\text{RESET}}$ signal is deasserted.
$\overline{\text{IRQB}}$	Input		<b>External Interrupt Request B</b> —After reset, this input becomes a level-sensitive or negative-edge-triggered, maskable interrupt request input during normal instruction processing. If $\overline{\text{IRQB}}$ is asserted synchronous to CLKOUT, multiple processors can be re-synchronized using the WAIT instruction and asserting $\overline{\text{IRQB}}$ to exit the Wait state. If the processor is in the Stop standby state and $\overline{\text{IRQB}}$ is asserted, the processor will exit the Stop state.
MODC	Input	Input	<b>Mode Select C</b> —MODC is an active-low Schmitt-trigger input, internally synchronized to CLKOUT. MODA, MODB, MODC, and MODD select one of sixteen initial chip operating modes, latched into the OMR when the $\overline{\text{RESET}}$ signal is deasserted.
$\overline{\text{IRQC}}$	Input		<b>External Interrupt Request C</b> —After reset, this input becomes a level-sensitive or negative-edge-triggered, maskable interrupt request input during normal instruction processing. If $\overline{\text{IRQC}}$ is asserted synchronous to CLKOUT, multiple processors can be re-synchronized using the WAIT instruction and asserting $\overline{\text{IRQC}}$ to exit the Wait state. If the processor is in the Stop standby state and $\overline{\text{IRQC}}$ is asserted, the processor will exit the Stop state.
MODD	Input	Input	<b>Mode Select D</b> —MODD is an active-low Schmitt-trigger input, internally synchronized to CLKOUT. MODA, MODB, MODC, and MODD select one of sixteen initial chip operating modes, latched into the OMR when the $\overline{\text{RESET}}$ signal is deasserted.
$\overline{\text{IRQD}}$	Input		<b>External Interrupt Request D</b> —After reset, this input becomes a level-sensitive or negative-edge-triggered, maskable interrupt request input during normal instruction processing. If $\overline{\text{IRQD}}$ is asserted synchronous to CLKOUT, multiple processors can be re-synchronized using the WAIT instruction and asserting $\overline{\text{IRQD}}$ to exit the Wait state. If the processor is in the Stop standby state and $\overline{\text{IRQD}}$ is asserted, the processor will exit the Stop state.

## Preliminary Information



## HOST INTERFACE (HI08)

The HI08 provides a fast parallel data to 8-bit port, which may be connected directly to the host bus.

The HI08 supports a variety of standard buses, and can be directly connected to a number of industry standard microcomputers, microprocessors, DSPs, and DMA hardware.

### Host Port Usage Considerations

Careful synchronization is required when reading multiple-bit registers that are written by another asynchronous system. This is a common problem when two asynchronous systems are connected (as they are in the Host port). The considerations for proper operation are discussed in the following table:

**Table 1-10** Host Port Usage Considerations

Action	Description
Asynchronous read of receive byte registers	When reading the receive byte registers, Receive register High (RXH), Receive register Middle (RXM), or Receive register Low (RXL), the host interface programmer should use interrupts or poll the Receive register Data Full (RXDF) flag which indicates that data is available. This assures that the data in the receive byte registers will be valid.
Asynchronous write to transmit byte registers	The host interface programmer should not write to the transmit byte registers, Transmit register High (TXH), Transmit register Middle (TXM), or Transmit register Low (TXL), unless the Transmit register Data Empty (TXDE) bit is set indicating that the transmit byte registers are empty. This guarantees that the transmit byte registers will transfer valid data to the Host Receive (HRX) register.
Asynchronous write to host vector	The host interface programmer should change the Host Vector (HV) register only when the Host Command bit (HC) is clear. This will guarantee that the DSP interrupt control logic will receive a stable vector.

### Preliminary Information

## Host Port Configuration

The functions of the signals associated with the HI08 vary according to the programmed configuration of the interface as determined by the 16 bits in the HI08 Port Control Register (HPCR). Refer to the *DSP56302A User's Manual* for detailed descriptions of this and the other configuration registers used with the HI08.

Table 1-11 Host Interface

Signal Name	Type	State During Reset	Signal Description
H0–H7	Input/Output	Tri-stated	<b>Host Data</b> —When the HI08 is programmed to interface a non-multiplexed host bus and the HI function is selected, these signals are lines 0–7 of the Data bidirectional, tri-state bus.
HAD0–HAD7	Input/Output		<b>Host Address</b> —When HI08 is programmed to interface a multiplexed host bus and the HI function is selected, these signals are lines 0–7 of the Address/Data bidirectional, multiplexed, tri-state bus.
PB0–PB7	Input or Output		<b>Port B 0–7</b> —When the HI08 is configured as GPIO through the HPCR, these signals are individually programmed as inputs or outputs through the HI08 Data Direction Register (HDDR).
HA0	Input	Input	<b>Host Address Input 0</b> —When the HI08 is programmed to interface a non-multiplexed host bus and the HI function is selected, this signal is line 0 of the Host Address input bus.
$\overline{\text{HAS}}$ /HAS	Input		<b>Host Address Strobe</b> —When HI08 is programmed to interface a multiplexed host bus and the HI function is selected, this signal is the Host Address Strobe (HAS) Schmitt-trigger input. The polarity of the address strobe is programmable but is configured active-low (HAS) following reset.
PB8	Input or Output		<b>Port B 8</b> —When the HI08 is configured as GPIO through the HPCR, this signal is individually programmed as an input or output through the HDDR.

Table 1-11 Host Interface (Continued)

Signal Name	Type	State During Reset	Signal Description
HA1	Input	Input	<b>Host Address Input 1</b> —When the HI08 is programmed to interface a non-multiplexed host bus and the HI function is selected, this signal is line 1 of the Host Address (HA1) input bus.
HA8	Input		<b>Host Address 8</b> —When HI08 is programmed to interface a multiplexed host bus and the HI function is selected, this signal is line 8 of the Host Address (HA8) input bus.
PB9	Input or Output		<b>Port B 9</b> —When the HI08 is configured as GPIO through the HPCR, this signal is individually programmed as an input or output through the HDDR.
HA2	Input	Input	<b>Host Address Input 2</b> —When the HI08 is programmed to interface a non-multiplexed host bus and the HI function is selected, this signal is line 2 of the Host Address (HA2) input bus.
HA9	Input		<b>Host Address 9</b> —When HI08 is programmed to interface a multiplexed host bus and the HI function is selected, this signal is line 9 of the Host Address (HA9) input bus.
PB10	Input or Output		<b>Port B 10</b> —When the HI08 is configured as GPIO through the HPCR, this signal is individually programmed as an input or output through the HDDR.
HRW	Input	Input	<b>Host Read/Write</b> —When HI08 is programmed to interface a single-data-strobe host bus and the HI function is selected, this signal is the Host Read/Write (HRW) input.
$\overline{\text{HRD}}$ /HRD	Input		<b>Host Read Data</b> —When HI08 is programmed to interface a double-data-strobe host bus and the HI function is selected, this signal is the Host Read Data strobe (HRD) Schmitt-trigger input. The polarity of the data strobe is programmable, but is configured as active-low ( $\overline{\text{HRD}}$ ) after reset.
PB11	Input or Output		<b>Port B 11</b> —When the HI08 is configured as GPIO through the HPCR, this signal is individually programmed as an input or output through the HDDR.

## Preliminary Information

## Signal/Connection Descriptions

### Host Interface (HI08)

Table 1-11 Host Interface (Continued)

Signal Name	Type	State During Reset	Signal Description
$\overline{\text{HDS}}$ /HDS	Input	Input	<b>Host Data Strobe</b> —When HI08 is programmed to interface a single-data-strobe host bus and the HI function is selected, this signal is the Host Data Strobe (HDS) Schmitt-trigger input. The polarity of the data strobe is programmable, but is configured as active-low ( $\overline{\text{HDS}}$ ) following reset.
$\overline{\text{HWR}}$ /HWR	Input	Input	<b>Host Write Data</b> —When HI08 is programmed to interface a double-data-strobe host bus and the HI function is selected, this signal is the Host Write Data Strobe (HWR) Schmitt-trigger input. The polarity of the data strobe is programmable, but is configured as active-low ( $\overline{\text{HWR}}$ ) following reset.
PB12	Input or Output	Input	<b>Port B 12</b> —When the HI08 is configured as GPIO through the HPCR, this signal is individually programmed as an input or output through the HDDR.
HCS	Input	Input	<b>Host Chip Select</b> —When HI08 is programmed to interface a non-multiplexed host bus and the HI function is selected, this signal is the Host Chip Select (HCS) input. The polarity of the chip select is programmable, but is configured active-low ( $\overline{\text{HCS}}$ ) after reset.
HA10	Input	Input	<b>Host Address 10</b> —When HI08 is programmed to interface a multiplexed host bus and the HI function is selected, this signal is line 10 of the Host Address (HA10) input bus.
PB13	Input or Output	Input	<b>Port B 13</b> —When the HI08 is configured as GPIO through the HPCR, this signal is individually programmed as an input or output through the HDDR.

## Preliminary Information

Table 1-11 Host Interface (Continued)

Signal Name	Type	State During Reset	Signal Description
$\overline{\text{HREQ}}/\text{HREQ}$	Output	Input	<b>Host Request</b> —When HI08 is programmed to interface a single host request host bus and the HI function is selected, this signal is the Host Request (HREQ) output. The polarity of the host request is programmable, but is configured as active-low ( $\overline{\text{HREQ}}$ ) following reset. The host request may be programmed as a driven or open-drain output.
$\overline{\text{HTRQ}}/\text{HTRQ}$	Output		<b>Transmit Host Request</b> —When HI08 is programmed to interface a double host request host bus and the HI function is selected, this signal is the Transmit Host Request (HTRQ) output. The polarity of the host request is programmable, but is configured as active-low ( $\overline{\text{HTRQ}}$ ) following reset. The host request may be programmed as a driven or open-drain output.
PB14	Input or Output		<b>Port B 14</b> —When the HI08 is programmed to interface a multiplexed host bus and the signal is configured as GPIO through the HPCR, this signal is individually programmed as an input or output through the HDDR.
$\overline{\text{HACK}}/\text{HACK}$	Input	Input	<b>Host Acknowledge</b> —When HI08 is programmed to interface a single host request host bus and the HI function is selected, this signal is the Host Acknowledge (HACK) Schmitt-trigger input. The polarity of the host acknowledge is programmable, but is configured as active-low ( $\overline{\text{HACK}}$ ) after reset.
$\overline{\text{HRRQ}}/\text{HRRQ}$	Output		<b>Receive Host Request</b> —When HI08 is programmed to interface a double host request host bus and the HI function is selected, this signal is the Receive Host Request (HRRQ) output. The polarity of the host request is programmable, but is configured as active-low ( $\overline{\text{HRRQ}}$ ) after reset. The host request may be programmed as a driven or open-drain output.
PB15	Input or Output		<b>Port B 15</b> —When the HI08 is configured as GPIO through the HPCR, this signal is individually programmed as an input or output through the HDDR.

## Preliminary Information

**ENHANCED SYNCHRONOUS SERIAL INTERFACE 0 (ESSI0)**

There are two synchronous serial interfaces (ESSI0 and ESSI1) that provide a full-duplex serial port for serial communication with a variety of serial devices, including one or more industry-standard codecs, other DSPs, microprocessors, and peripherals which implement the Motorola Serial Peripheral Interface (SPI).

**Table 1-12** Enhanced Synchronous Serial Interface 0 (ESSI0)

Signal Name	Type	State During Reset	Signal Description
SC00  PC0	Input or Output	Input	<p><b>Serial Control 0</b>—The function of SC00 is determined by the selection of either Synchronous or Asynchronous mode. For Asynchronous mode, this signal will be used for the receive clock I/O (Schmitt-trigger input). For Synchronous mode, this signal is used either for Transmitter 1 output or for Serial I/O Flag 0.</p> <p><b>Port C 0</b>—The default configuration following reset is GPIO input PC0. When configured as PC0, signal direction is controlled through the Port Directions Register (PRR0). The signal can be configured as ESSI signal SC00 through the Port Control Register (PCR0).</p>
SC01  PC1	Input/Output  Input or Output	Input	<p><b>Serial Control 1</b>—The function of this signal is determined by the selection of either Synchronous or Asynchronous mode. For Asynchronous mode, this signal is the receiver frame sync I/O. For Synchronous mode, this signal is used either for Transmitter 2 output or for Serial I/O Flag 1.</p> <p><b>Port C 1</b>—The default configuration following reset is GPIO input PC1. When configured as PC1, signal direction is controlled through PRR0. The signal can be configured as an ESSI signal SC01 through PCR0.</p>

**Preliminary Information**

Table 1-12 Enhanced Synchronous Serial Interface 0 (ESSI0) (Continued)

Signal Name	Type	State During Reset	Signal Description
SC02	Input/Output	Input	<b>Serial Control Signal 2</b> —SC02 is used for frame sync I/O. SC02 is the frame sync for both the transmitter and receiver in Synchronous mode, and for the transmitter only in Asynchronous mode. When configured as an output, this signal is the internally generated frame sync signal. When configured as an input, this signal receives an external frame sync signal for the transmitter (and the receiver in synchronous operation).
PC2	Input or Output		<b>Port C 2</b> —The default configuration following reset is GPIO input PC2. When configured as PC2, signal direction is controlled through PRR0. The signal can be configured as an ESSI signal SC02 through PCR0.
SCK0	Input/Output	Input	<b>Serial Clock</b> —SCK0 is a bidirectional Schmitt-trigger input signal providing the serial bit rate clock for the ESSI. The SCK0 is a clock input or output used by both the transmitter and receiver in Synchronous modes, or by the transmitter in Asynchronous modes.  Although an external serial clock can be independent of and asynchronous to the DSP system clock, it must exceed the minimum clock cycle time of 6T (i.e., the system clock frequency must be at least three times the external ESSI clock frequency). The ESSI needs at least three DSP phases inside each half of the serial clock.
PC3	Input or Output		<b>Port C 3</b> —The default configuration following reset is GPIO input PC3. When configured as PC3, signal direction is controlled through PRR0. The signal can be configured as an ESSI signal SCK0 through PCR0.
SRD0	Input/Output	Input	<b>Serial Receive Data</b> —SRD0 receives serial data and transfers the data to the ESSI receive shift register. SRD0 is an input when data is being received.
PC4	Input or Output		<b>Port C 4</b> —The default configuration following reset is GPIO input PC4. When configured as PC4, signal direction is controlled through PRR0. The signal can be configured as an ESSI signal SRD0 through PCR0.

## Preliminary Information

**Signal/Connection Descriptions****Enhanced Synchronous Serial Interface 0 (ESSI0)****Table 1-12** Enhanced Synchronous Serial Interface 0 (ESSI0) (Continued)

Signal Name	Type	State During Reset	Signal Description
STD0	Input/Output	Input	<b>Serial Transmit Data</b> —STD0 is used for transmitting data from the serial transmit shift register. STD0 is an output when data is being transmitted.
PC5	Input or Output		<b>Port C 5</b> —The default configuration following reset is GPIO input PC5. When configured as PC5, signal direction is controlled through PRR0. The signal can be configured as an ESSI signal STD0 through PCR0.

**Preliminary Information**



**ENHANCED SYNCHRONOUS SERIAL INTERFACE 1 (ESSI1)****Table 1-13** Enhanced Synchronous Serial Interface 1 (ESSI1)

Signal Name	Type	State During Reset	Signal Description
SC10	Input or Output	Input	<b>Serial Control 0</b> —The function of SC10 is determined by the selection of either Synchronous or Asynchronous mode. For Asynchronous mode, this signal will be used for the receive clock I/O (Schmitt-trigger input). For Synchronous mode, this signal is used either for Transmitter 1 output or for Serial I/O Flag 0.
PD0	Input or Output		<b>Port D 0</b> —The default configuration following reset is GPIO input PD0. When configured as PD0, signal direction is controlled through the Port Directions Register (PRR1). The signal can be configured as an ESSI signal SC10 through the Port Control Register (PCR1).
SC11	Input/Output	Input	<b>Serial Control 1</b> —The function of this signal is determined by the selection of either Synchronous or Asynchronous mode. For Asynchronous mode, this signal is the receiver frame sync I/O. For Synchronous mode, this signal is used either for Transmitter 2 output or for Serial I/O Flag 1.
PD1	Input or Output		<b>Port D 1</b> —The default configuration following reset is GPIO input PD1. When configured as PD1, signal direction is controlled through PRR1. The signal can be configured as an ESSI signal SC11 through PCR1.
SC12	Input/Output	Input	<b>Serial Control Signal 2</b> —SC12 is used for frame sync I/O. SC12 is the frame sync for both the transmitter and receiver in Synchronous mode, and for the transmitter only in Asynchronous mode. When configured as an output, this signal is the internally generated frame sync signal. When configured as an input, this signal receives an external frame sync signal for the transmitter (and the receiver in Synchronous operation).
PD2	Input or Output		<b>Port D 2</b> —The default configuration following reset is GPIO input PD2. When configured as PD2, signal direction is controlled through PRR1. The signal can be configured as an ESSI signal SC12 through PCR1.

**Preliminary Information**

## Signal/Connection Descriptions

## Enhanced Synchronous Serial Interface 1 (ESSI1)

Table 1-13 Enhanced Synchronous Serial Interface 1 (ESSI1) (Continued)

Signal Name	Type	State During Reset	Signal Description
SCK1	Input/Output	Input	<p><b>Serial Clock</b>—SCK1 is a bidirectional Schmitt-trigger input signal providing the serial bit rate clock for the ESSI. The SCK1 is a clock input or output used by both the transmitter and receiver in Synchronous modes, or by the transmitter in Asynchronous modes.</p> <p>Although an external serial clock can be independent of and asynchronous to the DSP system clock, it must exceed the minimum clock cycle time of 6T (i.e., the system clock frequency must be at least three times the external ESSI clock frequency). The ESSI needs at least three DSP phases inside each half of the serial clock.</p>
PD3	Input or Output		<p><b>Port D 3</b>—The default configuration following reset is GPIO input PD3. When configured as PD3, signal direction is controlled through PRR1. The signal can be configured as an ESSI signal SCK1 through PCR1.</p>
SRD1	Input/Output	Input	<p><b>Serial Receive Data</b>—SRD1 receives serial data and transfers the data to the ESSI receive shift register. SRD1 is an input when data is being received.</p>
PD4	Input or Output		<p><b>Port D 4</b>—The default configuration following reset is GPIO input PD4. When configured as PD4, signal direction is controlled through PRR1. The signal can be configured as an ESSI signal SRD1 through PCR1.</p>
STD1	Input/Output	Input	<p><b>Serial Transmit Data</b>—STD1 is used for transmitting data from the serial transmit shift register. STD1 is an output when data is being transmitted.</p>
PD5	Input or Output		<p><b>Port D 5</b>—The default configuration following reset is GPIO input PD5. When configured as PD5, signal direction is controlled through PRR1. The signal can be configured as an ESSI signal STD1 through PCR1.</p>

## Preliminary Information

**SERIAL COMMUNICATION INTERFACE (SCI)**

The Serial Communication interface (SCI) provides a full duplex port for serial communication to other DSPs, microprocessors, or peripherals such as modems.

**Table 1-14** Serial Communication Interface (SCI)

Signal Name	Type	State During Reset	Signal Description
RXD	Input	Input	<b>Serial Receive Data</b> —This input receives byte oriented serial data and transfers it to the SCI receive shift register.
PE0	Input or Output		<b>Port E 0</b> —The default configuration following reset is GPIO input PE0. When configured as PE0, signal direction is controlled through the SCI Port Directions Register (PRR). The signal can be configured as an SCI signal RXD through the SCI Port Control Register (PCR).
TXD	Output	Input	<b>Serial Transmit Data</b> —This signal transmits data from SCI transmit data register.
PE1	Input or Output		<b>Port E 1</b> —The default configuration following reset is GPIO input PE1. When configured as PE1, signal direction is controlled through the SCI PRR. The signal can be configured as an SCI signal TXD through the SCI PCR.
SCLK	Input/Output	Input	<b>Serial Clock</b> —This is the bidirectional Schmitt-trigger input signal providing the input or output clock used by the transmitter and/or the receiver.
PE2	Input or Output		<b>Port E 2</b> —The default configuration following reset is GPIO input PE2. When configured as PE2, signal direction is controlled through the SCI PRR. The signal can be configured as an SCI signal SCLK through the SCI PCR.

**Preliminary Information**

## TIMERS

Three identical and independent timers are implemented in the DSP56302A. Each timer can use internal or external clocking, and can interrupt the DSP56302A after a specified number of events (clocks), or can signal an external device after counting a specific number of internal events.

Table 1-15 Triple Timer Signals

Signal Name	Type	State During Reset	Signal Description
TIO0	Input or Output	Input	<p><b>Timer 0 Schmitt-Trigger Input/Output</b>—When Timer 0 functions as an external event counter or in Measurement mode, TIO0 is used as input. When Timer 0 functions in Watchdog, Timer, or Pulse Modulation mode, TIO0 is used as output.</p> <p>The default mode after reset is GPIO input. This can be changed to output or configured as a Timer Input/Output through the Timer 0 Control/Status Register (TCSR0).</p>
TIO1	Input or Output	Input	<p><b>Timer 1 Schmitt-Trigger Input/Output</b>—When Timer 1 functions as an external event counter or in Measurement mode, TIO1 is used as input. When Timer 1 functions in Watchdog, Timer, or Pulse Modulation mode, TIO1 is used as output.</p> <p>The default mode after reset is GPIO input. This can be changed to output or configured as a Timer Input/Output through the Timer 1 Control/Status Register (TCSR1).</p>
TIO2	Input or Output	Input	<p><b>Timer 2 Schmitt-Trigger Input/Output</b>—When Timer 2 functions as an external event counter or in Measurement mode, TIO2 is used as input. When Timer 2 functions in Watchdog, Timer, or Pulse Modulation mode, TIO2 is used as output.</p> <p>The default mode after reset is GPIO input. This can be changed to output or configured as a Timer Input/Output through the Timer 2 Control/Status Register (TCSR2).</p>

## Preliminary Information

**OnCE/JTAG INTERFACE**

Table 1-16 OnCE/JTAG Interface

Signal Name	Type	State During Reset	Signal Description
TCK	Input	Input	<b>Test Clock</b> —TCK is a test clock input signal used to synchronize the JTAG test logic.
TDI	Input	Input	<b>Test Data Input</b> —TDI is a test data serial input signal used for test instructions and data. TDI is sampled on the rising edge of TCK and has an internal pull-up resistor.
TDO	Output	Tri-stated	<b>Test Data Output</b> —TDO is a test data serial output signal used for test instructions and data. TDO is tri-statable and is actively driven in the shift-IR and shift-DR controller states. TDO changes on the falling edge of TCK.
TMS	Input	Input	<b>Test Mode Select</b> —TMS is an input signal used to sequence the test controller's state machine. TMS is sampled on the rising edge of TCK and has an internal pull-up resistor.
$\overline{\text{TRST}}$	Input	Input	<b>Test Reset</b> — $\overline{\text{TRST}}$ is an active-low Schmitt-trigger input signal used to asynchronously initialize the test controller. $\overline{\text{TRST}}$ has an internal pull-up resistor. $\overline{\text{TRST}}$ must be asserted after power up.

**Preliminary Information**

Signal/Connection Descriptions

OnCE/JTAG Interface

Table 1-16 OnCE/JTAG Interface (Continued)

Signal Name	Type	State During Reset	Signal Description
$\overline{DE}$	Input/Output	Input	<p><b>Debug Event</b>—<math>\overline{DE}</math> is an open-drain, bidirectional, active-low signal providing, as an input, a means of entering the Debug mode of operation from an external command controller, and, as an output, a means of acknowledging that the chip has entered the Debug mode. This signal, when asserted as an input, causes the DSP56300 core to finish the current instruction being executed, save the instruction pipeline information, enter the Debug mode, and wait for commands to be entered from the debug serial input line. This signal is asserted as an output for three clock cycles when the chip enters the Debug mode as a result of a debug request or as a result of meeting a breakpoint condition. The <math>\overline{DE}</math> has an internal pull-up resistor.</p> <p>This is not a standard part of the JTAG Test Access Port (TAP) Controller. The signal connects directly to the OnCE module to initiate Debug mode directly or to provide a direct external indication that the chip has entered the Debug mode. All other interface with the OnCE module must occur through the JTAG port.</p>



Preliminary Information

# SECTION 2

## SPECIFICATIONS

---

### INTRODUCTION

The DSP56302A is fabricated in high density CMOS with Transistor-Transistor Logic (TTL) compatible inputs and outputs. The DSP56302A specifications are preliminary and are from design simulations, and may not be fully tested or guaranteed at this early stage of the product life cycle. Finalized specifications will be published after full characterization and device qualifications are complete.

### MAXIMUM RATINGS

#### CAUTION

**This device contains circuitry protecting against damage due to high static voltage or electrical fields; however, normal precautions should be taken to avoid exceeding maximum voltage ratings. Reliability is enhanced if unused inputs are tied to an appropriate logic voltage level (e.g., either GND or  $V_{CC}$ ).**

**Note:** In the calculation of timing requirements, adding a maximum value of one specification to a minimum value of another specification does not yield a reasonable sum. A maximum specification is calculated using a worst case variation of process parameter values in one direction. The minimum specification is calculated using the worst case for the same parameters in the opposite direction. Therefore, a "maximum" value for a specification will never occur in the same device that has a "minimum" value for another specification; adding a maximum to a minimum represents a condition that can never exist.

Preliminary Information

## Specifications

### Thermal Characteristics

**Table 2-1** Maximum Ratings

Rating <sup>1</sup>	Symbol	Value <sup>1, 2</sup>	Unit
Supply Voltage	$V_{CC}$	-0.3 to +4.0	V
All input voltages	$V_{IN}$	GND - 0.3 to $V_{CC} + 0.3$	V
Current drain per pin excluding $V_{CC}$ and GND	I	10	mA
Operating temperature range	$T_J$	-40 to +100	°C
Storage temperature	$T_{STG}$	-55 to +150	°C

Notes: 1. GND = 0 V,  $V_{CC} = 3.3 \text{ V} \pm 0.3 \text{ V}$ ,  $T_J = -40^\circ\text{C}$  to  $+100^\circ\text{C}$ , CL = 50 pF  
 2. Absolute maximum ratings are stress ratings only, and functional operation at the maximum is not guaranteed. Stress beyond the maximum rating may affect device reliability or cause permanent damage to the device.

## THERMAL CHARACTERISTICS

**Table 2-2** Thermal Characteristics

Characteristic	Symbol	TQFP Value	PBGA <sup>3</sup> Value	PBGA <sup>4</sup> Value	Unit
Junction-to-ambient thermal resistance <sup>1</sup>	$R_{\theta JA}$ or $\theta_{JA}$	49.3	49.4	28.5	°C/W
Junction-to-case thermal resistance <sup>2</sup>	$R_{\theta JC}$ or $\theta_{JC}$	8.2	12.0	—	°C/W
Thermal characterization parameter	$\Psi_{JT}$	5.5	2.0	—	°C/W

Notes: 1. Junction-to-ambient thermal resistance is based on measurements on a horizontal single-sided Printed Circuit Board per SEMI G38-87 in natural convection. (SEMI is Semiconductor Equipment and Materials International, 805 East Middlefield Rd., Mountain View, CA 94043, (415) 964-5111) Measurements were done with parts mounted on thermal test boards conforming to specification EIA/JESD51-3.  
 2. Junction-to-case thermal resistance is based on measurements using a cold plate per SEMI G30-88, with the exception that the cold plate temperature is used for the case temperature.  
 3. These are simulated values; testing is not complete. See Note 1 for test board conditions.  
 4. These are simulated values; testing is not complete. The test board has two, 2-ounce signal layers and two 1-ounce solid ground planes internal to the test board.

### Preliminary Information



## DC ELECTRICAL CHARACTERISTICS

Table 2-3 DC Electrical Characteristics<sup>1</sup>

Characteristics	Symbol	Min	Typ	Max	Unit
Supply voltage	$V_{CC}$	3.0	3.3	3.6	V
Input high voltage	$V_{IH}$	2.0	—	$V_{CC}$	V
• D0–D23, $\overline{BG}$ , $\overline{BB}$ , $\overline{TA}$	$V_{IHP}$	2.0	—	$V_{CC} + 0.3$	V
• $MOD^2/\overline{IRQ}^2$ , RESET, PINIT/ $\overline{NMI}$ and all JTAG/ESSI/SCI/Timer/HI08 pins	$V_{IHX}$	$0.8 \times V_{CC}$	—	$V_{CC}$	V
• EXTAL <sup>3</sup>					
Input low voltage	$V_{IL}$	–0.3	—	0.8	V
• D0–D23, $\overline{BG}$ , $\overline{BB}$ , $\overline{TA}$ , $MOD^2/\overline{IRQ}^2$ , RESET, PINIT	$V_{ILP}$	–0.3	—	0.8	V
• All JTAG/ESSI/SCI/Timer/HI08 pins	$V_{ILX}$	–0.3	—	$0.2 \times V_{CC}$	V
• EXTAL <sup>3</sup>					
Input leakage current	$I_{IN}$	–10	—	10	$\mu A$
High impedance (off-state) input current (@ 2.4 V / 0.4 V)	$I_{TSI}$	–10	—	10	$\mu A$
Output high voltage	$V_{OH}$	$V_{CC} - 0.4$	—	—	V
• TTL ( $I_{OH} = -0.4$ mA) <sup>4,5</sup>		$V_{CC} - 0.01$	—	—	V
• CMOS ( $I_{OH} = -10$ $\mu A$ ) <sup>4</sup>					
Output low voltage	$V_{OL}$	—	—	0.4	V
• TTL (Port A $I_{OL} = 1.6$ mA, non-Port A $I_{OL} = 3.2$ mA, open-drain pins $I_{OL} = 6.7$ mA) <sup>4,5</sup>		—	—	0.01	V
• CMOS ( $I_{OL} = 10$ $\mu A$ ) <sup>4</sup>					
Internal supply current <sup>6</sup> :					
• In Normal mode	$I_{CCI}$	—	66 MHz: 106 80 MHz: 128 100 MHz: 160	—	mA mA mA
• In Wait mode <sup>7</sup>	$I_{CCW}$	—	5	—	mA
• In Stop mode <sup>8</sup>	$I_{CCS}$	—	100	—	$\mu A$
PLL supply current in Stop mode <sup>4</sup>		—	1	2.5	mA
Input capacitance <sup>4</sup>	$C_{IN}$	—	—	10	pF

## Preliminary Information

## Specifications

### AC Electrical Characteristics

Table 2-3 DC Electrical Characteristics<sup>1</sup> (Continued)

Characteristics	Symbol	Min	Typ	Max	Unit
Notes:					
1.	$V_{CC} = 3.3 \text{ V} \pm 0.3 \text{ V}$ ; $T_J = -40^\circ\text{C}$ to $+100^\circ\text{C}$ , $C_L = 50 \text{ pF}$				
2.	Refers to MODA/ $\overline{\text{IRQA}}$ , MODB/ $\overline{\text{IRQB}}$ , MODC/ $\overline{\text{IRQC}}$ , and MODD/ $\overline{\text{IRQD}}$ pins				
3.	Driving EXTAL to the low $V_{IHx}$ or the high $V_{ILx}$ value may cause additional power consumption (dc current). To minimize power consumption, the minimum $V_{IHx}$ should be no lower than $0.9 \times V_{CC}$ and the maximum $V_{ILx}$ should be no higher than $0.1 \times V_{CC}$ .				
4.	Periodically sampled and not 100% tested				
5.	This characteristic does not apply to XTAL and PCAP.				
6.	<b>Power Consumption Considerations</b> on page 4-4 provides a formula to compute the estimated current requirements in Normal mode. In order to obtain these results, all inputs must be terminated (i.e., not allowed to float). Measurements are based on synthetic intensive DSP benchmarks (see <b>Appendix A</b> ). The power consumption numbers in this specification are 90% of the measured results of this benchmark. This reflects typical DSP applications. Typical internal supply current is measured with $V_{CC} = 3.3 \text{ V}$ at $T_J = 100^\circ\text{C}$ . Maximum internal supply current may vary widely and is application dependent.				
7.	In order to obtain these results, all inputs must be terminated (i.e., not allowed to float). PLL and XTAL signals are disabled during Stop state.				
8.	In order to obtain these results, all inputs, which are not disconnected at Stop mode, must be terminated (i.e., not allowed to float).				

## AC ELECTRICAL CHARACTERISTICS

The timing waveforms shown in the ac electrical characteristics section are tested with a  $V_{IL}$  maximum of 0.3 V and a  $V_{IH}$  minimum of 2.4 V for all pins except EXTAL, which is tested using the input levels shown in **Note 6** of the previous table. AC timing specifications, which are referenced to a device input signal, are measured in production with respect to the 50% point of the respective input signal's transition. DSP56302A output levels are measured with the production test machine  $V_{OL}$  and  $V_{OH}$  reference levels set at 0.8 V and 2.0 V, respectively.

### Preliminary Information

## INTERNAL CLOCKS

Table 2-4 Internal Clocks, CLKOUT

Characteristics	Symbol	Expression <sup>1, 2</sup>		
		Min	Typ	Max
Internal operation frequency and CLKOUT with PLL enabled	f	—	$(Ef \times MF) / (PDF \times DF)$	—
Internal operation frequency and CLKOUT with PLL disabled	f	—	$Ef/2$	—
Internal clock and CLKOUT high period <ul style="list-style-type: none"> <li>• With PLL disabled</li> <li>• With PLL enabled and <math>MF \leq 4</math></li> <li>• With PLL enabled and <math>MF &gt; 4</math></li> </ul>	$T_H$	— $0.49 \times ET_C \times PDF \times DF / MF$ $0.47 \times ET_C \times PDF \times DF / MF$	$ET_C$ — —	— $0.51 \times ET_C \times PDF \times DF / MF$ $0.53 \times ET_C \times PDF \times DF / MF$
Internal clock and CLKOUT low period <ul style="list-style-type: none"> <li>• With PLL disabled</li> <li>• With PLL enabled and <math>MF \leq 4</math></li> <li>• With PLL enabled and <math>MF &gt; 4</math></li> </ul>	$T_L$	— $0.49 \times ET_C \times PDF \times DF / MF$ $0.47 \times ET_C \times PDF \times DF / MF$	$ET_C$ — —	— $0.51 \times ET_C \times PDF \times DF / MF$ $0.53 \times ET_C \times PDF \times DF / MF$
Internal clock and CLKOUT cycle time with PLL enabled	$T_C$	—	$ET_C \times PDF \times DF / MF$	—
Internal clock and CLKOUT cycle time with PLL disabled	$T_C$	—	$2 \times ET_C$	—
Instruction cycle time	$I_{CVC}$	—	$T_C$	—
Notes: 1. DF = Division Factor Ef = External frequency $ET_C$ = External clock cycle MF = Multiplication Factor PDF = Predivision Factor $T_C$ = internal clock cycle 2. See the <b>PLL and Clock Generation</b> section in the <i>DSP56300 Family Manual</i> for a detailed discussion of the PLL.				

## Preliminary Information

## Specifications

### EXTERNAL CLOCK OPERATION

## EXTERNAL CLOCK OPERATION

The DSP56302A system clock may be derived from the on-chip crystal oscillator, as shown in **Figure 1** on the cover page, or it may be externally supplied. An externally supplied square wave voltage source should be connected to EXTAL (see **Figure 2-2**), leaving XTAL physically not connected to the board or socket.

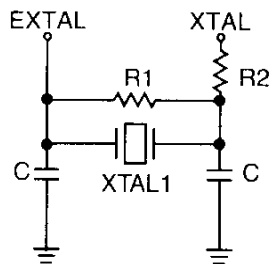

**Fundamental Frequency  
Fork Crystal Oscillator**

#### Suggested Component Values:

$f_{osc} = 32.768 \text{ kHz}$   
 $R1 = 3.9 \text{ M}\Omega \pm 10\%$   
 $C = 22 \text{ pF} \pm 20\%$   
 $R2 = 200 \text{ k}\Omega \pm 10\%$

Calculations were done for a 32.768 kHz crystal with the following parameters:  
a load capacitance ( $C_L$ ) of 12.5 pF,  
a shunt capacitance ( $C_0$ ) of 1.8 pF,  
a series resistance of 40 k $\Omega$ , and  
a drive level of 1  $\mu$ W.

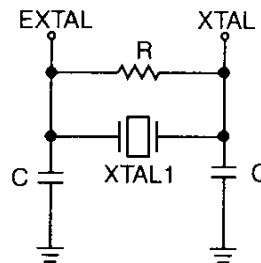

**Fundamental Frequency  
Crystal Oscillator**

#### Suggested Component Values:

$f_{osc} = 4 \text{ MHz}$        $f_{osc} = 20 \text{ MHz}$   
 $R = 680 \text{ k}\Omega \pm 10\%$        $R = 680 \text{ k}\Omega \pm 10\%$   
 $C = 56 \text{ pF} \pm 20\%$        $C = 22 \text{ pF} \pm 20\%$

Calculations were done for a 4/20 MHz crystal with the following parameters:  
a  $C_L$  of 30/20 pF,  
a  $C_0$  of 7/6 pF,  
a series resistance of 100/20  $\Omega$ , and  
a drive level of 2 mW.

AA1071

**Figure 2-1** Crystal Oscillator Circuits

## Preliminary Information

EXTERNAL CLOCK OPERATION

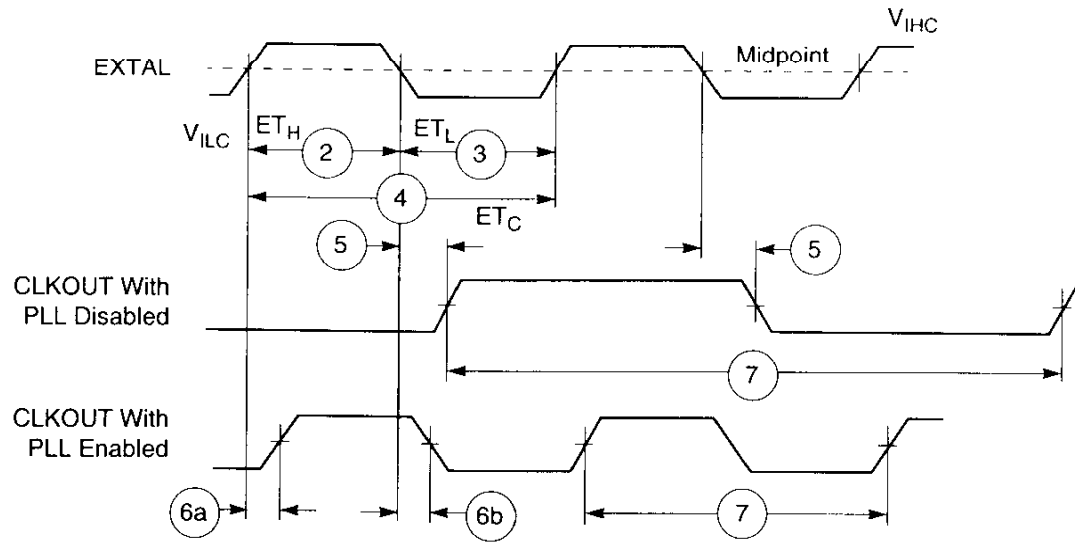

Note: The midpoint is  $0.5(V_{IHC} + V_{ILC})$ .

AA0459

Figure 2-2 External Clock Timing

Table 2-5 Clock Operation

No.	Characteristics	Symbol	66 MHz		80 MHz		100 MHz	
			Min	Max	Min	Max	Min	Max
1	Frequency of EXTAL (EXTAL Pin Frequency) The rise and fall time of this external clock should be 3 ns maximum.	$E_f$	0	66.0	0	80.0	0	100.0
2	EXTAL input high <sup>1,2</sup> • With PLL disabled (46.7%–53.3% duty cycle <sup>6</sup> ) • With PLL enabled (42.5%–57.5% duty cycle <sup>6</sup> )	$ET_H$	7.08 ns	$\infty$	5.84 ns	$\infty$	4.67 ns	$\infty$
3	EXTAL input low <sup>1,2</sup> • With PLL disabled (46.7%–53.3% duty cycle <sup>6</sup> ) • With PLL enabled (42.5%–57.5% duty cycle <sup>6</sup> )	$ET_L$	7.08 ns	$\infty$	5.84 ns	$\infty$	4.67 ns	$\infty$

Preliminary Information

Specifications

EXTERNAL CLOCK OPERATION

Table 2-5 Clock Operation (Continued)

No.	Characteristics	Symbol	66 MHz		80 MHz		100 MHz	
			Min	Max	Min	Max	Min	Max
4	EXTAL cycle time <sup>2</sup> <ul style="list-style-type: none"> <li>• With PLL disabled</li> <li>• With PLL enabled</li> </ul>	$ET_C$	15.15 ns 15.15 ns	$\infty$ 273.1 $\mu$ s	12.50 ns 12.50 ns	$\infty$ 273.1 $\mu$ s	10.00 ns 10.00 ns	$\infty$ 273.1 $\mu$ s
5	CLKOUT change from EXTAL fall with PLL disabled		4.3 ns	11.0 ns	4.3 ns	11.0 ns	4.3 ns	11.0 ns
6	CLKOUT rising edge from EXTAL rising edge with PLL enabled (MF = 1, PDF = 1, Ef > 15 MHz) <sup>3,5</sup>		0.0 ns	1.8 ns	0.0 ns	1.8 ns	0.0 ns	1.8 ns
	CLKOUT falling edge from EXTAL rising edge with PLL enabled (MF = 2 or 4, PDF = 1, Ef > 15 MHz) <sup>3,5</sup>		0.0 ns	1.8 ns	0.0 ns	1.8 ns	0.0 ns	1.8 ns
	CLKOUT falling edge from EXTAL falling edge with PLL enabled (MF $\leq$ 4, PDF $\neq$ 1, Ef/PDF > 15 MHz) <sup>3,5</sup>		0.0 ns	1.8 ns	0.0 ns	1.8 ns	0.0 ns	1.8 ns
7	Instruction cycle time = $I_{CYC} = T_C^4$ (see Table 2-4) (46.7%–53.3% duty cycle) <ul style="list-style-type: none"> <li>• With PLL disabled</li> <li>• With PLL enabled</li> </ul>	$I_{CYC}$	30.3 ns 15.15 ns	$\infty$ 8.53 $\mu$ s	25.0 ns 12.50 ns	$\infty$ 8.53 $\mu$ s	20.0 ns 10.00 ns	$\infty$ 8.53 $\mu$ s

Notes: 1. Measured at 50% of the input transition  
2. The maximum value for PLL enabled is given for minimum  $V_{CO}$  and maximum MF.  
3. Periodically sampled and not 100% tested  
4. The maximum value for PLL enabled is given for minimum  $V_{CO}$  and maximum DF.  
5. The skew is not guaranteed for any other MF value.  
6. The indicated duty cycle is for the specified maximum frequency for which a part is rated. The minimum clock high or low time required for correction operation, however, remains the same at lower operating frequencies; therefore, when a lower clock frequency is used, the signal symmetry may vary from the specified duty cycle as long as the minimum high time and low time requirements are met.

Preliminary Information

## PHASE LOCK LOOP (PLL) CHARACTERISTICS

Table 2-6 PLL Characteristics

Characteristics	66 MHz		80 MHz		100 MHz		Unit
	Min	Max	Min	Max	Min	Max	
$V_{CO}$ frequency when PLL enabled ( $MF \times E_f \times 2/PDF$ )	30	132	30	160	30	200	MHz
PLL external capacitor (PCAP pin to $V_{CCP}$ ) ( $C_{PCAP}^1$ )							
• @ $MF \leq 4$	$(MF \times 425) - 125$	$(MF \times 590) - 175$	$(MF \times 425) - 125$	$(MF \times 590) - 175$	$(MF \times 425) - 125$	$(MF \times 590) - 175$	pF
• @ $MF > 4$	$MF \times 520$	$MF \times 920$	$MF \times 520$	$MF \times 920$	$MF \times 520$	$MF \times 920$	pF
Note: $C_{PCAP}$ is the value of the PLL capacitor (connected between the PCAP pin and $V_{CCP}$ ). The recommended value in pF for $C_{PCAP}$ can be computed from one of the following equations: $(680 \times MF) - 120$ , for $MF < 3$ , or $1100 \times MF$ , for $MF \geq 3$ .							

### Preliminary Information

## Specifications

### Reset, Stop, Mode Select, and Interrupt Timing

## RESET, STOP, MODE SELECT, AND INTERRUPT TIMING

Table 2-7 Reset, Stop, Mode Select, and Interrupt Timing<sup>6</sup>

No.	Characteristics	Expression	66 MHz		80 MHz		100 MHz		Unit
			Min	Max	Min	Max	Min	Max	
8	Delay from $\overline{\text{RESET}}$ assertion to all pins at reset value <sup>3</sup>	—	—	26.0	—	26.0	—	26.0	ns
9	Required $\overline{\text{RESET}}$ duration <sup>4</sup> <ul style="list-style-type: none"> <li>• Power on, external clock generator, PLL disabled</li> <li>• Power on, external clock generator, PLL enabled</li> <li>• Power on, internal oscillator</li> <li>• During STOP, XTAL disabled (PCTL Bit 16 = 0)</li> <li>• During STOP, XTAL enabled (PCTL Bit 16 = 1)</li> <li>• During normal operation</li> </ul>	$50 \times \text{ET}_C$	760.0	—	625.0	—	500.0	—	ns
		$1000 \times \text{ET}_C$	15.2	—	12.5	—	10.0	—	$\mu\text{s}$
		$75000 \times \text{ET}_C$	1.14	—	1.0	—	0.75	—	ms
		$75000 \times \text{ET}_C$	1.14	—	1.0	—	0.75	—	ms
		$2.5 \times \text{T}_C$	38.0	—	31.3	—	25.0	—	ns
		$2.5 \times \text{T}_C$	38.0	—	31.3	—	25.0	—	ns
10	Delay from asynchronous $\overline{\text{RESET}}$ deassertion to first external address output (internal reset deassertion) <sup>5</sup> <ul style="list-style-type: none"> <li>• Minimum</li> <li>• Maximum</li> </ul>	<b>66 MHz:</b> $3.25 \times \text{T}_C + 2.0$	51.0	—	—	—	—	—	ns
		<b>80 MHz:</b> $3.25 \times \text{T}_C + 2.0$	—	—	42.6	—	—	—	ns
		<b>100 MHz:</b> $3.25 \times \text{T}_C + 2.0$	—	—	—	—	34.5	—	ns
		<b>66 MHz:</b> $20.25 \text{T}_C + 11.0$	—	318.0	—	—	—	—	ns
		<b>80 MHz:</b> $20.25 \text{T}_C + 9.95$	—	—	—	263.1	—	—	ns
		<b>100 MHz:</b> $20.25 \text{T}_C + 7.50$	—	—	—	—	—	211.5	ns

### Preliminary Information



Table 2-7 Reset, Stop, Mode Select, and Interrupt Timing<sup>6</sup> (Continued)

No.	Characteristics	Expression	66 MHz		80 MHz		100 MHz		Unit
			Min	Max	Min	Max	Min	Max	
11	Synchronous reset setup time from $\overline{\text{RESET}}$ deassertion to CLKOUT Transition 1 • Minimum • Maximum	$T_C$	9.0	—	7.4	—	5.9	—	ns
			—	15.2	—	12.5	—	10.0	ns
12	Synchronous reset deasserted, delay time from the CLKOUT Transition 1 to the first external address output • Minimum • Maximum	$3.25 \times T_C + 1.0$	50.0	—	41.6	—	33.5	—	ns
		$20.25 T_C + 5.0$	—	312.0	—	258.1	—	207.5	ns
13	Mode select setup time		30.0	—	30.0	—	30.0	—	ns
14	Mode select hold time		0.0	—	0.0	—	0.0	—	ns
15	Minimum edge-triggered interrupt request assertion width		10.0	—	8.25	—	6.6	—	ns
16	Minimum edge-triggered interrupt request deassertion width		10.0	—	8.25	—	6.6	—	ns
17	Delay from $\overline{\text{IRQA}}$ , $\overline{\text{IRQB}}$ , $\overline{\text{IRQC}}$ , $\overline{\text{IRQD}}$ , $\overline{\text{NMI}}$ assertion to external memory access address out valid • Caused by first interrupt instruction fetch • Caused by first interrupt instruction execution	$4.25 \times T_C + 2.0$	66.0	—	55.1	—	44.5	—	ns
		$7.25 \times T_C + 2.0$	112.0	—	92.6	—	74.5	—	ns

## Preliminary Information

## Specifications

### Reset, Stop, Mode Select, and Interrupt Timing

Table 2-7 Reset, Stop, Mode Select, and Interrupt Timing<sup>6</sup> (Continued)

No.	Characteristics	Expression	66 MHz		80 MHz		100 MHz		Unit
			Min	Max	Min	Max	Min	Max	
18	Delay from $\overline{\text{IRQA}}$ , $\overline{\text{IRQB}}$ , $\overline{\text{IRQC}}$ , $\overline{\text{IRQD}}$ , NMI assertion to general-purpose transfer output valid caused by first interrupt instruction execution	$10 \times T_C + 5.0$	157.0	—	130.0	—	105.0	—	ns
19	Delay from address output valid caused by first interrupt instruction execute to interrupt request deassertion for level sensitive fast interrupts <sup>1</sup>	<b>66 MHz<sup>8</sup>:</b> $3.75 \times T_C + WS \times T_C - 14$	—						ns
		<b>80 MHz<sup>8</sup>:</b> $3.75 \times T_C + WS \times T_C - 12.4$			—				ns
		<b>100 MHz<sup>8</sup>:</b> $3.75 \times T_C + WS \times T_C - 10.94$					—		ns
20	Delay from $\overline{\text{RD}}$ assertion to interrupt request deassertion for level sensitive fast interrupts <sup>1</sup>	<b>66 MHz<sup>8</sup>:</b> $3.25 \times T_C + WS \times T_C - 14$	—						ns
		<b>80 MHz<sup>8</sup>:</b> $3.25 \times T_C + WS \times T_C - 12.4$			—				ns
		<b>100 MHz<sup>8</sup>:</b> $3.25 \times T_C + WS \times T_C - 10.94$					—		ns

### Preliminary Information

Table 2-7 Reset, Stop, Mode Select, and Interrupt Timing<sup>6</sup> (Continued)

No.	Characteristics	Expression	66 MHz		80 MHz		100 MHz		Unit	
			Min	Max	Min	Max	Min	Max		
21	Delay from $\overline{WR}$ assertion to interrupt request deassertion for level sensitive fast interrupts <sup>1</sup> <ul style="list-style-type: none"> <li>• DRAM for all WS</li> <li>• SRAM WS = 1</li> <li>• SRAM WS = 2, 3</li> <li>• SRAM WS ≥ 4</li> </ul>	<b>66 MHz<sup>8</sup>:</b> $(WS + 3.5) \times T_C - 14$	—						ns	
		<b>80 MHz<sup>8</sup>:</b> $(WS + 3.5) \times T_C - 12.4$			—					ns
		<b>100 MHz<sup>8</sup>:</b> $(WS + 3.5) \times T_C - 10.94$					—			ns
		<b>66 MHz<sup>8</sup>:</b> $(WS + 3.5) \times T_C - 14$	—							ns
		<b>80 MHz<sup>8</sup>:</b> $(WS + 3.5) \times T_C - 12.4$			—					ns
		<b>100 MHz<sup>8</sup>:</b> $(WS + 3.5) \times T_C - 10.94$					—			ns
		<b>66 MHz<sup>8</sup>:</b> $(WS + 3) \times T_C - 14$	—							ns
		<b>80 MHz<sup>8</sup>:</b> $(WS + 3) \times T_C - 12.4$			—					ns
		<b>100 MHz<sup>8</sup>:</b> $(WS + 3) \times T_C - 10.94$					—			ns
		<b>66 MHz<sup>8</sup>:</b> $(WS + 2.5) \times T_C - 14$	—							ns
		<b>80 MHz<sup>8</sup>:</b> $(WS + 2.5) \times T_C - 12.4$			—					ns
		<b>100 MHz<sup>8</sup>:</b> $(WS + 2.5) \times T_C - 10.94$					—			ns
22	Synchronous interrupt setup time from $\overline{IRQA}$ , $\overline{IRQB}$ , $\overline{IRQC}$ , $\overline{IRQD}$ , $\overline{NMI}$ assertion to the CLKOUT Transition 2		9.0	$T_C$	7.4	$T_C$	5.9	$T_C$	ns	

Specifications

Reset, Stop, Mode Select, and Interrupt Timing

Table 2-7 Reset, Stop, Mode Select, and Interrupt Timing<sup>b</sup> (Continued)

No.	Characteristics	Expression	66 MHz		80 MHz		100 MHz		Unit
			Min	Max	Min	Max	Min	Max	
23	Synchronous interrupt delay time from the CLKOUT Transition 2 to the first external address output valid caused by the first instruction fetch after coming out of Wait Processing state <ul style="list-style-type: none"> <li>• Minimum</li> <li>• Maximum</li> </ul>	$9.25 \times T_C + 1.0$	141.0	—	116.6	—	93.5	—	ns
		$24.75 \times T_C + 5.0$	—	380.0	—	314.4	—	252.5	ns
24	Duration for $\overline{IRQA}$ assertion to recover from Stop state		9.0	—	7.4	—	5.9	—	ns
25	Delay from $\overline{IRQA}$ assertion to fetch of first instruction (when exiting Stop) <sup>2,3</sup> <ul style="list-style-type: none"> <li>• PLL is not active during Stop (PCTL Bit 17 = 0) and Stop delay is enabled (OMR Bit 6 = 0)</li> <li>• PLL is not active during Stop (PCTL Bit 17 = 0) and Stop delay is not enabled (OMR Bit 6 = 1)</li> <li>• PLL is active during Stop (PCTL Bit 17 = 1) (Implies No Stop Delay)</li> </ul>	$PLC \times ET_C \times PDF + (128 K - PLC/2) \times T_C$	2.0	64.1	1.6	17.0	1.3	13.6	ms
		$PLC \times ET_C \times PDF + (23.75 \pm 0.5) \times T_C$	352.3 ns	62.1 ms	290.6 ns	15.4 ms	232.5 ns	12.3 ms	
		$(8.25 \pm 0.5) \times T_C$	117.4	132.6	96.9	109.4	77.5	87.5	ns

Preliminary Information

Table 2-7 Reset, Stop, Mode Select, and Interrupt Timing<sup>6</sup> (Continued)

No.	Characteristics	Expression	66 MHz		80 MHz		100 MHz		Unit
			Min	Max	Min	Max	Min	Max	
26	Duration of level sensitive IRQA assertion to ensure interrupt service (when exiting Stop) <sup>2,3</sup> <ul style="list-style-type: none"> <li>• PLL is not active during Stop (PCTL Bit 17 = 0) and Stop delay is enabled (OMR Bit 6 = 0)</li> <li>• PLL is not active during Stop (PCTL Bit 17 = 0) and Stop delay is not enabled (OMR Bit 6 = 1)</li> <li>• PLL is active during Stop (PCTL Bit 17 = 1) (implies no Stop delay)</li> </ul>	$PLC \times ET_C \times PDF + (128K - PLC/2) \times T_C$	64.1	—	17.0	—	13.6	—	ms
		$PLC \times ET_C \times PDF + (20.5 \pm 0.5) \times T_C$	62.1	—	15.4	—	12.3	—	ms
		$5.5 \times T_C$	83.4	—	68.8	—	55.0	—	ns
27	Interrupt Requests Rate <ul style="list-style-type: none"> <li>• HI08, ESSI, SCI, Timer</li> <li>• DMA</li> <li>• <math>\overline{IRQ}</math>, <math>\overline{NMI}</math> (edge trigger)</li> <li>• <math>\overline{IRQ}</math>, <math>\overline{NMI}</math> (level trigger)</li> </ul>	$12T_C$	—	181.8	—	150.0	—	120.0	ns
		$8T_C$	—	121.2	—	100.0	—	80.0	ns
		$8T_C$	—	121.2	—	100.0	—	80.0	ns
		$12T_C$	—	181.8	—	150.0	—	120.0	ns
28	DMA Requests Rate <ul style="list-style-type: none"> <li>• Data read from HI08, ESSI, SCI</li> <li>• Data write to HI08, ESSI, SCI</li> <li>• Timer</li> <li>• <math>\overline{IRQ}</math>, <math>\overline{NMI}</math> (edge trigger)</li> </ul>	$6T_C$	—	90.9	—	75.0	—	60.0	ns
		$7T_C$	—	106.1	—	87.5	—	70.0	ns
		$2T_C$	—	30.3	—	25.0	—	20.0	ns
		$3T_C$	—	45.5	—	37.5	—	30.0	ns

## Preliminary Information

## Specifications

### Reset, Stop, Mode Select, and Interrupt Timing

Table 2-7 Reset, Stop, Mode Select, and Interrupt Timing<sup>6</sup> (Continued)

No.	Characteristics	Expression	66 MHz		80 MHz		100 MHz		Unit
			Min	Max	Min	Max	Min	Max	
29	Delay from $\overline{IRQA}$ , $\overline{IRQB}$ , $\overline{IRQC}$ , $\overline{IRQD}$ , NMI assertion to external memory (DMA source) access address out valid	$4.25 \times T_C + 2.0$	66.0	—	55.1	—	44.0	—	ns
<p>Notes:</p> <ol style="list-style-type: none"> <li>When using fast interrupts and <math>\overline{IRQA}</math>, <math>\overline{IRQB}</math>, <math>\overline{IRQC}</math>, and <math>\overline{IRQD}</math> are defined as level-sensitive, timings 19 through 21 apply to prevent multiple interrupt service. To avoid these timing restrictions, the deasserted Edge-triggered mode is recommended when using fast interrupts. Long interrupts are recommended when using Level-sensitive mode.</li> <li>This timing depends on several settings: <ul style="list-style-type: none"> <li>For PLL disable, using internal oscillator (PLL Control Register (PCTL) Bit 16 = 0) and oscillator disabled during Stop (PCTL Bit 17 = 0), a stabilization delay is required to assure the oscillator is stable before executing programs. In that case, resetting the Stop delay (OMR Bit 6 = 0) will provide the proper delay. While it is possible to set OMR Bit 6 = 1, it is not recommended and these specifications do not guarantee timings for that case.</li> <li>For PLL disable, using internal oscillator (PCTL Bit 16 = 0) and oscillator enabled during Stop (PCTL Bit 17=1), no stabilization delay is required and recovery time will be minimal (OMR Bit 6 setting is ignored).</li> <li>For PLL disable, using external clock (PCTL Bit 16 = 1), no stabilization delay is required and recovery time will be defined by the PCTL Bit 17 and OMR Bit 6 settings.</li> <li>For PLL enable, if PCTL Bit 17 is 0, the PLL is shutdown during Stop. Recovering from Stop requires the PLL to get locked. The PLL lock procedure duration, PLL Lock Cycles (PLC), may be in the range of 0 to 1000 cycles. This procedure occurs in parallel with the stop delay counter, and stop recovery will end when the last of these two events occurs. The stop delay counter completes count or PLL lock procedure completion.</li> <li>PLC value for PLL disable is 0.</li> <li>The maximum value for <math>ET_C</math> is 4096 (maximum MF) divided by the desired internal frequency (i.e., for 66 MHz it is <math>4096/66 \text{ MHz} = 62 \mu\text{s}</math>). During the stabilization period, <math>T_C</math>, <math>T_H</math>, and <math>T_L</math> will not be constant, and their width may vary, so timing may vary as well.</li> </ul> </li> <li>Periodically sampled and not 100% tested</li> </ol>									

## Preliminary Information

Table 2-7 Reset, Stop, Mode Select, and Interrupt Timing<sup>6</sup> (Continued)

No.	Characteristics	Expression	66 MHz		80 MHz		100 MHz		Unit
			Min	Max	Min	Max	Min	Max	
4.	For an external clock generator, $\overline{\text{RESET}}$ duration is measured during the time in which $\overline{\text{RESET}}$ is asserted, $V_{CC}$ is valid, and the EXTAL input is active and valid.								
	For internal oscillator, $\overline{\text{RESET}}$ duration is measured during the time in which $\overline{\text{RESET}}$ is asserted and $V_{CC}$ is valid. The specified timing reflects the crystal oscillator stabilization time after power-up. This number is affected both by the specifications of the crystal and other components connected to the oscillator and reflects worst case conditions.								
	When the $V_{CC}$ is valid, but the other "required $\overline{\text{RESET}}$ duration" conditions (as specified above) have not been yet met, the device circuitry will be in an uninitialized state that can result in significant power consumption and heat-up. Designs should minimize this state to the shortest possible duration.								
5.	If PLL does not lose lock								
6.	$V_{CC} = 3.3 \text{ V} \pm 0.3 \text{ V}$ ; $T_j = -40^\circ\text{C}$ to $+100^\circ\text{C}$ , $C_L = 50 \text{ pF}$								
7.	WS = number of wait states (measured in clock cycles, number of $T_C$ )								
8.	Use expression to compute maximum value.								

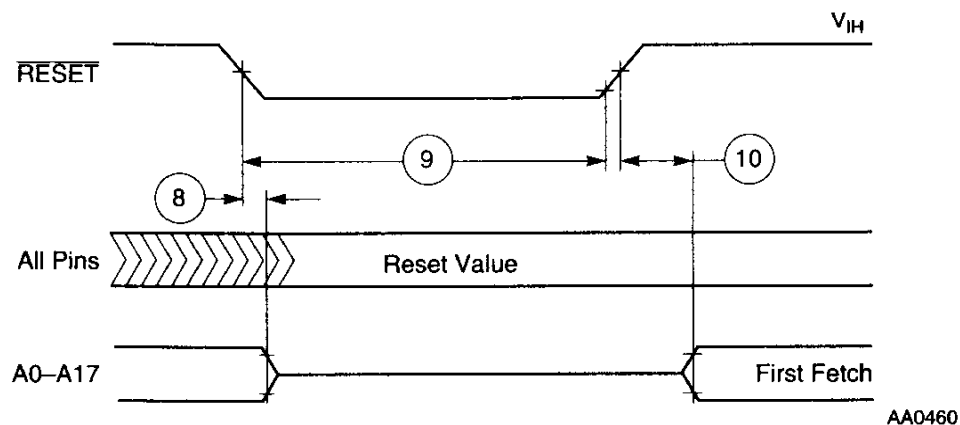

Figure 2-3 Reset Timing

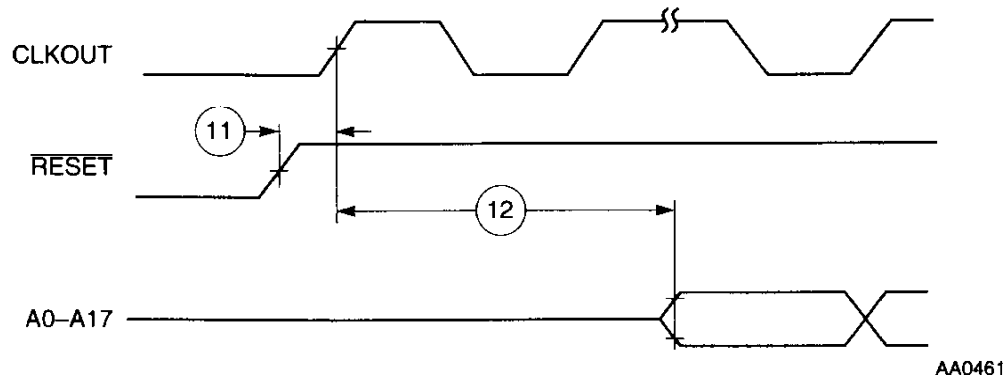
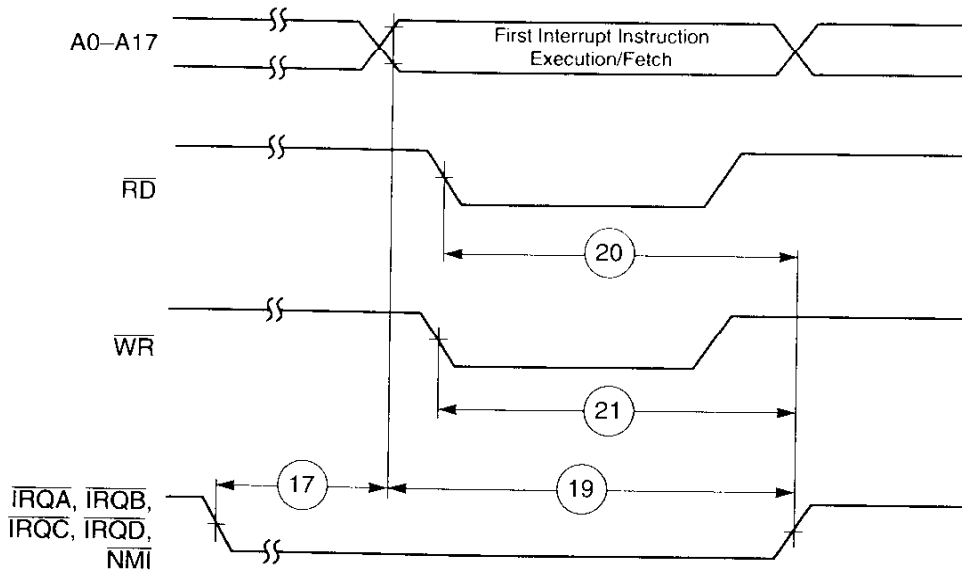

Figure 2-4 Synchronous Reset Timing

Preliminary Information

Specifications

Reset, Stop, Mode Select, and Interrupt Timing



a) First Interrupt Instruction Execution

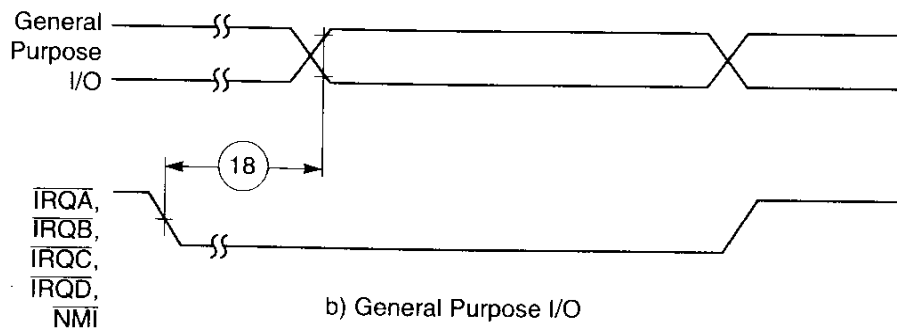

b) General Purpose I/O

AA0462

Figure 2-5 External Fast Interrupt Timing

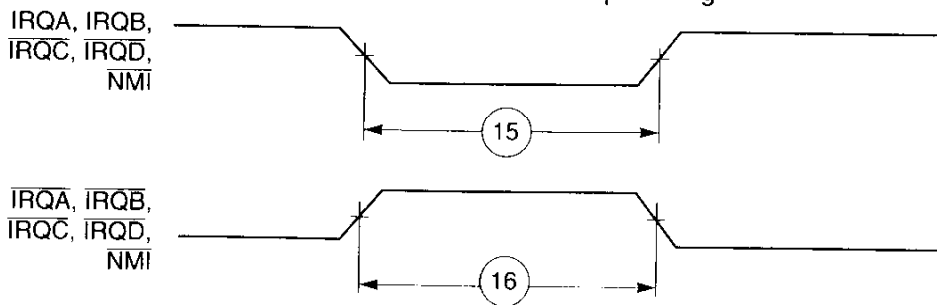

AA0463

Figure 2-6 External Interrupt Timing (Negative Edge-Triggered)

Preliminary Information



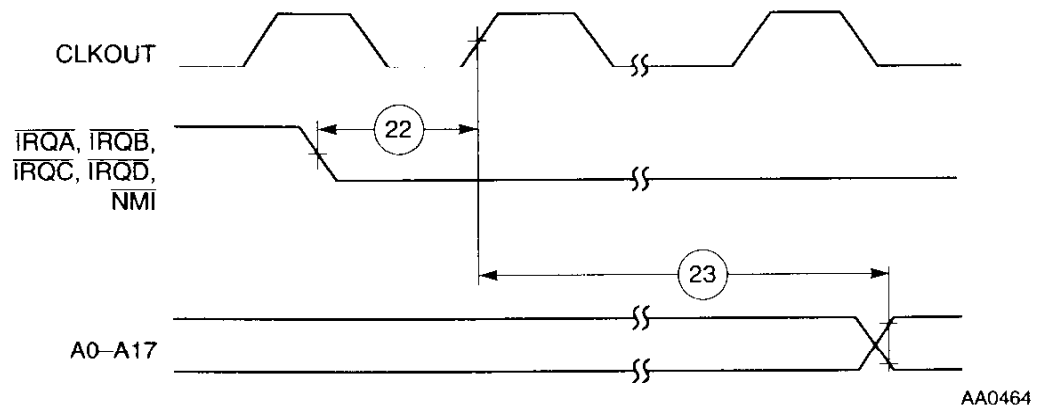

Figure 2-7 Synchronous Interrupt from Wait State Timing

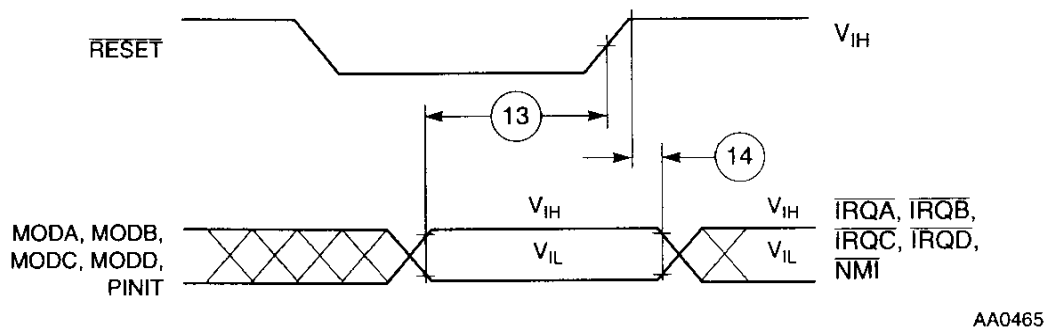

Figure 2-8 Operating Mode Select Timing

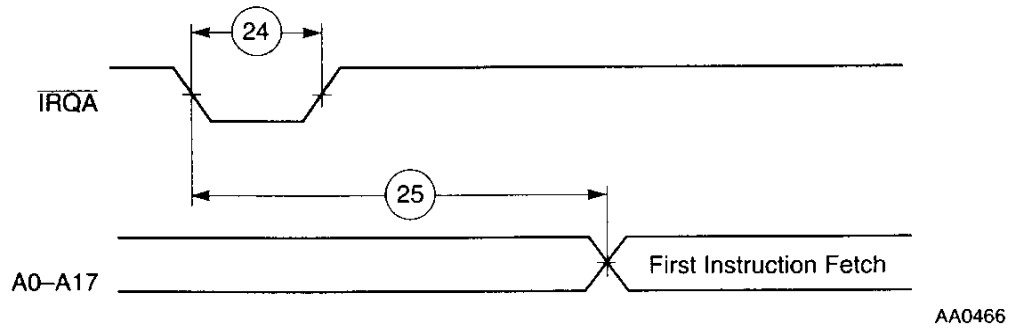
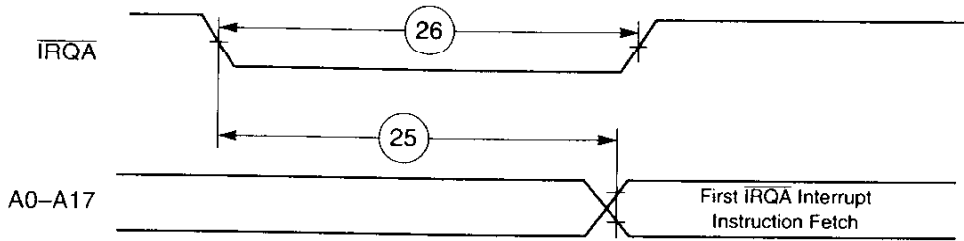

Figure 2-9 Recovery from Stop State Using  $\overline{\text{IRQA}}$

**Specifications**

**Reset, Stop, Mode Select, and Interrupt Timing**



AA0467

**Figure 2-10** Recovery from Stop State Using  $\overline{IRQA}$  Interrupt Service

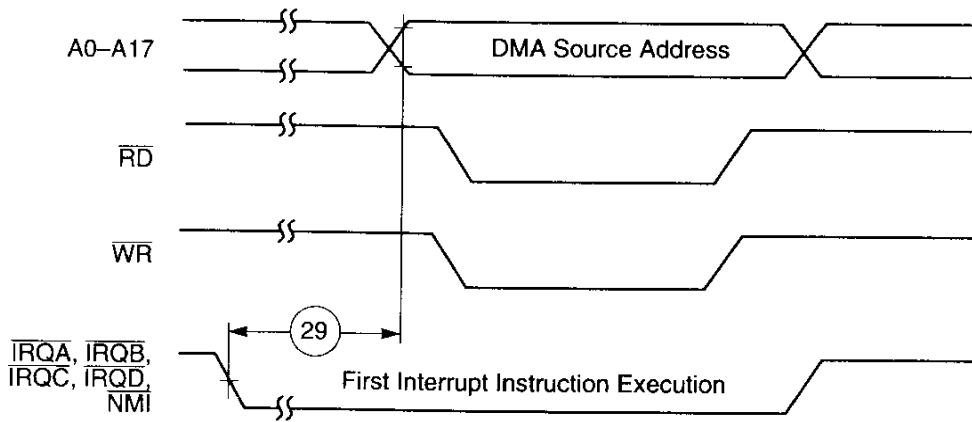

AA1104

**Figure 2-11** External Memory Access (DMA Source) Timing

**Preliminary Information**

## EXTERNAL MEMORY INTERFACE (PORT A)

## SRAM Timing

Table 2-8 SRAM Read and Write Accesses

No.	Characteristics	Symbol	Expression <sup>1</sup>	66 MHz		80 MHz		100 MHz		Unit
				Min	Max	Min	Max	Min	Max	
100	Address valid and AA assertion pulse width	$t_{RC}, t_{WC}$	$(WS + 1) \times T_C - 4.0$ [1 ≤ WS ≤ 3]	26.3	—	21.0	—	16.0	—	ns
			$(WS + 2) \times T_C - 4.0$ [4 ≤ WS ≤ 7]	86.9	—	71.0	—	56.0	—	ns
			$(WS + 3) \times T_C - 4.0$ [WS ≥ 8]	162.7	—	133.5	—	106.0	—	ns
101	Address and AA valid to $\overline{WR}$ assertion	$t_{AS}$	<b>66 MHz:</b> $0.25 \times T_C - 3.7$ [WS = 1]	0.1	—	—	—	—	—	ns
			<b>80 MHz:</b> $0.25 \times T_C - 3.0$ [WS = 1]	—	—	0.1	—	—	—	ns
			<b>100 MHz:</b> $0.25 \times T_C - 2.4$ [WS = 1]	—	—	—	—	0.1	—	ns
			<b>All frequencies:</b> $0.75 \times T_C - 4.0$ [2 ≤ WS ≤ 3]	7.4	—	5.4	—	3.5	—	ns
			$1.25 \times T_C - 4.0$ [WS ≥ 4]	14.9	—	11.6	—	8.5	—	ns
102	$\overline{WR}$ assertion pulse width	$t_{WP}$	$1.5 \times T_C - 4.5$ [WS = 1]	18.2	—	14.3	—	10.5	—	ns
			$WS \times T_C - 4.0$ [2 ≤ WS ≤ 3]	26.3	—	21.0	—	16.0	—	ns
			$(WS - 0.5) \times T_C - 4.0$ [WS ≥ 4]	49.0	—	39.8	—	31.0	—	ns

## Preliminary Information

Specifications

External Memory Interface (Port A)

Table 2-8 SRAM Read and Write Accesses (Continued)

No.	Characteristics	Symbol	Expression <sup>1</sup>	66 MHz		80 MHz		100 MHz		Unit
				Min	Max	Min	Max	Min	Max	
103	WR deassertion to address not valid	t <sub>WR</sub>	66 MHz: 0.25 × T <sub>C</sub> - 3.8 [1 ≤ WS ≤ 3]	0.1	—	—	—	—	—	ns
			80 MHz: 0.25 × T <sub>C</sub> - 3.0 [1 ≤ WS ≤ 3]	—	—	0.1	—	—	—	ns
			100 MHz: 0.25 × T <sub>C</sub> - 2.4 [1 ≤ WS ≤ 3]	—	—	—	—	0.1	—	ns
			All frequencies: 1.25 × T <sub>C</sub> - 4.0 [4 ≤ WS ≤ 7]	14.9	—	11.6	—	8.5	—	ns
			2.25 × T <sub>C</sub> - 4.0 [WS ≥ 8]	30.1	—	24.1	—	18.5	—	ns
104	Address and AA valid to input data valid	t <sub>AA</sub> , t <sub>AC</sub>	66 MHz: (WS + 0.75) × T <sub>C</sub> - 11.0 [WS ≥ 1]	—	15.5	—	—	—	—	ns
			80 MHz: (WS + 0.75) × T <sub>C</sub> - 9.5 [WS ≥ 1]	—	—	—	12.4	—	—	ns
			100 MHz: (WS + 0.75) × T <sub>C</sub> - 8.0 [WS ≥ 1]	—	—	—	—	—	9.5	ns
105	RD deassertion to input data valid	t <sub>OE</sub>	66 MHz: (WS + 0.25) × T <sub>C</sub> - 11.0 [WS ≥ 1]	—	7.9	—	—	—	—	ns
			80 MHz: (WS + 0.25) × T <sub>C</sub> - 9.5 [WS ≥ 1]	—	—	—	6.1	—	—	ns
			100 MHz: (WS + 0.25) × T <sub>C</sub> - 8.0 [WS ≥ 1]	—	—	—	—	—	4.5	ns
106	RD deassertion to data not valid (data hold time)	t <sub>OHZ</sub>		0.0	—	0.0	—	0.0	—	ns
107	Address valid to WR deassertion	t <sub>AW</sub>	(WS + 0.75) × T <sub>C</sub> - 4.0 [WS ≥ 1]	22.5	—	17.9	—	13.5	—	ns

Preliminary Information

Table 2-8 SRAM Read and Write Accesses (Continued)

No.	Characteristics	Symbol	Expression <sup>1</sup>	66 MHz		80 MHz		100 MHz		Unit
				Min	Max	Min	Max	Min	Max	
108	Data valid to $\overline{WR}$ deassertion (data setup time)	$t_{DS}$ ( $t_{DW}$ )	<b>66 MHz:</b> $(WS - 0.25) \times T_C - 3.9$ [ $WS \geq 1$ ]	7.5	—	—	—	—	—	ns
			<b>80 MHz:</b> $(WS - 0.25) \times T_C - 3.3$ [ $WS \geq 1$ ]	—	—	6.1	—	—	—	ns
			<b>100 MHz:</b> $(WS - 0.25) \times T_C - 2.75$ [ $WS \geq 1$ ]	—	—	—	—	4.8	—	ns
109	Data hold time from $\overline{WR}$ deassertion	$t_{DH}$	<b>66 MHz:</b> $0.25 \times T_C - 3.7$ [ $1 \leq WS \leq 3$ ]	0.1	—	—	—	—	—	ns
			<b>80 MHz:</b> $0.25 \times T_C - 3.0$ [ $1 \leq WS \leq 3$ ]	—	—	0.1	—	—	—	ns
			<b>100 MHz:</b> $0.25 \times T_C - 2.4$ [ $1 \leq WS \leq 3$ ]	—	—	—	—	0.1	—	ns
			<b>All frequencies:</b> $1.25 \times T_C - 3.8$ [ $4 \leq WS \leq 7$ ]	15.2	—	11.8	—	8.7	—	ns
			$2.25 \times T_C - 3.8$ [ $WS \geq 8$ ]	30.4	—	24.3	—	18.7	—	ns
110	$\overline{WR}$ assertion to data active		$0.75 \times T_C - 3.7$ [ $WS = 1$ ]	7.7	—	5.7	—	3.8	—	ns
			$0.25 \times T_C - 3.7$ [ $2 \leq WS \leq 3$ ]	0.1	—	-0.6	—	-1.2	—	ns
			$-0.25 \times T_C - 3.7$ [ $WS \geq 4$ ]	-7.5	—	-6.8	—	-6.2	—	ns
111	$\overline{WR}$ deassertion to data high impedance		$0.25 \times T_C + 0.2$ [ $1 \leq WS \leq 3$ ]	—	4.0	—	3.3	—	2.7	ns
			$1.25 \times T_C + 0.2$ [ $4 \leq WS \leq 7$ ]	—	19.1	—	15.8	—	12.7	ns
			$2.25 \times T_C + 0.2$ [ $WS \geq 8$ ]	—	34.3	—	28.3	—	22.7	ns
112	Previous $\overline{RD}$ deassertion to data active (write)		$1.25 \times T_C - 4.0$ [ $1 \leq WS \leq 3$ ]	14.9	—	11.6	—	8.5	—	ns
			$2.25 \times T_C - 4.0$ [ $4 \leq WS \leq 7$ ]	30.1	—	24.1	—	18.5	—	ns
			$3.25 \times T_C - 4.0$ [ $WS \geq 8$ ]	45.2	—	36.6	—	28.5	—	ns

## Preliminary Information

**Specifications**

**External Memory Interface (Port A)**

**Table 2-8 SRAM Read and Write Accesses (Continued)**

No.	Characteristics	Symbol	Expression <sup>1</sup>	66 MHz		80 MHz		100 MHz		Unit
				Min	Max	Min	Max	Min	Max	
113	RD deassertion time		$0.75 \times T_C - 4.0$ [1 ≤ WS ≤ 3]	7.4	—	5.4	—	3.5	—	ns
			$1.75 \times T_C - 4.0$ [4 ≤ WS ≤ 7]	22.5	—	17.9	—	13.5	—	ns
			$2.75 \times T_C - 4.0$ [WS ≥ 8]	37.7	—	30.4	—	23.5	—	ns
114	WR deassertion time		$0.5 \times T_C - 3.5$ [WS = 1]	4.1	—	2.8	—	1.5	—	ns
			$T_C - 3.5$ [2 ≤ WS ≤ 3]	11.7	—	9.0	—	6.5	—	ns
			$2.5 \times T_C - 3.5$ [4 ≤ WS ≤ 7]	34.4	—	27.8	—	21.5	—	ns
			$3.5 \times T_C - 3.5$ [WS ≥ 8]	49.5	—	40.3	—	31.5	—	ns
115	Address valid to RD assertion		$0.5 \times T_C - 4$	3.5	—	2.3	—	1.0	—	ns
116	RD assertion pulse width		$(WS + 0.25) \times T_C - 3.8$	15.1	—	11.8	—	8.7	—	ns
117	RD deassertion to address not valid		$0.25 \times T_C - 3.0$ [1 ≤ WS ≤ 3]	0.7	—	0.1	—	0.0	—	ns
			$1.25 \times T_C - 3.0$ [4 ≤ WS ≤ 7]	15.9	—	12.6	—	9.5	—	ns
			$2.25 \times T_C - 3.0$ [WS ≥ 8]	31.0	—	25.1	—	19.5	—	ns

Notes: 1. WS is the number of wait states specified in the BCR.  
 2.  $V_{CC} = 3.3 \text{ V} \pm 0.3 \text{ V}$ ;  $T_J = -40^\circ\text{C}$  to  $+100^\circ\text{C}$ ,  $C_L = 50 \text{ pF}$

**Preliminary Information**

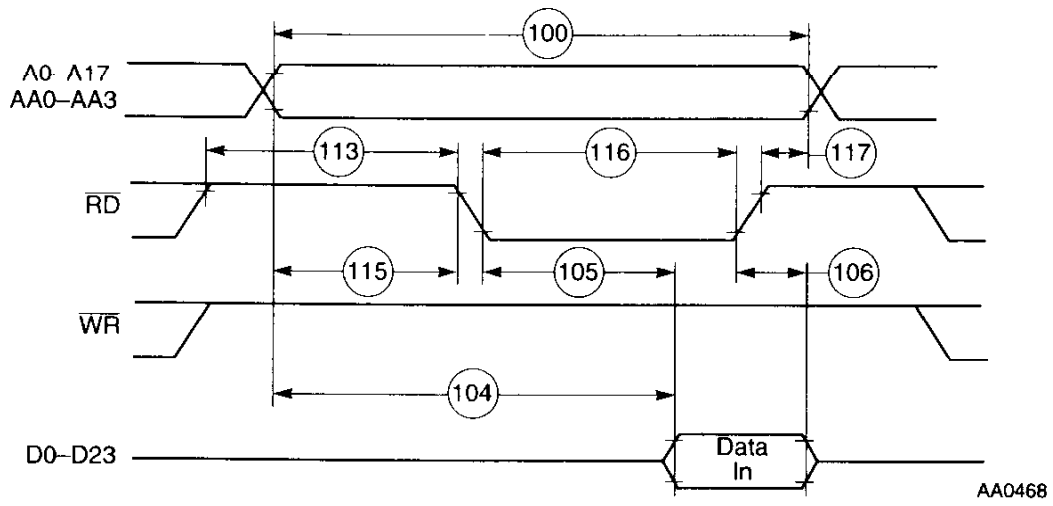

Figure 2-12 SRAM Read Access

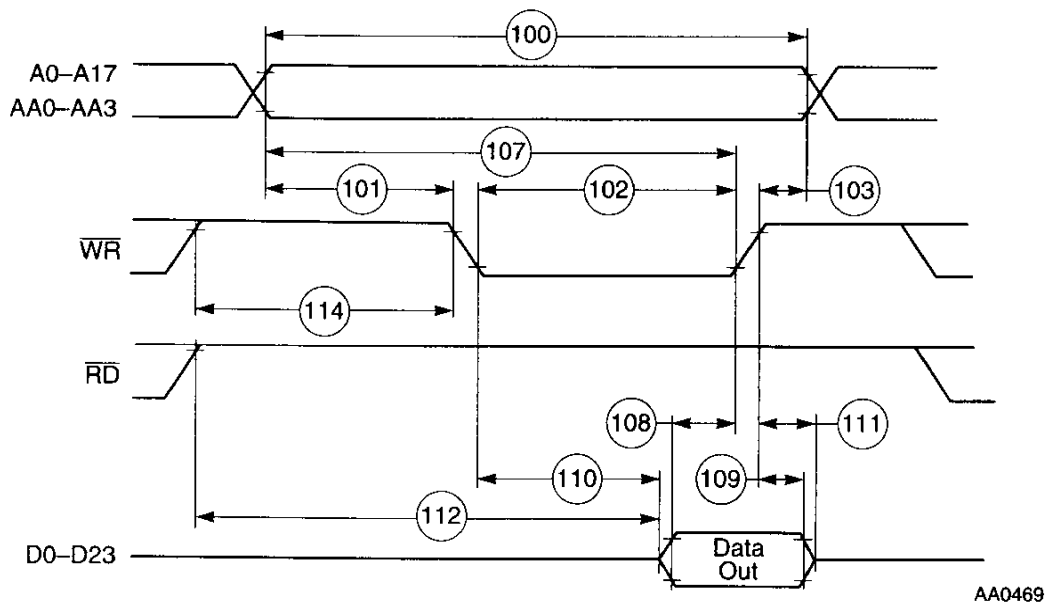
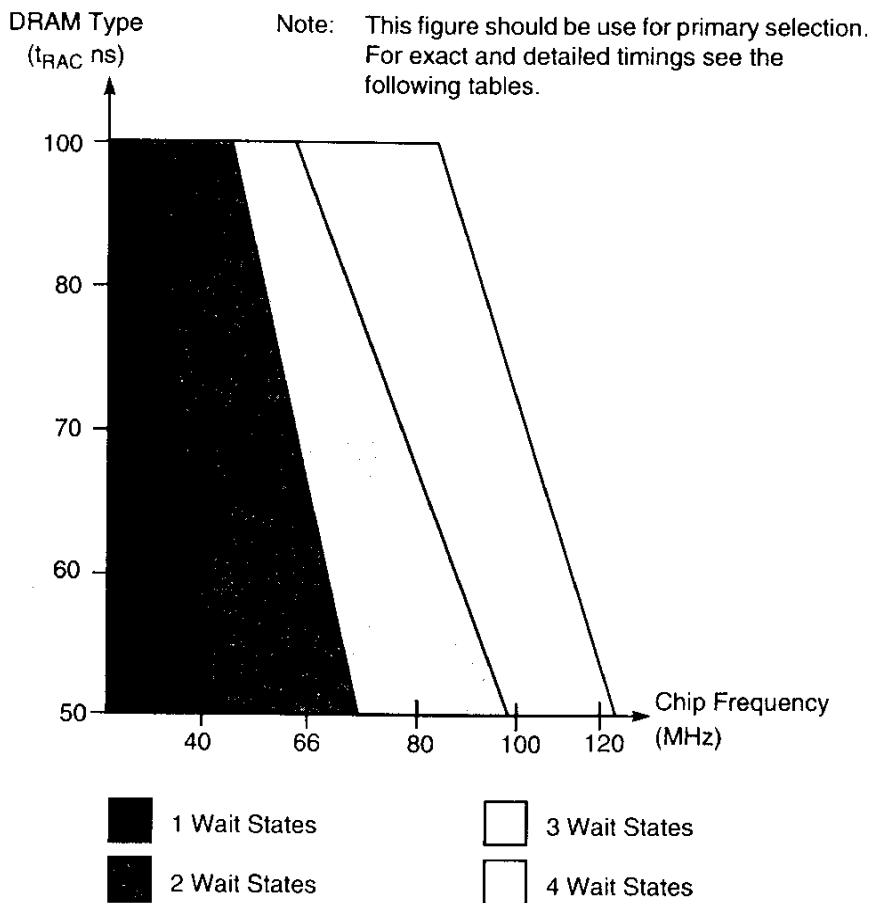

Figure 2-13 SRAM Write Access

Preliminary Information

## DRAM Timing

The selection guides provided in **Figure 2-14** and **Figure 2-17** on page 2-37 should be used for primary selection only. Final selection should be based on the timing provided in the following tables. As an example, the selection guide suggests that 4 wait states must be used for 100 MHz operation when using Page Mode DRAM. However, by using the information in the appropriate table, a designer may choose to evaluate whether fewer wait states might be used by determining which timing prevents operation at 100 MHz, running the chip at a slightly lower frequency (e.g., 95 MHz), using faster DRAM (if it becomes available), and control factors such as capacitive and resistive load to improve overall system performance.



**Figure 2-14** DRAM Page Mode Wait States Selection Guide



Table 2-9 DRAM Page Mode Timings, One Wait State (Low-Power Applications)<sup>1, 2, 3</sup>

No.	Characteristics	Symbol	Expression	20 MHz <sup>6</sup>		30 MHz <sup>6</sup>		Unit
				Min	Max	Min	Max	
131	Page mode cycle time	$t_{PC}$	$1.25 \times T_C$	62.5	—	41.7	—	ns
132	$\overline{CAS}$ assertion to data valid (read)	$t_{CAC}$	$T_C - 7.5$	—	42.5	—	25.8	ns
133	Column address valid to data valid (read)	$t_{AA}$	$1.5 \times T_C - 7.5$	—	67.5	—	42.5	ns
134	$\overline{CAS}$ deassertion to data not valid (read hold time)	$t_{OFF}$		0.0	—	0.0	—	ns
135	Last $\overline{CAS}$ assertion to $\overline{RAS}$ deassertion	$t_{RSH}$	$0.75 \times T_C - 4.0$	33.5	—	21.0	—	ns
136	Previous $\overline{CAS}$ deassertion to $\overline{RAS}$ deassertion	$t_{RHCP}$	$2 \times T_C - 4.0$	96.0	—	62.7	—	ns
137	$\overline{CAS}$ assertion pulse width	$t_{CAS}$	$0.75 \times T_C - 4.0$	33.5	—	21.0	—	ns
138	Last $\overline{CAS}$ deassertion to $\overline{RAS}$ deassertion <sup>4</sup> <ul style="list-style-type: none"> <li>• BRW[1:0] = 00</li> <li>• BRW[1:0] = 01</li> <li>• BRW[1:0] = 10</li> <li>• BRW[1:0] = 11</li> </ul>	$t_{CRP}$	$1.75 \times T_C - 6.0$ $3.25 \times T_C - 6.0$ $4.25 \times T_C - 6.0$ $6.25 \times T_C - 6.0$	81.5 156.5 206.5 306.5	— — — —	52.3 102.2 135.5 202.1	— — — —	ns ns ns ns
139	$\overline{CAS}$ deassertion pulse width	$t_{CP}$	$0.5 \times T_C - 4.0$	21.0	—	12.7	—	ns
140	Column address valid to $\overline{CAS}$ assertion	$t_{ASC}$	$0.5 \times T_C - 4.0$	21.0	—	12.7	—	ns
141	$\overline{CAS}$ assertion to column address not valid	$t_{CAH}$	$0.75 \times T_C - 4.0$	33.5	—	21.0	—	ns
142	Last column address valid to $\overline{RAS}$ deassertion	$t_{RAL}$	$2 \times T_C - 4.0$	96.0	—	62.7	—	ns
143	$\overline{WR}$ deassertion to $\overline{CAS}$ assertion	$t_{RCS}$	$0.75 \times T_C - 3.8$	33.7	—	21.2	—	ns
144	$\overline{CAS}$ deassertion to $\overline{WR}$ assertion	$t_{RCH}$	$0.25 \times T_C - 3.7$	8.8	—	4.6	—	ns
145	$\overline{CAS}$ assertion to $\overline{WR}$ deassertion	$t_{WCH}$	$0.5 \times T_C - 4.2$	20.8	—	12.5	—	ns
146	$\overline{WR}$ assertion pulse width	$t_{WP}$	$1.5 \times T_C - 4.5$	70.5	—	45.5	—	ns
147	Last $\overline{WR}$ assertion to $\overline{RAS}$ deassertion	$t_{RWL}$	$1.75 \times T_C - 4.3$	83.2	—	54.0	—	ns

## Preliminary Information

## Specifications

### External Memory Interface (Port A)

Table 2-9 DRAM Page Mode Timings, One Wait State (Low-Power Applications)<sup>1, 2, 3</sup>

No.	Characteristics	Symbol	Expression	20 MHz <sup>6</sup>		30 MHz <sup>6</sup>		Unit
				Min	Max	Min	Max	
148	$\overline{WR}$ assertion to $\overline{CAS}$ deassertion	$t_{CWL}$	$1.75 \times T_C - 4.3$	83.2	—	54.0	—	ns
149	Data valid to $\overline{CAS}$ assertion (Write)	$t_{DS}$	$0.25 \times T_C - 4.0$	8.5	—	4.3	—	ns
150	$\overline{CAS}$ assertion to data not valid (write)	$t_{DH}$	$0.75 \times T_C - 4.0$	33.5	—	21.0	—	ns
151	$\overline{WR}$ assertion to $\overline{CAS}$ assertion	$t_{WCS}$	$T_C - 4.3$	45.7	—	29.0	—	ns
152	Last $\overline{RD}$ assertion to $\overline{RAS}$ deassertion	$t_{ROH}$	$1.5 \times T_C - 4.0$	71.0	—	46.0	—	ns
153	$\overline{RD}$ assertion to data valid	$t_{GA}$	$T_C - 7.5$	—	42.5	—	25.8	ns
154	$\overline{RD}$ deassertion to data not valid <sup>5</sup>	$t_{GZ}$		0.0	—	0.0	—	ns
155	$\overline{WR}$ assertion to data active		$0.75 \times T_C - 0.3$	37.2	—	24.7	—	ns
156	$\overline{WR}$ deassertion to data high impedance		$0.25 \times T_C$	—	12.5	—	8.3	ns

Notes:

1. The number of wait states for Page mode access is specified in the DCR.
2. The refresh period is specified in the DCR.
3. All the timings are calculated for the worst case. Some of the timings are better for specific cases (e.g.,  $t_{PC}$  equals  $2 \times T_C$  for read-after-read or write-after-write sequences).
4. BRW[1:0] (DRAM control register bits) defines the number of wait states that should be inserted in each DRAM out-of-page access.
5.  $\overline{RD}$  deassertion will always occur after  $\overline{CAS}$  deassertion; therefore, the restricted timing is  $t_{OFF}$  and not  $t_{GZ}$ .
6. Reduced DSP clock speed allows use of Page Mode DRAM with one wait state (see **Figure 2-14**).

### Preliminary Information

Table 2-10 DRAM Page Mode Timings, Two Wait States<sup>1, 2, 3, 7</sup>

No.	Characteristics	Symbol	Expression	66 MHz		80 MHz		Unit
				Min	Max	Min	Max	
131	Page mode cycle time	$t_{PC}$	$2.75 \times T_C$	41.7	—	34.4	—	ns
132	$\overline{CAS}$ assertion to data valid (read)	$t_{CAC}$	66 MHz:	—	15.2	—	—	ns
			80 MHz:	—	—	—	12.3	ns
133	Column address valid to data valid (read)	$t_{AA}$	66 MHz:	—	30.4	—	—	ns
			80 MHz:	—	—	—	24.8	ns
134	$\overline{CAS}$ deassertion to data not valid (read hold time)	$t_{OFF}$		0.0	—	0.0	—	ns
135	Last $\overline{CAS}$ assertion to $\overline{RAS}$ deassertion	$t_{RSH}$	$1.75 \times T_C - 4.0$	22.5	—	17.9	—	ns
136	Previous $\overline{CAS}$ deassertion to $\overline{RAS}$ deassertion	$t_{RHCP}$	$3.25 \times T_C - 4.0$	45.2	—	36.6	—	ns
137	$\overline{CAS}$ assertion pulse width	$t_{CAS}$	$1.5 \times T_C - 4.0$	18.7	—	14.8	—	ns
138	Last $\overline{CAS}$ deassertion to $\overline{RAS}$ deassertion <sup>5</sup> • BRW[1:0] = 00 • BRW[1:0] = 01 • BRW[1:0] = 10 • BRW[1:0] = 11	$t_{CRP}$	$2.0 \times T_C - 6.0$	24.4	—	19.0	—	ns
			$3.5 \times T_C - 6.0$	47.2	—	37.8	—	ns
			$4.5 \times T_C - 6.0$	62.4	—	50.3	—	ns
			$6.5 \times T_C - 6.0$	92.8	—	75.3	—	ns
139	$\overline{CAS}$ deassertion pulse width	$t_{CP}$	$1.25 \times T_C - 4.0$	14.9	—	11.6	—	ns
140	Column address valid to $\overline{CAS}$ assertion	$t_{ASC}$	$T_C - 4.0$	11.2	—	8.5	—	ns
141	$\overline{CAS}$ assertion to column address not valid	$t_{CAH}$	$1.75 \times T_C - 4.0$	22.5	—	17.9	—	ns
142	Last column address valid to $\overline{RAS}$ deassertion	$t_{RAL}$	$3 \times T_C - 4.0$	41.5	—	33.5	—	ns
143	$\overline{WR}$ deassertion to $\overline{CAS}$ assertion	$t_{RCS}$	$1.25 \times T_C - 3.8$	15.1	—	11.8	—	ns
144	$\overline{CAS}$ deassertion to $\overline{WR}$ assertion	$t_{RCH}$	$0.5 \times T_C - 3.7$	3.9	—	2.6	—	ns
145	$\overline{CAS}$ assertion to $\overline{WR}$ deassertion	$t_{WCH}$	$1.5 \times T_C - 4.2$	18.5	—	14.6	—	ns
146	$\overline{WR}$ assertion pulse width	$t_{WP}$	$2.5 \times T_C - 4.5$	33.4	—	26.8	—	ns

## Preliminary Information

## Specifications

### External Memory Interface (Port A)

Table 2-10 DRAM Page Mode Timings, Two Wait States<sup>1,2,3,7</sup> (Continued)

No.	Characteristics	Symbol	Expression	66 MHz		80 MHz		Unit
				Min	Max	Min	Max	
147	Last $\overline{WR}$ assertion to $\overline{RAS}$ deassertion	$t_{RWL}$	$2.75 \times T_C - 4.3$	37.4	—	30.1	—	ns
148	$\overline{WR}$ assertion to $\overline{CAS}$ deassertion	$t_{CWL}$	$2.5 \times T_C - 4.3$	33.6	—	27.0	—	ns
149	Data valid to $\overline{CAS}$ assertion (write)	$t_{DS}$	66 MHz:	0.1	—	—	—	ns
			80 MHz:	—	—	0.1	—	ns
150	$\overline{CAS}$ assertion to data not valid (write)	$t_{DH}$	$1.75 \times T_C - 4.0$	22.5	—	17.9	—	ns
151	$\overline{WR}$ assertion to $\overline{CAS}$ assertion	$t_{WCS}$	$T_C - 4.3$	10.9	—	8.2	—	ns
152	Last $\overline{RD}$ assertion to $\overline{RAS}$ deassertion	$t_{ROH}$	$2.5 \times T_C - 4.0$	33.9	—	27.3	—	ns
153	$\overline{RD}$ assertion to data valid	$t_{GA}$	66 MHz:	—	19.0	—	—	ns
			80 MHz:	—	—	—	15.4	ns
154	$\overline{RD}$ deassertion to data not valid <sup>6</sup>	$t_{GZ}$		0.0	—	0.0	—	ns
155	$\overline{WR}$ assertion to data active		$0.75 \times T_C - 0.3$	11.1	—	9.1	—	ns
156	$\overline{WR}$ deassertion to data high impedance		$0.25 \times T_C$	—	3.8	—	3.1	ns

Notes:

1. The number of wait states for Page mode access is specified in the DCR.
2. The refresh period is specified in the DCR.
3. The asynchronous delays specified in the expressions are valid for DSP56302A.
4. All the timings are calculated for the worst case. Some of the timings are better for specific cases (e.g.,  $t_{PC}$  equals  $3 \times T_C$  for read-after-read or write-after-write sequences).
5. BRW[1:0] (DRAM Control Register bits) defines the number of wait states that should be inserted in each DRAM out-of-page access.
6.  $\overline{RD}$  deassertion will always occur after  $\overline{CAS}$  deassertion; therefore, the restricted timing is  $t_{OFF}$  and not  $t_{GZ}$ .
7. There are no DRAMs fast enough to meet the specifications for two wait state Page mode @ 100MHz (see Figure 2-14).

### Preliminary Information

Table 2-11 DRAM Page Mode Timings, Three Wait States<sup>1, 2, 3</sup>

No.	Characteristics	Symbol	Expression	66 MHz		80 MHz		100 MHz		Unit
				Min	Max	Min	Max	Min	Max	
131	Page mode cycle time	$t_{PC}$	$3.5 \times T_C$	53.0	—	43.8	—	35.0	—	ns
132	$\overline{CAS}$ assertion to data valid (read)	$t_{CAC}$	66 MHz: $2 \times T_C - 7.5$	—	22.8	—	—	—	—	ns
			80 MHz: $2 \times T_C - 6.5$	—	—	—	18.5	—	—	ns
			100 MHz: $2 \times T_C - 5.7$	—	—	—	—	—	14.3	ns
133	Column address valid to data valid (read)	$t_{AA}$	66 MHz: $3 \times T_C - 7.5$	—	37.9	—	—	—	—	ns
			80 MHz: $3 \times T_C - 6.5$	—	—	—	31.0	—	—	ns
			100 MHz: $3 \times T_C - 5.7$	—	—	—	—	—	24.3	ns
134	$\overline{CAS}$ deassertion to data not valid (read hold time)	$t_{OFF}$		0.0	—	0.0	—	0.0	—	ns
135	Last $\overline{CAS}$ assertion to $\overline{RAS}$ deassertion	$t_{RSH}$	$2.5 \times T_C - 4.0$	33.9	—	27.3	—	21.0	—	ns
136	Previous $\overline{CAS}$ deassertion to $\overline{RAS}$ deassertion	$t_{RHCP}$	$4.5 \times T_C - 4.0$	64.2	—	52.3	—	41.0	—	ns
137	$\overline{CAS}$ assertion pulse width	$t_{CAS}$	$2 \times T_C - 4.0$	26.3	—	21.0	—	16.0	—	ns
138	Last $\overline{CAS}$ deassertion to $\overline{RAS}$ deassertion <sup>5</sup> • BRW[1:0] = 00 • BRW[1:0] = 01 • BRW[1:0] = 10 • BRW[1:0] = 11	$t_{CRP}$	$2.25 \times T_C - 6.0$	28.2	—	22.2	—	16.5	—	ns
			$3.75 \times T_C - 6.0$	51.0	—	40.9	—	31.5	—	ns
			$4.75 \times T_C - 6.0$	66.2	—	53.4	—	41.5	—	ns
			$6.75 \times T_C - 6.0$	96.6	—	78.4	—	61.5	—	ns
139	$\overline{CAS}$ deassertion pulse width	$t_{CP}$	$1.5 \times T_C - 4.0$	18.7	—	14.8	—	11.0	—	ns
140	Column address valid to $\overline{CAS}$ assertion	$t_{ASC}$	$T_C - 4.0$	11.2	—	8.5	—	6.0	—	ns
141	$\overline{CAS}$ assertion to column address not valid	$t_{CAH}$	$2.5 \times T_C - 4.0$	33.9	—	27.3	—	21.0	—	ns
142	Last column address valid to $\overline{RAS}$ deassertion	$t_{RAL}$	$4 \times T_C - 4.0$	56.6	—	46.0	—	36.0	—	ns
143	$\overline{WR}$ deassertion to $\overline{CAS}$ assertion	$t_{RCS}$	$1.25 \times T_C - 3.8$	15.1	—	11.8	—	8.7	—	ns
144	$\overline{CAS}$ deassertion to $\overline{WR}$ assertion	$t_{RCH}$	$0.75 \times T_C - 3.7$	7.7	—	5.7	—	3.8	—	ns

## Preliminary Information

## Specifications

### External Memory Interface (Port A)

Table 2-11 DRAM Page Mode Timings, Three Wait States<sup>1, 2, 3</sup> (Continued)

No.	Characteristics	Symbol	Expression	66 MHz		80 MHz		100 MHz		Unit
				Min	Max	Min	Max	Min	Max	
145	CAS assertion to $\overline{WR}$ deassertion	$t_{WCH}$	$2.25 \times T_C - 4.2$	29.9	—	23.9	—	18.3	—	ns
146	$\overline{WR}$ assertion pulse width	$t_{WP}$	$3.5 \times T_C - 4.5$	48.5	—	39.3	—	30.5	—	ns
147	Last $\overline{WR}$ assertion to $\overline{RAS}$ deassertion	$t_{RWL}$	$3.75 \times T_C - 4.3$	52.5	—	42.6	—	33.2	—	ns
148	$\overline{WR}$ assertion to $\overline{CAS}$ deassertion	$t_{CWL}$	$3.25 \times T_C - 4.3$	44.9	—	36.3	—	28.2	—	ns
149	Data valid to $\overline{CAS}$ assertion (write)	$t_{DS}$	$0.5 \times T_C - 4.0$	3.6	—	2.3	—	1.0	—	ns
150	CAS assertion to data not valid (write)	$t_{DH}$	$2.5 \times T_C - 4.0$	33.9	—	27.3	—	21.0	—	ns
151	$\overline{WR}$ assertion to $\overline{CAS}$ assertion	$t_{WCS}$	$1.25 \times T_C - 4.3$	14.6	—	11.3	—	8.2	—	ns
152	Last $\overline{RD}$ assertion to $\overline{RAS}$ deassertion	$t_{ROH}$	$3.5 \times T_C - 4.0$	49.0	—	39.8	—	31.0	—	ns
153	$\overline{RD}$ assertion to data valid	$t_{GA}$	66 MHz: $2.5 \times T_C - 7.5$	—	30.4	—	—	—	—	ns
			80 MHz: $2.5 \times T_C - 6.5$	—	—	—	24.8	—	—	ns
			100 MHz: $2.5 \times T_C - 5.7$	—	—	—	—	—	19.3	ns
154	$\overline{RD}$ deassertion to data not valid <sup>6</sup>	$t_{GZ}$		0.0	—	0.0	—	0.0	—	ns
155	$\overline{WR}$ assertion to data active		$0.75 \times T_C - 0.3$	11.1	—	9.1	—	7.2	—	ns
156	$\overline{WR}$ deassertion to data high impedance		$0.25 \times T_C$	—	3.8	—	3.1	—	2.5	ns

Notes:

- The number of wait states for Page mode access is specified in the DCR.
- The refresh period is specified in the DCR.
- The asynchronous delays specified in the expressions are valid for DSP56302A.
- All the timings are calculated for the worst case. Some of the timings are better for specific cases (e.g.,  $t_{PC}$  equals  $4 \times T_C$  for read-after-read or write-after-write sequences).
- BRW[1:0] (DRAM control register bits) defines the number of wait states that should be inserted in each DRAM out-of-page-access.
- $\overline{RD}$  deassertion will always occur after  $\overline{CAS}$  deassertion; therefore, the restricted timing is  $t_{OFF}$  and not  $t_{GZ}$ .

### Preliminary Information

Table 2-12 DRAM Page Mode Timings, Four Wait States<sup>1, 2, 3</sup>

No.	Characteristics	Symbol	Expression	66 MHz		80 MHz		100 MHz		Unit	
				Min	Max	Min	Max	Min	Max		
131	Page mode cycle time	$t_{PC}$	$4.5 \times T_C$	68.2	—	56.3	—	45.0	—	ns	
132	$\overline{CAS}$ assertion to data valid (read)	$t_{CAC}$	66 MHz:	—	34.2	—	—	—	—	ns	
			$2.75 \times T_C - 7.5$	—	—	—	27.9	—	—	ns	
			80 MHz:	—	—	—	—	—	21.8	ns	
			$2.75 \times T_C - 6.5$	—	—	—	—	—	ns		
			100 MHz:	—	—	—	—	—	21.8	ns	
			$2.75 \times T_C - 5.7$	—	—	—	—	—	21.8	ns	
133	Column address valid to data valid (read)	$t_{AA}$	66 MHz:	—	49.3	—	—	—	—	ns	
			$3.75 \times T_C - 7.5$	—	—	—	40.4	—	—	ns	
			80 MHz:	—	—	—	—	—	31.8	ns	
			$3.75 \times T_C - 6.5$	—	—	—	—	—	ns		
			100 MHz:	—	—	—	—	—	31.8	ns	
			$3.75 \times T_C - 5.7$	—	—	—	—	—	31.8	ns	
134	$\overline{CAS}$ deassertion to data not valid (read hold time)	$t_{OFF}$		0.0	—	0.0	—	0.0	—	ns	
135	Last $\overline{CAS}$ assertion to $\overline{RAS}$ deassertion	$t_{RSH}$	$3.5 \times T_C - 4.0$	49.0	—	39.8	—	31.0	—	ns	
136	Previous $\overline{CAS}$ deassertion to $\overline{RAS}$ deassertion	$t_{RHCP}$	$6 \times T_C - 4.0$	86.9	—	71.0	—	56.0	—	ns	
137	$\overline{CAS}$ assertion pulse width	$t_{CAS}$	$2.5 \times T_C - 4.0$	33.9	—	27.3	—	21.0	—	ns	
138	Last $\overline{CAS}$ deassertion to $\overline{RAS}$ deassertion <sup>5</sup>	$t_{CRP}$									
			• BRW[1:0] = 00	$2.75 \times T_C - 6.0$	35.8	—	28.4	—	21.5	—	ns
			• BRW[1:0] = 01	$4.25 \times T_C - 6.0$	58.6	—	47.2	—	36.5	—	ns
			• BRW[1:0] = 10	$5.25 \times T_C - 6.0$	73.8	—	59.7	—	46.5	—	ns
	• BRW[1:0] = 11	$6.25 \times T_C - 6.0$	89.0	—	72.2	—	56.5	—	ns		
139	$\overline{CAS}$ deassertion pulse width	$t_{CP}$	$2 \times T_C - 4.0$	26.3	—	21.0	—	16.0	—	ns	
140	Column address valid to $\overline{CAS}$ assertion	$t_{ASC}$	$T_C - 4.0$	11.2	—	8.5	—	6.0	—	ns	
141	$\overline{CAS}$ assertion to column address not valid	$t_{CAH}$	$3.5 \times T_C - 4.0$	49.0	—	39.8	—	31.0	—	ns	
142	Last column address valid to $\overline{RAS}$ deassertion	$t_{RAL}$	$5 \times T_C - 4.0$	71.8	—	58.5	—	46.0	—	ns	
143	$\overline{WR}$ deassertion to $\overline{CAS}$ assertion	$t_{RCS}$	$1.25 \times T_C - 3.8$	15.1	—	11.8	—	8.7	—	ns	
144	$\overline{CAS}$ deassertion to $\overline{WR}$ assertion	$t_{RCH}$	$1.25 \times T_C - 3.7$	15.2	—	11.9	—	8.8	—	ns	

## Preliminary Information

Specifications

External Memory Interface (Port A)

Table 2-12 DRAM Page Mode Timings, Four Wait States<sup>1,2,3</sup> (Continued)

No.	Characteristics	Symbol	Expression	66 MHz		80 MHz		100 MHz		Unit
				Min	Max	Min	Max	Min	Max	
145	$\overline{\text{CAS}}$ assertion to $\overline{\text{WR}}$ deassertion	$t_{\text{WCH}}$	$3.25 \times T_{\text{C}} - 4.2$	45.0	—	36.4	—	28.3	—	ns
146	$\overline{\text{WR}}$ assertion pulse width	$t_{\text{WP}}$	$4.5 \times T_{\text{C}} - 4.5$	63.7	—	51.8	—	40.5	—	ns
147	Last $\overline{\text{WR}}$ assertion to $\overline{\text{RAS}}$ deassertion	$t_{\text{RWL}}$	$4.75 \times T_{\text{C}} - 4.3$	67.7	—	55.1	—	43.2	—	ns
148	$\overline{\text{WR}}$ assertion to $\overline{\text{CAS}}$ deassertion	$t_{\text{CWL}}$	$3.75 \times T_{\text{C}} - 4.3$	52.5	—	42.6	—	33.2	—	ns
149	Data valid to $\overline{\text{CAS}}$ assertion (write)	$t_{\text{DS}}$	$0.5 \times T_{\text{C}} - 4.0$	3.6	—	2.3	—	1.0	—	ns
150	$\overline{\text{CAS}}$ assertion to data not valid (write)	$t_{\text{DH}}$	$3.5 \times T_{\text{C}} - 4.0$	49.0	—	39.8	—	31.0	—	ns
151	$\overline{\text{WR}}$ assertion to $\overline{\text{CAS}}$ assertion	$t_{\text{WCS}}$	$1.25 \times T_{\text{C}} - 4.3$	14.6	—	11.3	—	8.2	—	ns
152	Last $\overline{\text{RD}}$ assertion to $\overline{\text{RAS}}$ deassertion	$t_{\text{ROH}}$	$4.5 \times T_{\text{C}} - 4.0$	64.2	—	52.3	—	41.0	—	ns
153	$\overline{\text{RD}}$ assertion to data valid	$t_{\text{GA}}$	<b>66 MHz:</b> $3.25 \times T_{\text{C}} - 7.5$ <b>80 MHz:</b> $3.25 \times T_{\text{C}} - 6.5$ <b>100 MHz:</b> $3.25 \times T_{\text{C}} - 5.7$	—	41.7	—	—	—	—	ns
				—	—	—	34.1	—	—	ns
				—	—	—	—	—	26.8	ns
154	$\overline{\text{RD}}$ deassertion to data not valid <sup>6</sup>	$t_{\text{GZ}}$		0.0	—	0.0	—	0.0	—	ns
155	$\overline{\text{WR}}$ assertion to data active		$0.75 \times T_{\text{C}} - 0.3$	11.1	—	9.1	—	7.2	—	ns
156	$\overline{\text{WR}}$ deassertion to data high impedance		$0.25 \times T_{\text{C}}$	—	3.8	—	3.1	—	2.5	ns

- Notes:
1. The number of wait states for Page mode access is specified in the DCR.
  2. The refresh period is specified in the DCR.
  3. The asynchronous delays specified in the expressions are valid for DSP56302A.
  4. All the timings are calculated for the worst case. Some of the timings are better for specific cases (e.g.,  $t_{\text{PC}}$  equals  $3 \times T_{\text{C}}$  for read-after-read or write-after-write sequences).
  5. BRW[1:0] (DRAM control register bits) defines the number of wait states that should be inserted in each DRAM out-of-page access.
  6.  $\overline{\text{RD}}$  deassertion will always occur after  $\overline{\text{CAS}}$  deassertion; therefore, the restricted timing is  $t_{\text{OFF}}$  and not  $t_{\text{GZ}}$ .

Preliminary Information



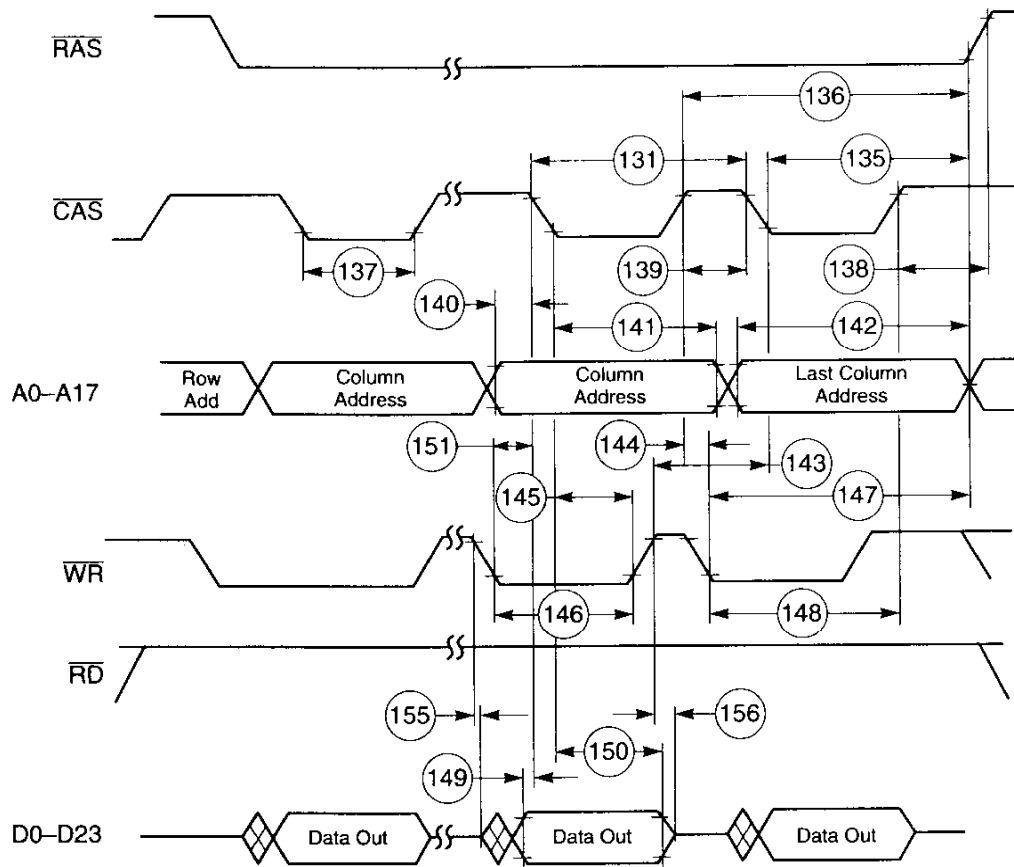

AA0473

Figure 2-15 DRAM Page Mode Write Accesses

Specifications

External Memory Interface (Port A)

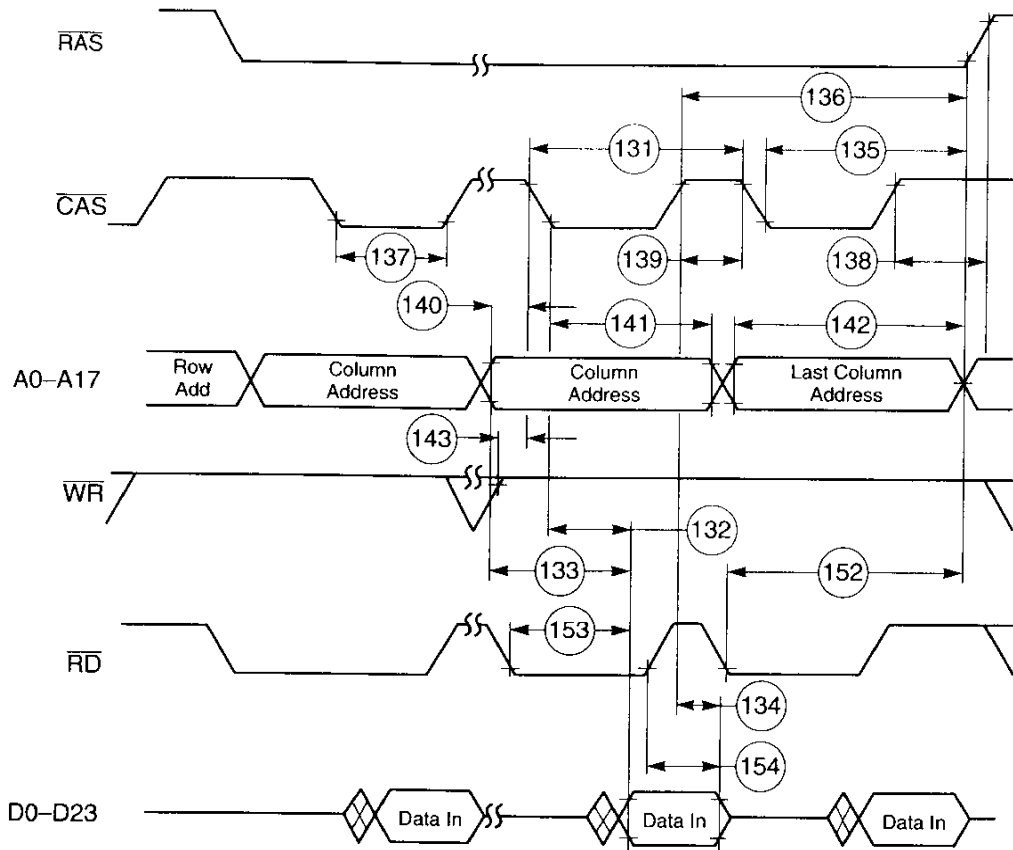

AA0474

Figure 2-16 DRAM Page Mode Read Accesses

Preliminary Information

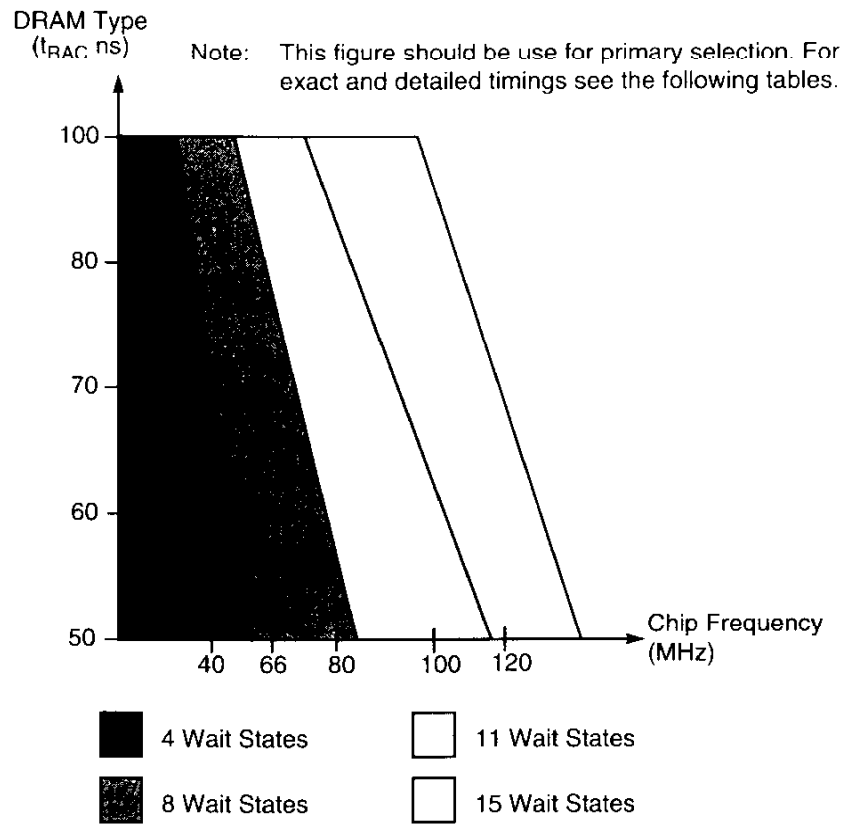

AA0475

Figure 2-17 DRAM Out-of-Page Wait States Selection Guide

Table 2-13 DRAM Out-of-Page and Refresh Timings, Four Wait States<sup>1, 2</sup>

No.	Characteristics <sup>3</sup>	Symbol	Expression	20 MHz <sup>4</sup>		30 MHz <sup>4</sup>		Unit
				Min	Max	Min	Max	
157	Random read or write cycle time	$t_{RC}$	$5 \times T_C$	250.0	—	166.7	—	ns
158	$\overline{RAS}$ assertion to data valid (read)	$t_{RAC}$	$2.75 \times T_C - 7.5$	—	130.0	—	84.2	ns
159	$\overline{CAS}$ assertion to data valid (read)	$t_{CAC}$	$1.25 \times T_C - 7.5$	—	55.0	—	34.2	ns
160	Column address valid to data valid (read)	$t_{AA}$	$1.5 \times T_C - 7.5$	—	67.5	—	42.5	ns
161	$\overline{CAS}$ deassertion to data not valid (read hold time)	$t_{OFF}$		0.0	—	0.0	—	ns

Preliminary Information

## Specifications

### External Memory Interface (Port A)

Table 2-13 DRAM Out-of-Page and Refresh Timings, Four Wait States<sup>1,2</sup> (Continued)

No.	Characteristics <sup>3</sup>	Symbol	Expression	20 MHz <sup>4</sup>		30 MHz <sup>4</sup>		Unit
				Min	Max	Min	Max	
162	RAS deassertion to RAS assertion	$t_{RP}$	$1.75 \times T_C - 4.0$	83.5	—	54.3	—	ns
163	RAS assertion pulse width	$t_{RAS}$	$3.25 \times T_C - 4.0$	158.5	—	104.3	—	ns
164	CAS assertion to RAS deassertion	$t_{RSH}$	$1.75 \times T_C - 4.0$	83.5	—	54.3	—	ns
165	RAS assertion to CAS deassertion	$t_{CSH}$	$2.75 \times T_C - 4.0$	133.5	—	87.7	—	ns
166	CAS assertion pulse width	$t_{CAS}$	$1.25 \times T_C - 4.0$	58.5	—	37.7	—	ns
167	RAS assertion to CAS assertion	$t_{RCD}$	$1.5 \times T_C \pm 2$	73.0	77.0	48.0	52.0	ns
168	RAS assertion to column address valid	$t_{RAD}$	$1.25 \times T_C \pm 2$	60.5	64.5	39.7	43.7	ns
169	CAS deassertion to RAS assertion	$t_{CRP}$	$2.25 \times T_C - 4.0$	108.5	—	71.0	—	ns
170	CAS deassertion pulse width	$t_{CP}$	$1.75 \times T_C - 4.0$	83.5	—	54.3	—	ns
171	Row address valid to RAS assertion	$t_{ASR}$	$1.75 \times T_C - 4.0$	83.5	—	54.3	—	ns
172	RAS assertion to row address not valid	$t_{RAH}$	$1.25 \times T_C - 4.0$	58.5	—	37.7	—	ns
173	Column address valid to CAS assertion	$t_{ASC}$	$0.25 \times T_C - 4.0$	8.5	—	4.3	—	ns
174	CAS assertion to column address not valid	$t_{CAH}$	$1.75 \times T_C - 4.0$	83.5	—	54.3	—	ns
175	RAS assertion to column address not valid	$t_{AR}$	$3.25 \times T_C - 4.0$	158.5	—	104.3	—	ns
176	Column address valid to RAS deassertion	$t_{RAL}$	$2 \times T_C - 4.0$	96.0	—	62.7	—	ns
177	WR deassertion to CAS assertion	$t_{RCS}$	$1.5 \times T_C - 3.8$	71.2	—	46.2	—	ns
178	CAS deassertion to WR assertion	$t_{RCH}$	$0.75 \times T_C - 3.7$	33.8	—	21.3	—	ns
179	RAS deassertion to WR assertion	$t_{RRH}$	$0.25 \times T_C - 3.7$	8.8	—	4.6	—	ns

### Preliminary Information

Table 2-13 DRAM Out-of-Page and Refresh Timings, Four Wait States<sup>1,2</sup> (Continued)

No.	Characteristics <sup>3</sup>	Symbol	Expression	20 MHz <sup>4</sup>		30 MHz <sup>4</sup>		Unit
				Min	Max	Min	Max	
180	$\overline{\text{CAS}}$ assertion to $\overline{\text{WR}}$ deassertion	$t_{\text{WCH}}$	$1.5 \times T_{\text{C}} - 4.2$	70.8	—	45.8	—	ns
181	$\overline{\text{RAS}}$ assertion to $\overline{\text{WR}}$ deassertion	$t_{\text{WCR}}$	$3 \times T_{\text{C}} - 4.2$	145.8	—	95.8	—	ns
182	$\overline{\text{WR}}$ assertion pulse width	$t_{\text{WP}}$	$4.5 \times T_{\text{C}} - 4.5$	220.5	—	145.5	—	ns
183	$\overline{\text{WR}}$ assertion to $\overline{\text{RAS}}$ deassertion	$t_{\text{RWL}}$	$4.75 \times T_{\text{C}} - 4.3$	233.2	—	154.0	—	ns
184	$\overline{\text{WR}}$ assertion to $\overline{\text{CAS}}$ deassertion	$t_{\text{CWL}}$	$4.25 \times T_{\text{C}} - 4.3$	208.2	—	137.4	—	ns
185	Data valid to $\overline{\text{CAS}}$ assertion (write)	$t_{\text{DS}}$	$2.25 \times T_{\text{C}} - 4.0$	108.5	—	71.0	—	ns
186	$\overline{\text{CAS}}$ assertion to data not valid (write)	$t_{\text{DH}}$	$1.75 \times T_{\text{C}} - 4.0$	83.5	—	54.3	—	ns
187	$\overline{\text{RAS}}$ assertion to data not valid (write)	$t_{\text{DHR}}$	$3.25 \times T_{\text{C}} - 4.0$	158.5	—	104.3	—	ns
188	$\overline{\text{WR}}$ assertion to $\overline{\text{CAS}}$ assertion	$t_{\text{WCS}}$	$3 \times T_{\text{C}} - 4.3$	145.7	—	95.7	—	ns
189	$\overline{\text{CAS}}$ assertion to $\overline{\text{RAS}}$ assertion (refresh)	$t_{\text{CSR}}$	$0.5 \times T_{\text{C}} - 4.0$	21.0	—	12.7	—	ns
190	$\overline{\text{RAS}}$ deassertion to $\overline{\text{CAS}}$ assertion (refresh)	$t_{\text{RPC}}$	$1.25 \times T_{\text{C}} - 4.0$	58.5	—	37.7	—	ns
191	$\overline{\text{RD}}$ assertion to $\overline{\text{RAS}}$ deassertion	$t_{\text{ROH}}$	$4.5 \times T_{\text{C}} - 4.0$	221.0	—	146.0	—	ns
192	$\overline{\text{RD}}$ assertion to data valid	$t_{\text{GA}}$	$4 \times T_{\text{C}} - 7.5$	—	192.5	—	125.8	ns
193	$\overline{\text{RD}}$ deassertion to data not valid <sup>3</sup>	$t_{\text{GZ}}$		0.0	—	0.0	—	ns
194	$\overline{\text{WR}}$ assertion to data active		$0.75 \times T_{\text{C}} - 0.3$	37.2	—	24.7	—	ns
195	$\overline{\text{WR}}$ deassertion to data high impedance		$0.25 \times T_{\text{C}}$	—	12.5	—	8.3	ns

Notes:

1. The number of wait states for out-of-page access is specified in the DCR.
2. The refresh period is specified in the DCR.
3.  $\overline{\text{RD}}$  deassertion will always occur after  $\overline{\text{CAS}}$  deassertion; therefore, the restricted timing is  $t_{\text{OFF}}$  and not  $t_{\text{GZ}}$ .
4. Reduced DSP clock speed allows use of DRAM out-of-page access with four wait states (see Figure 2-17).

## Preliminary Information

Specifications

External Memory Interface (Port A)

Table 2-14 DRAM Out-of-Page and Refresh Timings, Eight Wait States<sup>1,2</sup>

No.	Characteristics <sup>4</sup>	Symbol	Expression <sup>3</sup>	66 MHz		80 MHz		100 MHz		Unit
				Min	Max	Min	Max	Min	Max	
157	Random read or write cycle time	$t_{RC}$	$9 \times T_C$	136.4	—	112.5	—	90.0	—	ns
158	RAS assertion to data valid (read)	$t_{RAC}$	66 MHz: $4.75 \times T_C - 7.5$	—	64.5	—	—	—	—	ns
			80 MHz: $4.75 \times T_C - 6.5$	—	—	—	52.9	—	—	ns
			100 MHz: $4.75 \times T_C - 5.7$	—	—	—	—	—	41.8	ns
159	CAS assertion to data valid (read)	$t_{CAC}$	66 MHz: $2.25 \times T_C - 7.5$	—	26.6	—	—	—	—	ns
			80 MHz: $2.25 \times T_C - 6.5$	—	—	—	21.6	—	—	ns
			100 MHz: $2.25 \times T_C - 5.7$	—	—	—	—	—	16.8	ns
160	Column address valid to data valid (read)	$t_{AA}$	66 MHz: $3 \times T_C - 7.5$	—	40.0	—	—	—	—	ns
			80 MHz: $3 \times T_C - 6.5$	—	—	—	31.0	—	—	ns
			100 MHz: $3 \times T_C - 5.7$	—	—	—	—	—	24.3	ns
161	CAS deassertion to data not valid (read hold time)	$t_{OFF}$		0.0	—	0.0	—	0.0	—	ns
162	RAS deassertion to RAS assertion	$t_{RP}$	$3.25 \times T_C - 4.0$	45.2	—	36.6	—	28.5	—	ns
163	RAS assertion pulse width	$t_{RAS}$	$5.75 \times T_C - 4.0$	83.1	—	67.9	—	53.5	—	ns
164	CAS assertion to RAS deassertion	$t_{RSH}$	$3.25 \times T_C - 4.0$	45.2	—	36.6	—	28.5	—	ns
165	RAS assertion to CAS deassertion	$t_{CSH}$	$4.75 \times T_C - 4.0$	68.0	—	55.4	—	43.5	—	ns
166	CAS assertion pulse width	$t_{CAS}$	$2.25 \times T_C - 4.0$	30.1	—	24.1	—	18.5	—	ns
167	RAS assertion to CAS assertion	$t_{RCD}$	$2.5 \times T_C \pm 2$	35.9	39.9	29.3	33.3	23.0	27.0	ns
168	RAS assertion to column address valid	$t_{RAD}$	$1.75 \times T_C \pm 2$	24.5	28.5	19.9	23.9	15.5	19.5	ns
169	CAS deassertion to RAS assertion	$t_{CRP}$	$4.25 \times T_C - 4.0$	59.8	—	49.1	—	38.5	—	ns
170	CAS deassertion pulse width	$t_{CP}$	$2.75 \times T_C - 4.0$	37.7	—	30.4	—	23.5	—	ns

Preliminary Information

Table 2-14 DRAM Out-of-Page and Refresh Timings, Eight Wait States<sup>1,2</sup> (Continued)

No.	Characteristics <sup>4</sup>	Symbol	Expression <sup>3</sup>	66 MHz		80 MHz		100 MHz		Unit	
				Min	Max	Min	Max	Min	Max		
171	Row address valid to $\overline{\text{RAS}}$ assertion	$t_{\text{ASR}}$	$3.25 \times T_C - 4.0$	45.2	—	36.6	—	28.5	—	ns	
172	$\overline{\text{RAS}}$ assertion to row address not valid	$t_{\text{RAH}}$	$1.75 \times T_C - 4.0$	22.5	—	17.9	—	13.5	—	ns	
173	Column address valid to $\overline{\text{CAS}}$ assertion	$t_{\text{ASC}}$	$0.75 \times T_C - 4.0$	7.4	—	5.4	—	3.5	—	ns	
174	$\overline{\text{CAS}}$ assertion to column address not valid	$t_{\text{CAH}}$	$3.25 \times T_C - 4.0$	45.2	—	36.6	—	28.5	—	ns	
175	$\overline{\text{RAS}}$ assertion to column address not valid	$t_{\text{AR}}$	$5.75 \times T_C - 4.0$	83.1	—	67.9	—	53.5	—	ns	
176	Column address valid to $\overline{\text{RAS}}$ deassertion	$t_{\text{RAL}}$	$4 \times T_C - 4.0$	56.6	—	46.0	—	36.0	—	ns	
177	$\overline{\text{WR}}$ deassertion to $\overline{\text{CAS}}$ assertion	$t_{\text{RCS}}$	$2 \times T_C - 3.8$	26.5	—	21.2	—	16.2	—	ns	
178	$\overline{\text{CAS}}$ deassertion to $\overline{\text{WR}}$ <sup>5</sup> assertion	$t_{\text{RCH}}$	$1.25 \times T_C - 3.7$	15.2	—	11.9	—	8.8	—	ns	
179	$\overline{\text{RAS}}$ deassertion to $\overline{\text{WR}}$ <sup>5</sup> assertion	$t_{\text{RRH}}$	66 MHz: $0.25 \times T_C - 3.7$	0.1	—	—	—	—	—	ns	
				80 MHz: $0.25 \times T_C - 3.0$	—	—	0.1	—	—	—	ns
				100 MHz: $0.25 \times T_C - 2.4$	—	—	—	—	0.1	—	ns
180	$\overline{\text{CAS}}$ assertion to $\overline{\text{WR}}$ deassertion	$t_{\text{WCH}}$	$3 \times T_C - 4.2$	41.3	—	33.3	—	25.8	—	ns	
181	$\overline{\text{RAS}}$ assertion to $\overline{\text{WR}}$ deassertion	$t_{\text{WCR}}$	$5.5 \times T_C - 4.2$	79.1	—	64.6	—	50.8	—	ns	
182	$\overline{\text{WR}}$ assertion pulse width	$t_{\text{WP}}$	$8.5 \times T_C - 4.5$	124.3	—	101.8	—	80.5	—	ns	
183	$\overline{\text{WR}}$ assertion to $\overline{\text{RAS}}$ deassertion	$t_{\text{RWL}}$	$8.75 \times T_C - 4.3$	128.3	—	105.1	—	83.2	—	ns	
184	$\overline{\text{WR}}$ assertion to $\overline{\text{CAS}}$ deassertion	$t_{\text{CWL}}$	$7.75 \times T_C - 4.3$	113.1	—	92.6	—	73.2	—	ns	
185	Data valid to $\overline{\text{CAS}}$ assertion (write)	$t_{\text{DS}}$	$4.75 \times T_C - 4.0$	68.0	—	55.4	—	43.5	—	ns	
186	$\overline{\text{CAS}}$ assertion to data not valid (write)	$t_{\text{DH}}$	$3.25 \times T_C - 4.0$	45.2	—	36.6	—	28.5	—	ns	
187	$\overline{\text{RAS}}$ assertion to data not valid (write)	$t_{\text{DIR}}$	$5.75 \times T_C - 4.0$	83.1	—	67.9	—	53.5	—	ns	

## Preliminary Information

**Specifications**

**External Memory Interface (Port A)**

**Table 2-14** DRAM Out-of-Page and Refresh Timings, Eight Wait States<sup>1,2</sup> (Continued)

No.	Characteristics <sup>4</sup>	Symbol	Expression <sup>3</sup>	66 MHz		80 MHz		100 MHz		Unit
				Min	Max	Min	Max	Min	Max	
188	WR assertion to $\overline{\text{CAS}}$ assertion	$t_{\text{WCS}}$	$5.5 \times T_{\text{C}} - 4.3$	79.0	—	64.5	—	50.7	—	ns
189	CAS assertion to $\overline{\text{RAS}}$ assertion (refresh)	$t_{\text{CSR}}$	$1.5 \times T_{\text{C}} - 4.0$	18.7	—	14.8	—	11.0	—	ns
190	$\overline{\text{RAS}}$ deassertion to $\overline{\text{CAS}}$ assertion (refresh)	$t_{\text{RPC}}$	$1.75 \times T_{\text{C}} - 4.0$	22.5	—	17.9	—	13.5	—	ns
191	RD assertion to $\overline{\text{RAS}}$ deassertion	$t_{\text{ROH}}$	$8.5 \times T_{\text{C}} - 4.0$	124.8	—	102.3	—	81.0	—	ns
192	RD assertion to data valid	$t_{\text{GA}}$	<b>66 MHz:</b> $7.5 \times T_{\text{C}} - 7.5$ <b>80 MHz:</b> $7.5 \times T_{\text{C}} - 6.5$ <b>100 MHz:</b> $7.5 \times T_{\text{C}} - 5.7$	—	106.1	—	—	—	—	ns
				—	—	—	87.3	—	—	ns
				—	—	—	—	—	69.3	ns
193	$\overline{\text{RD}}$ deassertion to data not valid <sup>4</sup>	$t_{\text{GZ}}$	0.0	0.0	—	0.0	—	0.0	—	ns
194	$\overline{\text{WR}}$ assertion to data active		$0.75 \times T_{\text{C}} - 0.3$	11.1	—	9.1	—	7.2	—	ns
195	$\overline{\text{WR}}$ deassertion to data high impedance		$0.25 \times T_{\text{C}}$	—	3.8	—	3.1	—	2.5	ns

- Notes:
1. The number of wait states for out-of-page access is specified in the DCR.
  2. The refresh period is specified in the DCR.
  3. The asynchronous delays specified in the expressions are valid for DSP56302A.
  4.  $\overline{\text{RD}}$  deassertion will always occur after  $\overline{\text{CAS}}$  deassertion; therefore, the restricted timing is  $t_{\text{OFF}}$  and not  $t_{\text{GZ}}$ .
  5. Either  $t_{\text{RCH}}$  or  $t_{\text{RRH}}$  must be satisfied for read cycles.



Table 2-15 DRAM Out-of-Page and Refresh Timings, Eleven Wait States<sup>1,2</sup>

No.	Characteristics <sup>4</sup>	Symbol	Expression <sup>3</sup>	66 MHz		80 MHz		100 MHz		Unit
				Min	Max	Min	Max	Min	Max	
157	Random read or write cycle time	$t_{RC}$	$12 \times T_C$	181.8	—	150.0	—	120.0	—	ns
158	$\overline{RAS}$ assertion to data valid (read)	$t_{RAC}$	66 MHz: $6.25 \times T_C - 7.5$	—	87.2	—	—	—	—	ns
			80 MHz: $6.25 \times T_C - 6.5$	—	—	—	71.6	—	—	ns
			100 MHz: $6.25 \times T_C - 5.7$	—	—	—	—	—	56.8	ns
159	$\overline{CAS}$ assertion to data valid (read)	$t_{CAC}$	66 MHz: $3.75 \times T_C - 7.5$	—	49.3	—	—	—	—	ns
			80 MHz: $3.75 \times T_C - 6.5$	—	—	—	40.4	—	—	ns
			100 MHz: $3.75 \times T_C - 5.7$	—	—	—	—	—	31.8	ns
160	Column address valid to data valid (read)	$t_{AA}$	66 MHz: $4.5 \times T_C - 7.5$	—	60.7	—	—	—	—	ns
			80 MHz: $4.5 \times T_C - 6.5$	—	—	—	49.8	—	—	ns
			100 MHz: $4.5 \times T_C - 5.7$	—	—	—	—	—	39.3	ns
161	$\overline{CAS}$ deassertion to data not valid (read hold time)	$t_{OFF}$		0.0	—	0.0	—	0.0	—	ns
162	$\overline{RAS}$ deassertion to $\overline{RAS}$ assertion	$t_{RP}$	$4.25 \times T_C - 4.0$	60.4	—	49.1	—	38.5	—	ns
163	$\overline{RAS}$ assertion pulse width	$t_{RAS}$	$7.75 \times T_C - 4.0$	113.4	—	92.9	—	73.5	—	ns
164	$\overline{CAS}$ assertion to $\overline{RAS}$ deassertion	$t_{RSH}$	$5.25 \times T_C - 4.0$	75.5	—	61.6	—	48.5	—	ns
165	$\overline{RAS}$ assertion to $\overline{CAS}$ deassertion	$t_{CSH}$	$6.25 \times T_C - 4.0$	90.7	—	74.1	—	58.5	—	ns
166	$\overline{CAS}$ assertion pulse width	$t_{CAS}$	$3.75 \times T_C - 4.0$	52.8	—	42.9	—	33.5	—	ns
167	$\overline{RAS}$ assertion to $\overline{CAS}$ assertion	$t_{RCD}$	$2.5 \times T_C \pm 2$	35.9	39.9	29.3	33.3	23.0	27.0	ns
168	$\overline{RAS}$ assertion to column address valid	$t_{RAD}$	$1.75 \times T_C \pm 2$	24.5	28.5	19.9	23.9	15.5	19.5	ns
169	$\overline{CAS}$ deassertion to $\overline{RAS}$ assertion	$t_{CRP}$	$5.75 \times T_C - 4.0$	83.1	—	67.9	—	53.5	—	ns
170	$\overline{CAS}$ deassertion pulse width	$t_{CP}$	$4.25 \times T_C - 4.0$	60.4	—	49.1	—	38.5	—	ns

## Preliminary Information

## Specifications

### External Memory Interface (Port A)

Table 2-15 DRAM Out-of-Page and Refresh Timings, Eleven Wait States<sup>1,2</sup> (Continued)

No.	Characteristics <sup>4</sup>	Symbol	Expression <sup>3</sup>	66 MHz		80 MHz		100 MHz		Unit
				Min	Max	Min	Max	Min	Max	
171	Row address valid to $\overline{\text{RAS}}$ assertion	$t_{\text{ASR}}$	$4.25 \times T_C - 4.0$	60.4	—	49.1	—	38.5	—	ns
172	$\overline{\text{RAS}}$ assertion to row address not valid	$t_{\text{RAH}}$	$1.75 \times T_C - 4.0$	22.5	—	17.9	—	13.5	—	ns
173	Column address valid to $\overline{\text{CAS}}$ assertion	$t_{\text{ASC}}$	$0.75 \times T_C - 4.0$	7.4	—	5.4	—	3.5	—	ns
174	$\overline{\text{CAS}}$ assertion to column address not valid	$t_{\text{CAH}}$	$5.25 \times T_C - 4.0$	75.5	—	61.6	—	48.5	—	ns
175	$\overline{\text{RAS}}$ assertion to column address not valid	$t_{\text{AR}}$	$7.75 \times T_C - 4.0$	113.4	—	92.9	—	73.5	—	ns
176	Column address valid to $\overline{\text{RAS}}$ deassertion	$t_{\text{RAL}}$	$6 \times T_C - 4.0$	86.9	—	71.0	—	56.0	—	ns
177	$\overline{\text{WR}}$ deassertion to $\overline{\text{CAS}}$ assertion	$t_{\text{RCS}}$	$3.0 \times T_C - 3.8$	41.7	—	33.7	—	26.2	—	ns
178	$\overline{\text{CAS}}$ deassertion to $\overline{\text{WR}}$ <sup>5</sup> assertion	$t_{\text{RCH}}$	$1.75 \times T_C - 3.7$	22.8	—	18.2	—	13.8	—	ns
179	$\overline{\text{RAS}}$ deassertion to $\overline{\text{WR}}$ <sup>5</sup> assertion	$t_{\text{RRH}}$	<b>66 MHz:</b> $0.25 \times T_C - 3.7$ <b>80 MHz:</b> $0.25 \times T_C - 3.0$ <b>100 MHz:</b> $0.25 \times T_C - 2.4$	0.1	—	—	—	—	—	ns
				—	—	0.1	—	—	—	ns
				—	—	—	—	0.1	—	ns
				—	—	—	—	—	0.1	ns
180	$\overline{\text{CAS}}$ assertion to $\overline{\text{WR}}$ deassertion	$t_{\text{WCH}}$	$5 \times T_C - 4.2$	71.6	—	58.3	—	45.8	—	ns
181	$\overline{\text{RAS}}$ assertion to $\overline{\text{WR}}$ deassertion	$t_{\text{WCR}}$	$7.5 \times T_C - 4.2$	109.4	—	89.6	—	70.8	—	ns
182	$\overline{\text{WR}}$ assertion pulse width	$t_{\text{WP}}$	$11.5 \times T_C - 4.5$	169.7	—	139.3	—	110.5	—	ns
183	$\overline{\text{WR}}$ assertion to $\overline{\text{RAS}}$ deassertion	$t_{\text{RWL}}$	$11.75 \times T_C - 4.3$	173.7	—	142.7	—	113.2	—	ns
184	$\overline{\text{WR}}$ assertion to $\overline{\text{CAS}}$ deassertion	$t_{\text{CWL}}$	$10.25 \times T_C - 4.3$	151.0	—	130.1	—	103.2	—	ns
185	Data valid to $\overline{\text{CAS}}$ assertion (write)	$t_{\text{DS}}$	$5.75 \times T_C - 4.0$	83.1	—	67.9	—	53.5	—	ns
186	$\overline{\text{CAS}}$ assertion to data not valid (write)	$t_{\text{DI}}$	$5.25 \times T_C - 4.0$	75.5	—	61.6	—	48.5	—	ns
187	$\overline{\text{RAS}}$ assertion to data not valid (write)	$t_{\text{DIR}}$	$7.75 \times T_C - 4.0$	113.4	—	92.9	—	73.5	—	ns

### Preliminary Information

Table 2-15 DRAM Out-of-Page and Refresh Timings, Eleven Wait States<sup>1,2</sup> (Continued)

No.	Characteristics <sup>4</sup>	Symbol	Expression <sup>3</sup>	66 MHz		80 MHz		100 MHz		Unit
				Min	Max	Min	Max	Min	Max	
188	$\overline{WR}$ assertion to $\overline{CAS}$ assertion	$t_{WCS}$	$6.5 \times T_C - 4.3$	94.2	—	77.0	—	60.7	—	ns
189	$\overline{CAS}$ assertion to $\overline{RAS}$ assertion (refresh)	$t_{CSR}$	$1.5 \times T_C - 4.0$	18.7	—	14.8	—	11.0	—	ns
190	$\overline{RAS}$ deassertion to $\overline{CAS}$ assertion (refresh)	$t_{RPC}$	$2.75 \times T_C - 4.0$	37.7	—	30.4	—	23.5	—	ns
191	$\overline{RD}$ assertion to $\overline{RAS}$ deassertion	$t_{ROH}$	$11.5 \times T_C - 4.0$	170.2	—	139.8	—	111.0	—	ns
192	$\overline{RD}$ assertion to data valid	$t_{GA}$	<b>66 MHz:</b> $10 \times T_C - 7.5$ <b>80 MHz:</b> $10 \times T_C - 6.5$ <b>100 MHz:</b> $10 \times T_C - 5.7$	—	144.0	—	—	—	—	ns
				—	—	—	118.5	—	—	ns
				—	—	—	—	—	94.3	ns
193	$\overline{RD}$ deassertion to data not valid <sup>4</sup>	$t_{GZ}$		0.0	—	0.0	—	0.0	—	ns
194	$\overline{WR}$ assertion to data active		$0.75 \times T_C - 0.3$	11.1	—	9.1	—	7.2	—	ns
195	$\overline{WR}$ deassertion to data high impedance		$0.25 \times T_C$	—	3.8	—	3.1	—	2.5	ns

Notes: 1. The number of wait states for out-of-page access is specified in the DCR.  
2. The refresh period is specified in the DCR.  
3. The asynchronous delays specified in the expressions are valid for DSP56302A.  
4.  $\overline{RD}$  deassertion will always occur after  $\overline{CAS}$  deassertion; therefore, the restricted timing is  $t_{OFF}$  and not  $t_{GZ}$ .  
5. Either  $t_{RCH}$  or  $t_{RRH}$  must be satisfied for read cycles.

**Specifications**

**External Memory Interface (Port A)**

**Table 2-16** DRAM Out-of-Page and Refresh Timings, Fifteen Wait States<sup>1,2</sup>

No.	Characteristics <sup>3</sup>	Symbol	Expression	66 MHz		80 MHz		100 MHz		Unit
				Min	Max	Min	Max	Min	Max	
157	Random read or write cycle time	$t_{RC}$	$16 \times T_C$	242.4	—	200.0	—	160.0	—	ns
158	RAS assertion to data valid (read)	$t_{RAC}$	66 MHz: $8.25 \times T_C - 7.5$	—	117.5	—	—	—	—	ns
			80 MHz: $8.25 \times T_C - 6.5$	—	—	—	96.6	—	—	ns
			100 MHz: $8.25 \times T_C - 5.7$	—	—	—	—	—	76.8	ns
159	CAS assertion to data valid (read)	$t_{CAC}$	66 MHz: $4.75 \times T_C - 7.5$	—	64.5	—	—	—	—	ns
			80 MHz: $4.75 \times T_C - 6.5$	—	—	—	52.9	—	—	ns
			100 MHz: $4.75 \times T_C - 5.7$	—	—	—	—	—	41.8	ns
160	Column address valid to data valid (read)	$t_{AA}$	66 MHz: $5.5 \times T_C - 7.5$	—	75.8	—	—	—	—	ns
			80 MHz: $5.5 \times T_C - 6.5$	—	—	—	62.3	—	—	ns
			100 MHz: $5.5 \times T_C - 5.7$	—	—	—	—	—	49.3	ns
161	CAS deassertion to data not valid (read hold time)	$t_{OFF}$	0.0	0.0	—	0.0	—	0.0	—	ns
162	RAS deassertion to RAS assertion	$t_{RP}$	$6.25 \times T_C - 4.0$	90.7	—	74.1	—	58.5	—	ns
163	RAS assertion pulse width	$t_{RAS}$	$9.75 \times T_C - 4.0$	143.7	—	117.9	—	93.5	—	ns
164	CAS assertion to RAS deassertion	$t_{RSH}$	$6.25 \times T_C - 4.0$	90.7	—	74.1	—	58.5	—	ns
165	RAS assertion to CAS deassertion	$t_{CSH}$	$8.25 \times T_C - 4.0$	121.0	—	99.1	—	78.5	—	ns
166	CAS assertion pulse width	$t_{CAS}$	$4.75 \times T_C - 4.0$	68.0	—	55.4	—	43.5	—	ns
167	RAS assertion to CAS assertion	$t_{RCD}$	$3.5 \times T_C \pm 2$	51.0	55.0	41.8	45.8	33.0	37.0	ns
168	RAS assertion to column address valid	$t_{RAD}$	$2.75 \times T_C \pm 2$	39.7	43.7	32.4	36.4	25.5	29.5	ns
169	CAS deassertion to RAS assertion	$t_{CRP}$	$7.75 \times T_C - 4.0$	113.4	—	92.9	—	73.5	—	ns
170	CAS deassertion pulse width	$t_{CP}$	$6.25 \times T_C - 4.0$	90.7	—	74.1	—	58.5	—	ns

**Preliminary Information**

Table 2-16 DRAM Out-of-Page and Refresh Timings, Fifteen Wait States<sup>1,2</sup> (Continued)

No.	Characteristics <sup>3</sup>	Symbol	Expression	66 MHz		80 MHz		100 MHz		Unit
				Min	Max	Min	Max	Min	Max	
171	Row address valid to $\overline{\text{RAS}}$ assertion	$t_{\text{ASR}}$	$6.25 \times T_C - 4.0$	90.7	—	74.1	—	58.5	—	ns
172	$\overline{\text{RAS}}$ assertion to row address not valid	$t_{\text{RAH}}$	$2.75 \times T_C - 4.0$	37.7	—	30.4	—	23.5	—	ns
173	Column address valid to $\overline{\text{CAS}}$ assertion	$t_{\text{ASC}}$	$0.75 \times T_C - 4.0$	7.4	—	5.4	—	3.5	—	ns
174	$\overline{\text{CAS}}$ assertion to column address not valid	$t_{\text{CAH}}$	$6.25 \times T_C - 4.0$	90.7	—	74.1	—	58.5	—	ns
175	$\overline{\text{RAS}}$ assertion to column address not valid	$t_{\text{AR}}$	$9.75 \times T_C - 4.0$	143.7	—	117.9	—	93.5	—	ns
176	Column address valid to $\overline{\text{RAS}}$ deassertion	$t_{\text{RAL}}$	$7 \times T_C - 4.0$	102.1	—	83.5	—	66.0	—	ns
177	$\overline{\text{WR}}$ deassertion to $\overline{\text{CAS}}$ assertion	$t_{\text{RCS}}$	$5 \times T_C - 3.8$	72.0	—	58.7	—	46.2	—	ns
178	$\overline{\text{CAS}}$ deassertion to $\overline{\text{WR}}$ <sup>5</sup> assertion	$t_{\text{RCH}}$	$1.75 \times T_C - 3.7$	22.8	—	18.2	—	13.8	—	ns
179	$\overline{\text{RAS}}$ deassertion to $\overline{\text{WR}}$ <sup>5</sup> assertion	$t_{\text{RRH}}$	66 MHz: $0.25 \times T_C - 3.7$	0.1	—	—	—	—	—	ns
				80 MHz: $0.25 \times T_C - 3.0$	—	—	0.1	—	—	ns
				100 MHz: $0.25 \times T_C - 2.4$	—	—	—	—	0.1	ns
180	$\overline{\text{CAS}}$ assertion to $\overline{\text{WR}}$ deassertion	$t_{\text{WCH}}$	$6 \times T_C - 4.2$	86.7	—	70.8	—	55.8	—	ns
181	$\overline{\text{RAS}}$ assertion to $\overline{\text{WR}}$ deassertion	$t_{\text{WCR}}$	$9.5 \times T_C - 4.2$	139.7	—	114.6	—	90.8	—	ns
182	$\overline{\text{WR}}$ assertion pulse width	$t_{\text{WP}}$	$15.5 \times T_C - 4.5$	230.3	—	189.3	—	150.5	—	ns
183	$\overline{\text{WR}}$ assertion to $\overline{\text{RAS}}$ deassertion	$t_{\text{RWL}}$	$15.75 \times T_C - 4.3$	234.3	—	192.6	—	153.2	—	ns
184	$\overline{\text{WR}}$ assertion to $\overline{\text{CAS}}$ deassertion	$t_{\text{CWL}}$	66–80 MHz: $14.25 \times T_C - 4.3$	211.6	—	180.1	—	—	—	ns
				100 MHz: $14.75 \times T_C - 4.3$	—	—	—	—	143.2	ns
185	Data valid to $\overline{\text{CAS}}$ assertion (write)	$t_{\text{DS}}$	$8.75 \times T_C - 4.0$	128.6	—	105.4	—	83.5	—	ns
186	$\overline{\text{CAS}}$ assertion to data not valid (write)	$t_{\text{DH}}$	$6.25 \times T_C - 4.0$	90.7	—	74.1	—	58.5	—	ns

## Preliminary Information

Specifications

External Memory Interface (Port A)

Table 2-16 DRAM Out-of-Page and Refresh Timings, Fifteen Wait States<sup>1,2</sup> (Continued)

No.	Characteristics <sup>3</sup>	Symbol	Expression	66 MHz		80 MHz		100 MHz		Unit
				Min	Max	Min	Max	Min	Max	
187	$\overline{\text{RAS}}$ assertion to data not valid (write)	$t_{\text{DHR}}$	$9.75 \times T_C - 4.0$	143.7	—	117.9	—	93.5	—	ns
188	$\overline{\text{WR}}$ assertion to $\overline{\text{CAS}}$ assertion	$t_{\text{WCS}}$	$9.5 \times T_C - 4.3$	139.6	—	114.5	—	90.7	—	ns
189	$\overline{\text{CAS}}$ assertion to $\overline{\text{RAS}}$ assertion (refresh)	$t_{\text{CSR}}$	$1.5 \times T_C - 4.0$	18.7	—	14.8	—	11.0	—	ns
190	$\overline{\text{RAS}}$ deassertion to $\overline{\text{CAS}}$ assertion (refresh)	$t_{\text{RPC}}$	$4.75 \times T_C - 4.0$	68.0	—	55.4	—	43.5	—	ns
191	$\overline{\text{RD}}$ assertion to $\overline{\text{RAS}}$ deassertion	$t_{\text{ROH}}$	$15.5 \times T_C - 4.0$	230.8	—	189.8	—	151.0	—	ns
192	$\overline{\text{RD}}$ assertion to data valid	$t_{\text{GA}}$	<b>66 MHz:</b> $14 \times T_C - 7.5$ <b>80 MHz:</b> $14 \times T_C - 6.5$ <b>100 MHz:</b> $14 \times T_C - 5.7$	—	204.6	—	—	—	—	ns
				—	—	—	168.5	—	—	ns
				—	—	—	—	—	134.3	ns
193	$\overline{\text{RD}}$ deassertion to data not valid <sup>3</sup>	$t_{\text{GZ}}$		0.0	—	0.0	—	0.0	—	ns
194	$\overline{\text{WR}}$ assertion to data active		$0.75 \times T_C - 0.3$	11.1	—	9.1	—	7.2	—	ns
195	$\overline{\text{WR}}$ deassertion to data high impedance		$0.25 \times T_C$	—	3.8	—	3.1	—	2.5	ns

Notes: 1. The number of wait states for out-of-page access is specified in the DCR.  
 2. The refresh period is specified in the DCR.  
 3.  $\overline{\text{RD}}$  deassertion will always occur after  $\overline{\text{CAS}}$  deassertion; therefore, the restricted timing is  $t_{\text{OFF}}$  and not  $t_{\text{GZ}}$ .  
 4. Either  $t_{\text{RCH}}$  or  $t_{\text{RRH}}$  must be satisfied for read cycles.

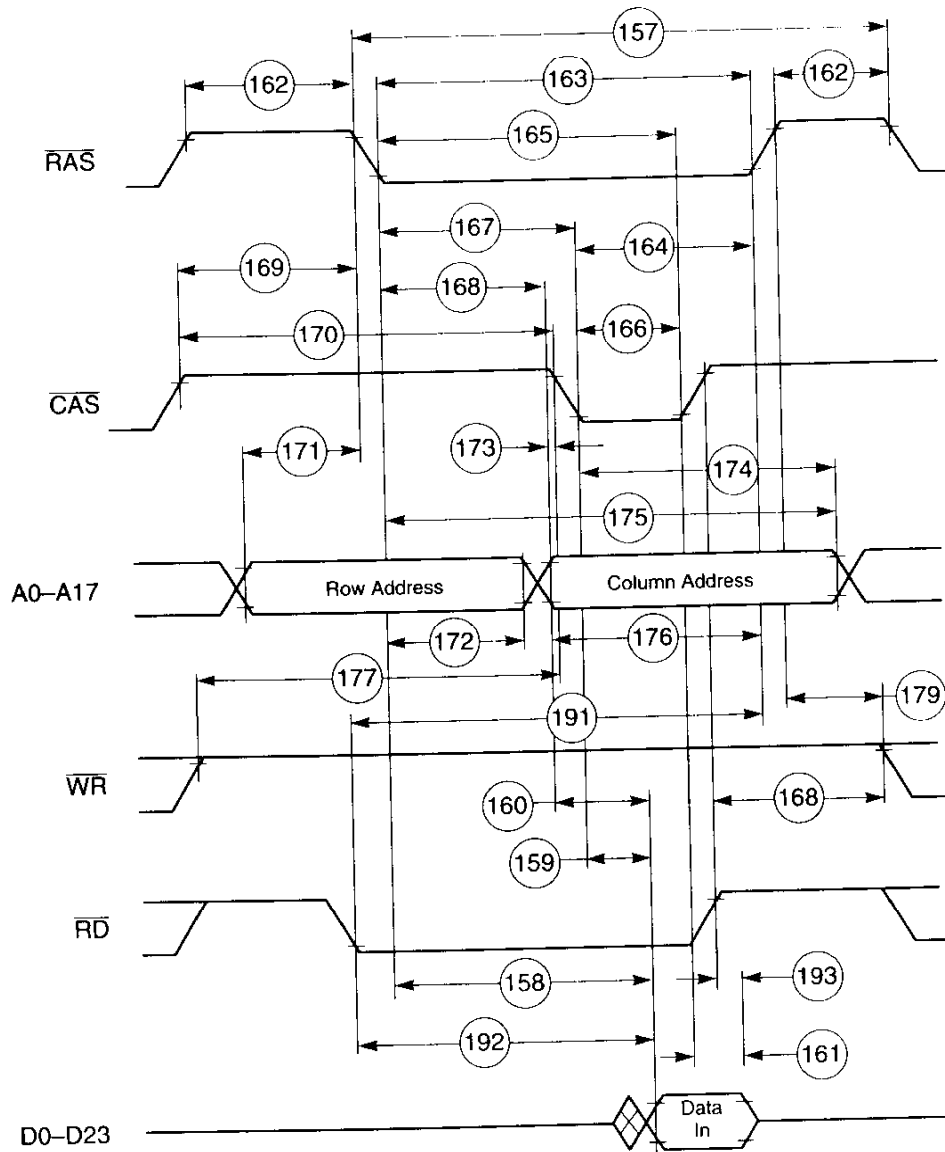

AA0476

Figure 2-18 DRAM Out-of-Page Read Access

Preliminary Information

Specifications

External Memory Interface (Port A)

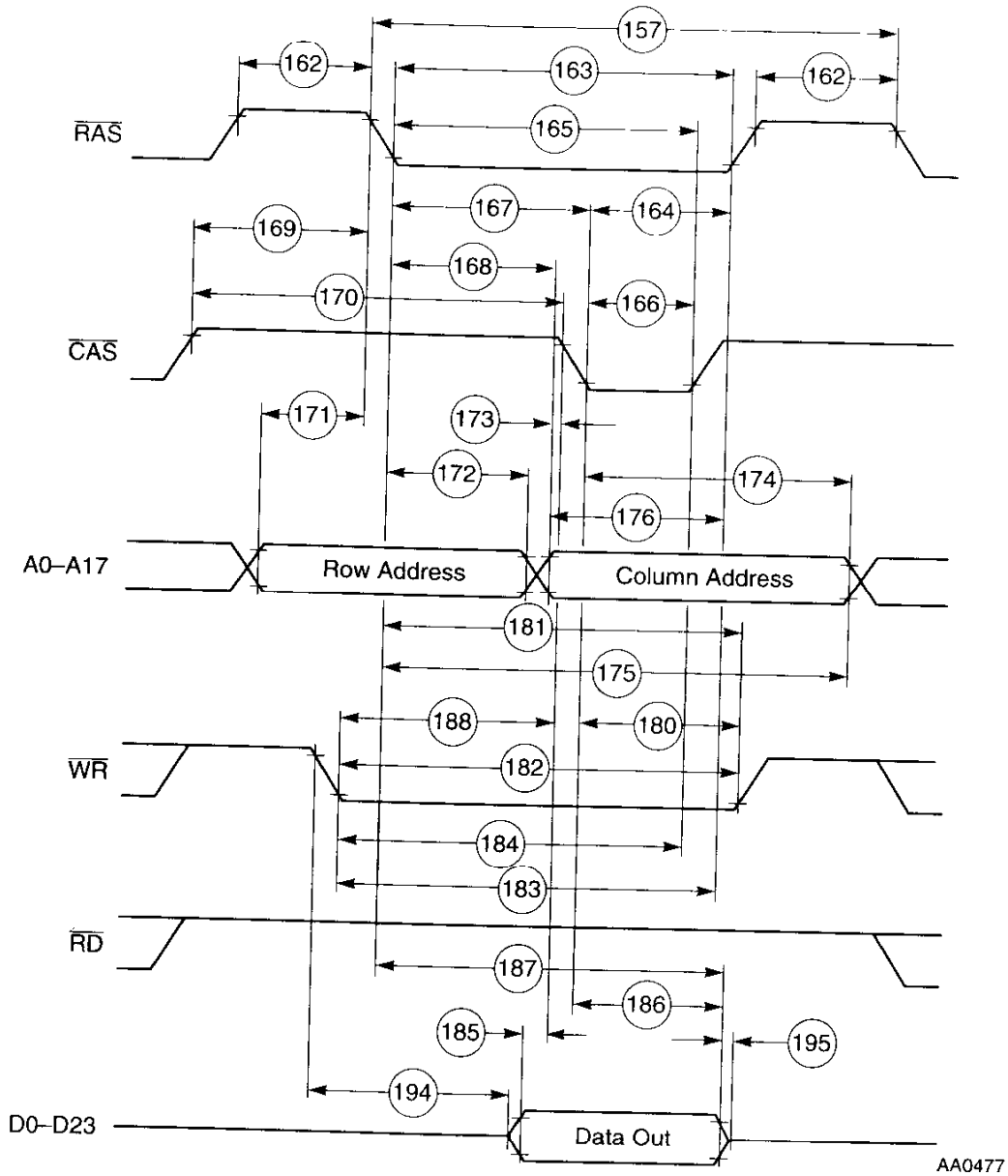

Figure 2-19 DRAM Out-of-Page Write Access

Preliminary Information



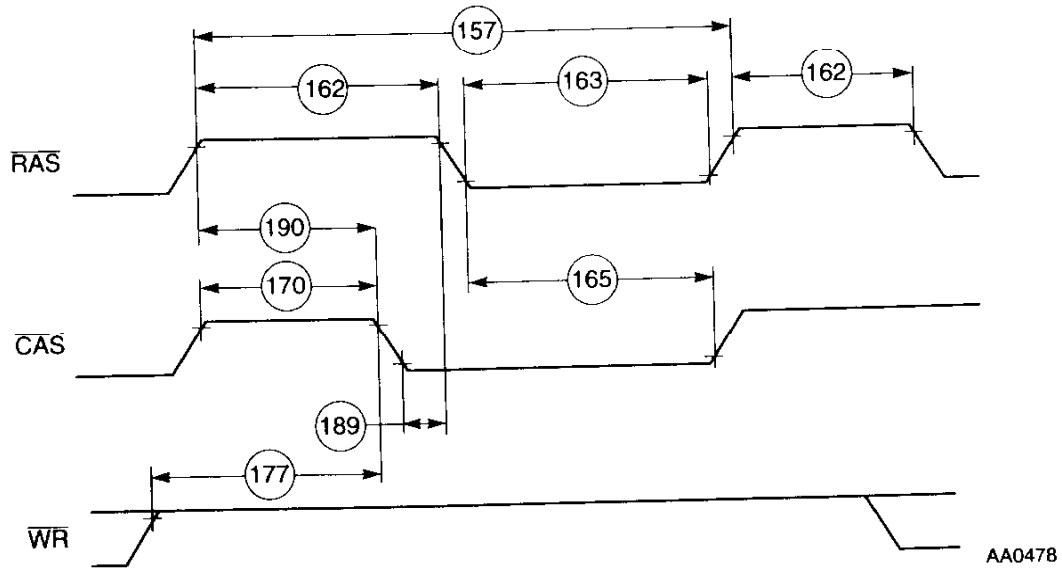

Figure 2-20 DRAM Refresh Access

## Synchronous Timings (SRAM)

Table 2-17 External Bus Synchronous Timings (SRAM Access)<sup>4</sup>

No.	Characteristics	Expression <sup>1,2</sup>	66 MHz		80 MHz		100 MHz		Unit
			Min	Max	Min	Max	Min	Max	
198	CLKOUT high to address, and AA valid <sup>5</sup>	66 MHz: $0.25 \times T_C + 5.0$	—	8.8	—	—	—	—	ns
		80 MHz: $0.25 \times T_C + 4.5$	—	—	—	7.6	—	—	ns
		100 MHz: $0.25 \times T_C + 4.0$	—	—	—	—	—	6.5	ns
199	CLKOUT high to address, and AA invalid <sup>5</sup>	$0.25 \times T_C$	3.8	—	3.1	—	2.5	—	ns
200	$\overline{TA}$ valid to CLKOUT high (setup time)		6.0	—	5.0	—	4.0	—	ns
201	CLKOUT high to $\overline{TA}$ invalid (hold time)		0.0	—	0.0	—	0.0	—	ns
202	CLKOUT high to data out active	$0.25 \times T_C$	3.8	—	3.1	—	2.5	—	ns
203	CLKOUT high to data out valid	66 MHz: $0.25 \times T_C + 5.0$	4.8	8.8	—	—	—	—	ns
		80 MHz: $0.25 \times T_C + 4.5$	—	—	4.1	7.6	—	—	ns
		100 MHz: $0.25 \times T_C + 4.0$	—	—	—	—	3.3	6.5	ns
204	CLKOUT high to data out invalid	$0.25 \times T_C$	3.8	—	3.1	—	2.5	—	ns
205	CLKOUT high to data out high impedance	66 MHz: $0.25 \times T_C + 1.0$	—	4.8	—	—	—	—	ns
		80 MHz: $0.25 \times T_C + 0.5$	—	—	—	3.6	—	—	ns
		100 MHz: $0.25 \times T_C$	—	—	—	—	—	2.5	ns
206	Data in valid to CLKOUT high (setup)		6.0	—	5.0	—	4.0	—	ns
207	CLKOUT high to data in invalid (hold)		0.0	—	0.0	—	0.0	—	ns
208	CLKOUT high to $\overline{RD}$ assertion	66 MHz: $0.75 \times T_C + 5.0$	12.4	16.4	—	—	—	—	ns
		80 MHz: $0.75 \times T_C + 4.5$	—	—	10.4	13.9	—	—	ns
		100 MHz: $0.75 \times T_C + 4.0$	—	—	—	—	8.2	11.5	ns
209	CLKOUT high to $\overline{RD}$ deassertion		0.0	5.0	0.0	4.5	0.0	4.0	ns

## Preliminary Information

Table 2-17 External Bus Synchronous Timings (SRAM Access)<sup>4</sup> (Continued)

No.	Characteristics	Expression <sup>1,2</sup>	66 MHz		80 MHz		100 MHz		Unit
			Min	Max	Min	Max	Min	Max	
210	CLKOUT high to $\overline{WR}$ assertion <sup>3</sup>	<b>66 MHz:</b> $0.5 \times T_C + 5.3$ [WS = 1 or WS $\geq$ 4]	8.9	12.9	—	—	—	—	ns
		<b>80 MHz:</b> $0.5 \times T_C + 4.8$ [WS = 1 or WS $\geq$ 4]	—	—	7.6	11.1	—	—	ns
		<b>100 MHz:</b> $0.5 \times T_C + 4.3$ [WS = 1 or WS $\geq$ 4]	—	—	—	—	6.3	9.3	ns
		<b>All frequencies:</b> [2 $\leq$ WS $\leq$ 3]	1.3	5.3	1.3	4.8	1.3	4.3	ns
211	CLKOUT high to $\overline{WR}$ deassertion		0.0	4.8	0.0	4.3	0.0	3.8	ns

Notes:

1. WS is the number of wait states specified in the BCR.
2. The asynchronous delays specified in the expressions are valid for DSP56302A.
3. If WS > 1,  $\overline{WR}$  assertion refers to the next rising edge of CLKOUT.
4. External bus synchronous timings should be used only for reference to the clock and *not* for relative timings.
5. T198 and T199 are valid for Address Trace mode if the ATE bit in the OMR is set. Use the status of  $\overline{BR}$  (See T212) to determine whether the access referenced by A0-A23 is internal or external, when this mode is enabled.

Specifications

External Memory Interface (Port A)

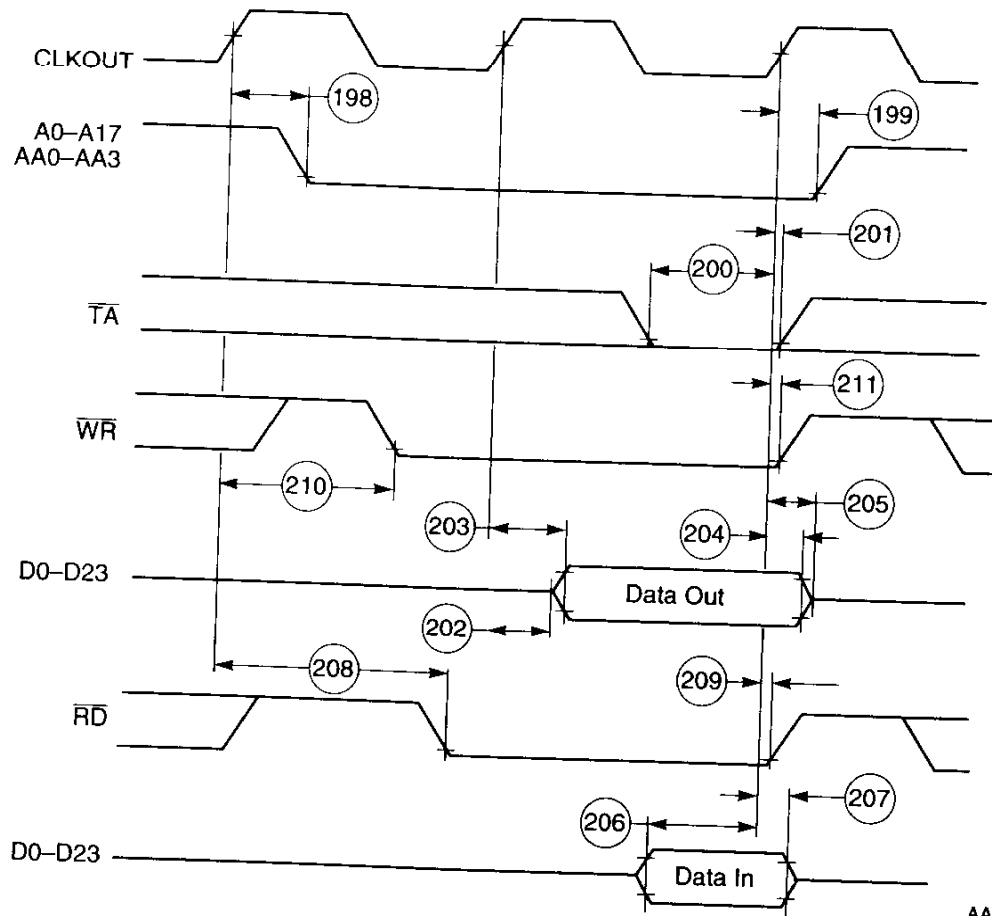

AA0479

Figure 2-21 Synchronous Bus Timings SRAM 1 WS (BCR Controlled)

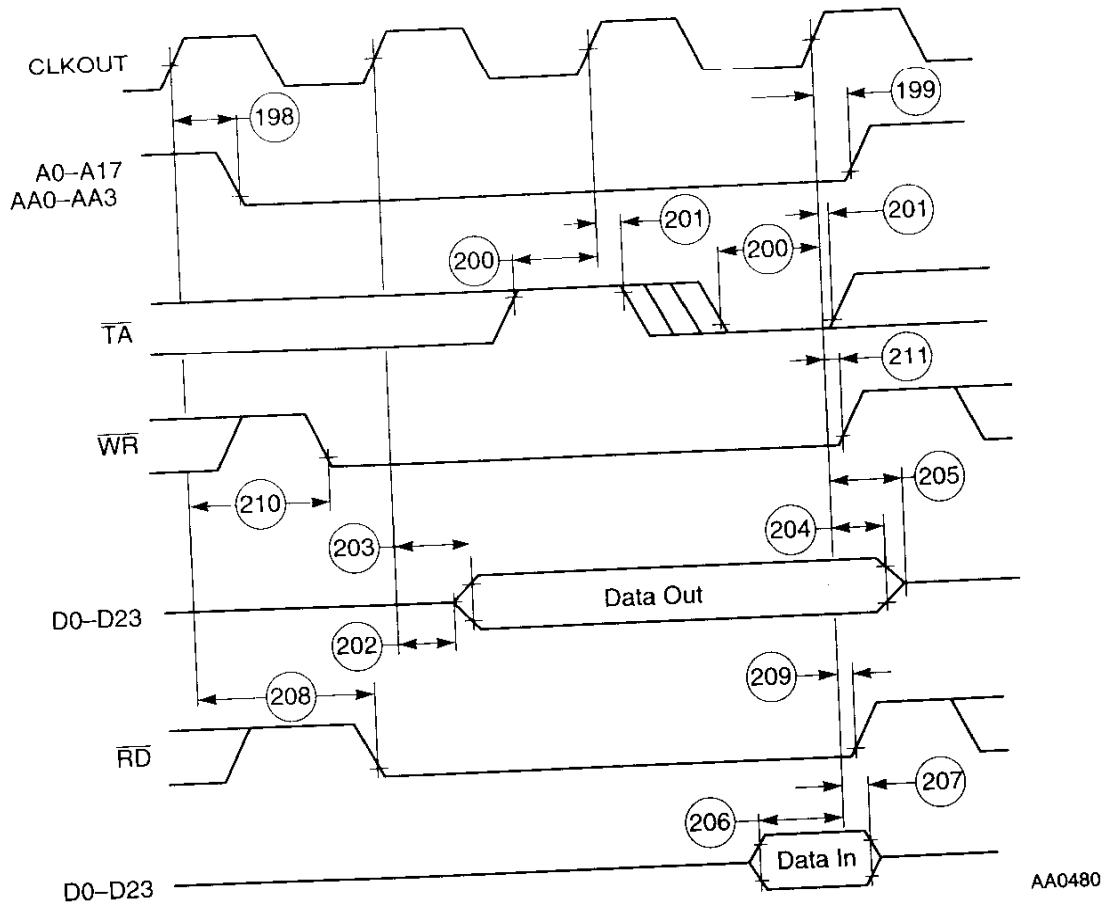

Figure 2-22 Synchronous Bus Timings SRAM 2 WS ( $\bar{T}A$  Controlled)

Arbitration Timings

Table 2-18 Arbitration Bus Timings<sup>1</sup>

No.	Characteristics	Expression	66 MHz		80 MHz		100 MHz		Unit
			Min	Max	Min	Max	Min	Max	
212	CLKOUT high to $\overline{BR}$ assertion/ deassertion <sup>2</sup>		1.0	5.0	1.0	4.5	1.0	4.0	ns
213	$\overline{BG}$ asserted/deasserted to CLKOUT high (setup)		6.0	—	5.0	—	4.0	—	ns
214	CLKOUT high to $\overline{BG}$ deasserted/ asserted (hold)		0.0	—	0.0	—	0.0	—	ns
215	$\overline{BB}$ deassertion to CLKOUT high (input setup)		6.0	—	5.0	—	4.0	—	ns
216	CLKOUT high to $\overline{BB}$ assertion (input hold)		0.0	—	0.0	—	0.0	—	ns
217	CLKOUT high to $\overline{BB}$ assertion (output)		1.0	5.0	1.0	4.5	1.0	4.0	ns
218	CLKOUT high to $\overline{BB}$ deassertion (output)		1.0	5.0	1.0	4.5	1.0	4.0	ns
219	$\overline{BB}$ high to $\overline{BB}$ high impedance (output)		—	6.8	—	5.6	—	4.5	ns
220	CLKOUT high to address and controls active	$0.25 \times T_C$	3.8	—	3.1	—	2.5	—	ns
221	CLKOUT high to address and controls high impedance	66 MHz: $0.25 \times T_C + 1.0$	—	4.8	—	—	—	—	ns
		80 MHz: $0.25 \times T_C + 0.5$	—	—	—	3.6	—	—	ns
		100 MHz: $0.25 \times T_C$	—	—	—	—	—	2.5	ns
222	CLKOUT high to AA active	$0.25 \times T_C$	3.8	—	3.1	—	2.5	—	ns
223	CLKOUT high to AA deassertion	66 MHz: $0.25 \times T_C + 5.0$	4.8	8.8	—	—	—	—	ns
		80 MHz: $0.25 \times T_C + 4.5$	—	—	4.1	7.6	—	—	ns
		100 MHz: $0.25 \times T_C + 4.0$	—	—	—	—	3.2	6.5	ns
224	CLKOUT high to AA high impedance	66 MHz: $0.75 \times T_C + 1.0$	—	12.4	—	—	—	—	ns
		80 MHz: $0.75 \times T_C + 0.5$	—	—	—	9.9	—	—	ns
		100 MHz: $0.75 \times T_C$	—	—	—	—	—	7.5	ns

Notes: 1. The asynchronous delays specified in the expressions are valid for DSP56302A.  
 2. T212 is valid for Address Trace mode when the ATE bit in the OMR is set. BR is deasserted for internal accesses and asserted for external accesses.

Preliminary Information

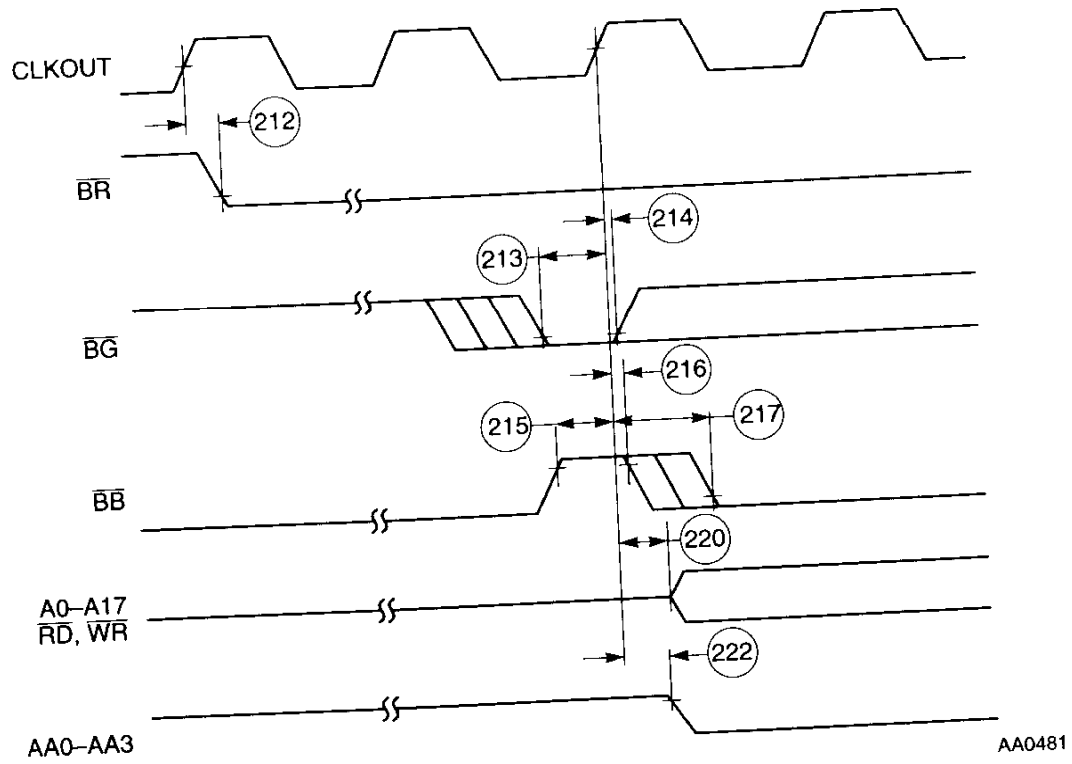

Figure 2-23 Bus Acquisition Timings

Specifications

External Memory Interface (Port A)

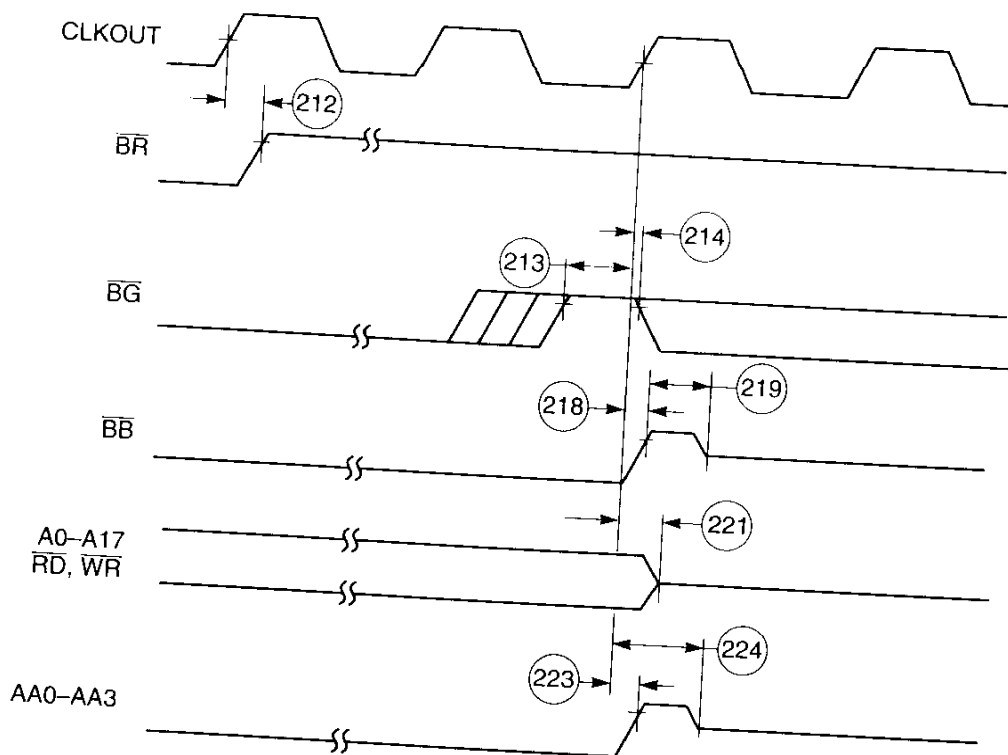
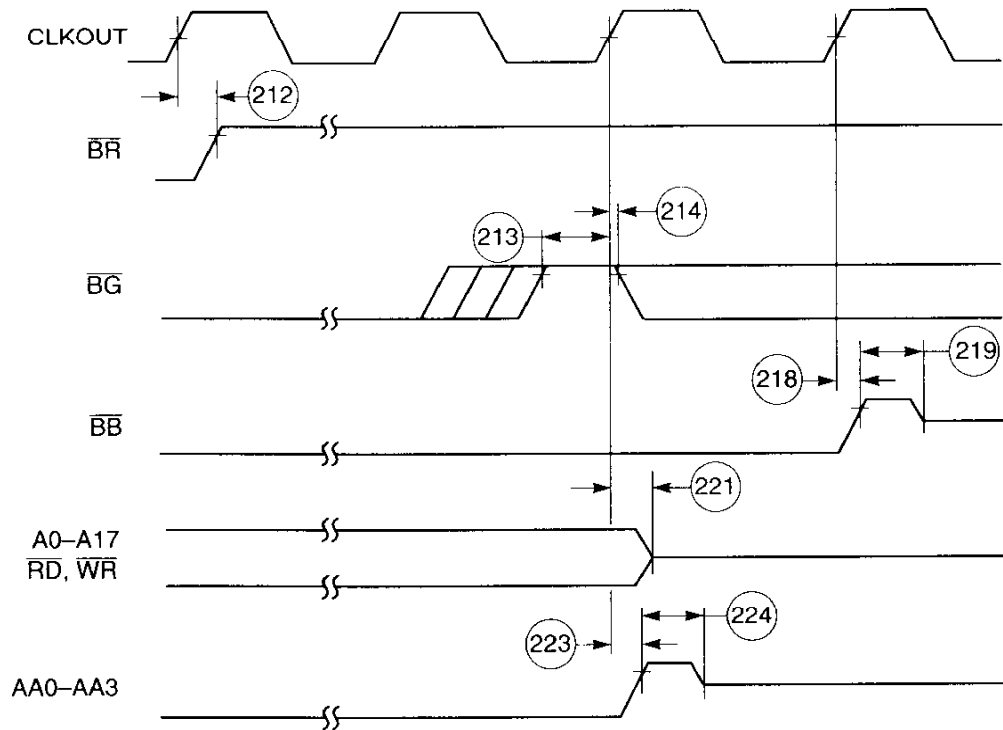

Figure 2-24 Bus Release Timings Case 1 (BRT Bit in OMR Cleared)

AA0482





AA0483

Figure 2-25 Bus Release Timings Case 2 (BRT Bit in OMR Set)

Specifications

Host Interface Timing

HOST INTERFACE TIMING

Table 2-19 Host Interface Timing<sup>1,2</sup>

No.	Characteristic <sup>10</sup>	Expression	66 MHz		80 MHz		100 MHz		Unit
			Min	Max	Min	Max	Min	Max	
317	Read data strobe assertion width <sup>5</sup> $\overline{\text{HACK}}$ assertion width	66 MHz: $T_C + 15.0$	30.2	—	—	—	—	—	ns
		80 MHz: $T_C + 12.4$	—	—	24.9	—	—	—	ns
		100 MHz: $T_C + 9.0$	—	—	—	—	19.9	—	ns
318	Read data strobe deassertion width <sup>5</sup> $\overline{\text{HACK}}$ deassertion width		15.0	—	12.4	—	9.9	—	ns
319	Read data strobe deassertion width <sup>5</sup> after "Last Data Register" reads <sup>8,11</sup> , or between two consecutive CVR, ICR, or ISR reads <sup>3</sup> $\overline{\text{HACK}}$ deassertion width after "Last Data Register" reads <sup>8,11</sup>	66 MHz: $2.5 \times T_C + 10.0$	47.9	—	—	—	—	—	ns
		80 MHz: $2.5 \times T_C + 8.3$	—	—	39.5	—	—	—	ns
		100 MHz: $2.5 \times T_C + 6.6$	—	—	—	—	33.6	—	ns
320	Write data strobe assertion width <sup>6</sup>		20.0	—	16.5	—	13.2	—	ns
321	Write data strobe deassertion width <sup>6</sup>	66 MHz: $2.5 \times T_C + 10.0$	47.9	—	—	—	—	—	ns
		80 MHz: $2.5 \times T_C + 8.3$	—	—	39.5	—	—	—	ns
		100 MHz: $2.5 \times T_C + 6.6$	—	—	—	—	33.6	—	ns
322	$\overline{\text{HAS}}$ assertion width		15.0	—	12.4	—	9.9	—	ns
323	$\overline{\text{HAS}}$ deassertion to data strobe assertion <sup>4</sup>		0.0	—	0.0	—	0.0	—	ns
324	Host data input setup time before write data strobe deassertion <sup>6</sup>		15.0	—	12.4	—	9.9	—	ns
325	Host data input hold time after write data strobe deassertion <sup>6</sup>		5.0	—	4.1	—	3.3	—	ns
326	Read data strobe assertion to output data active from high impedance <sup>5</sup>		5.0	—	4.1	—	3.3	—	ns
	$\overline{\text{HACK}}$ assertion to output data active from high impedance								
327	Read data strobe assertion to output data valid <sup>5</sup> $\overline{\text{HACK}}$ assertion to output data valid		—	30.0	—	26.68	—	23.54	ns

Preliminary Information

Table 2-19 Host Interface Timing<sup>1,2</sup> (Continued)

No.	Characteristic <sup>10</sup>	Expression	66 MHz		80 MHz		100 MHz		Unit
			Min	Max	Min	Max	Min	Max	
328	Read data strobe deassertion to output data high impedance <sup>5</sup> $\overline{\text{HACK}}$ deassertion to output data high impedance		—	15.0	—	12.4	—	9.9	ns
329	Output data hold time after read data strobe deassertion <sup>5</sup> Output data hold time after $\overline{\text{HACK}}$ deassertion		5.0	—	4.1	—	4.1	—	ns
330	$\overline{\text{HCS}}$ assertion to read data strobe deassertion <sup>5</sup>	66 MHz: $T_C + 15.0$	30.2	—	—	—	—	—	ns
		80 MHz: $T_C + 12.4$	—	—	24.9	—	—	—	ns
		100 MHz: $T_C + 9.9$	—	—	—	—	19.9	—	ns
331	$\overline{\text{HCS}}$ assertion to write data strobe deassertion <sup>6</sup>		15.0	—	12.4	—	9.9	—	ns
332	$\overline{\text{HCS}}$ assertion to output data valid		—	25.0	—	20.6	—	16.5	ns
333	$\overline{\text{HCS}}$ hold time after data strobe deassertion <sup>4</sup>		0.0	—	0.0	—	0.0	—	ns
334	Address (AD7–AD0) setup time before $\overline{\text{HAS}}$ deassertion (HMUX=1)		7.0	—	5.8	—	4.7	—	ns
335	Address (AD7–AD0) hold time after $\overline{\text{HAS}}$ deassertion (HMUX=1)		5.0	—	4.1	—	3.3	—	ns
336	A10–A8 (HMUX=1), A2–A0 (HMUX=0), HR/ $\overline{\text{W}}$ setup time before data strobe assertion <sup>4</sup> • Read • Write		0	—	0	—	0	—	ns
			7.0	—	5.8	—	4.7	—	ns
337	A10–A8 (HMUX=1), A2–A0 (HMUX=0), HR/ $\overline{\text{W}}$ hold time after data strobe deassertion <sup>4</sup>		5.0	—	4.1	—	3.3	—	ns
338	Delay from read data strobe deassertion to host request assertion for “Last Data Register” read <sup>5,7,8</sup>	66 MHz: $2 \times T_C + 25.0$	55.3	—	—	—	—	—	ns
		80 MHz: $2 \times T_C + 20.6$	—	—	45.6	—	—	—	ns
		100 MHz: $2 \times T_C + 20.6$	—	—	—	—	36.5	—	ns

## Preliminary Information

**Specifications**

**Host Interface Timing**

**Table 2-19 Host Interface Timing<sup>1,2</sup> (Continued)**

No.	Characteristic <sup>10</sup>	Expression	66 MHz		80 MHz		100 MHz		Unit
			Min	Max	Min	Max	Min	Max	
339	Delay from write data strobe deassertion to host request assertion for "Last Data Register" write <sup>6,7,8</sup>	<b>66 MHz:</b> $1.5 \times T_C + 25.0$	47.7	—	—	—	—	—	ns
		<b>80 MHz:</b> $1.5 \times T_C + 20.6$	—	—	39.4	—	—	—	ns
		<b>100 MHz:</b> $1.5 \times T_C + 16.5$	—	—	—	—	31.5	—	ns
340	Delay from data strobe assertion to host request deassertion for "Last Data Register" read or write (HROD=0) <sup>4,7,8</sup>		—	25.0	—	22.55	—	20.24	ns
341	Delay from data strobe assertion to host request deassertion for "Last Data Register" read or write (HROD=1, open drain host request) <sup>4,7,8,9</sup>		—	300.0	—	300.0	—	300.0	ns

Notes:

1. See **Host Port Usage Considerations** on page 1-11.
2. In the timing diagrams below, the controls pins are drawn as active low. The pin polarity is programmable.
3. This timing is applicable only if two consecutive reads from one of these registers are executed.
4. The data strobe is Host Read (HRD) or Host Write (HWR) in the Dual Data Strobe mode and Host Data Strobe (HDS) in the Single Data Strobe mode.
5. The read data strobe is HRD in the Dual Data Strobe mode and HDS in the Single Data Strobe mode.
6. The write data strobe is HWR in the Dual Data Strobe mode and HDS in the Single Data Strobe mode.
7. The host request is HREQ in the Single Host Request mode and HRRQ and HTRQ in the Double Host Request mode.
8. The "Last Data Register" is the register at address \$7, which is the last location to be read or written in data transfers. This is RXL/TXL in the Little Endian mode (HBE = 0), or RXH/TXH in the Big Endian mode (HBE = 1).
9. In this calculation, the host request signal is pulled up by a 4.7 kΩ resistor in the Open-drain mode.
10.  $V_{CC} = 3.3 \text{ V} \pm 0.3 \text{ V}$ ;  $T_J = -40^\circ\text{C}$  to  $+100^\circ\text{C}$ ,  $C_L = 50 \text{ pF}$
11. This timing is applicable only if a read from the "Last Data Register" is followed by a read from the RXL, RXM, or RXH registers without first polling RXDF or HREQ bits, or waiting for the assertion of the HREQ signal.

**Preliminary Information**

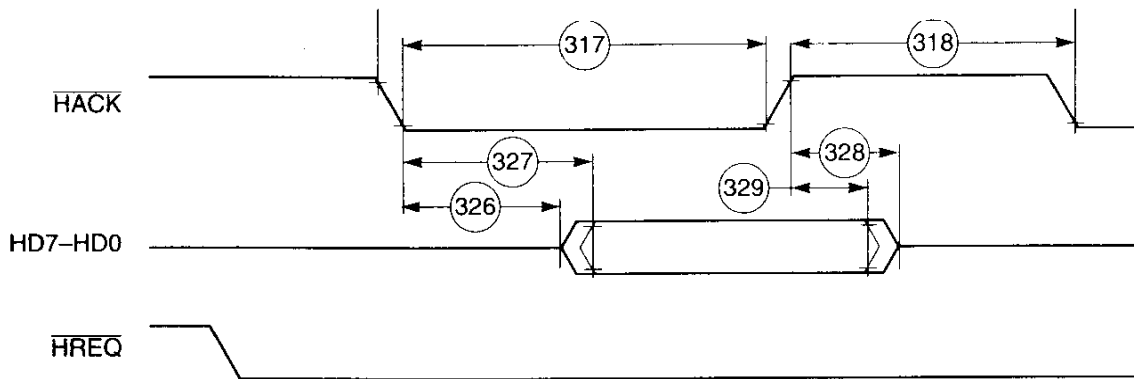

AA1105

Figure 2-26 Host Interrupt Vector Register (IVR) Read Timing Diagram

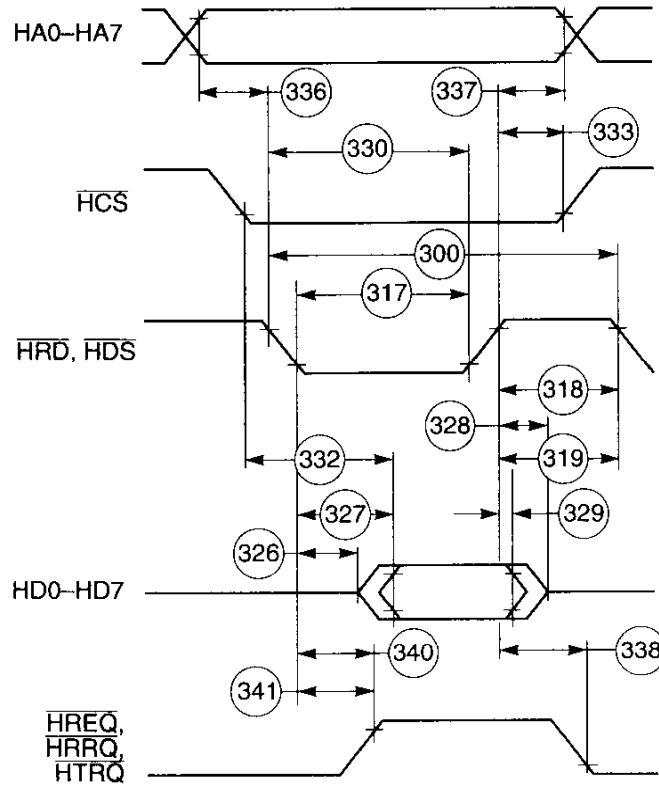

AA0484

Figure 2-27 Read Timing Diagram, Non-Multiplexed Bus

Preliminary Information

Specifications

Host Interface Timing

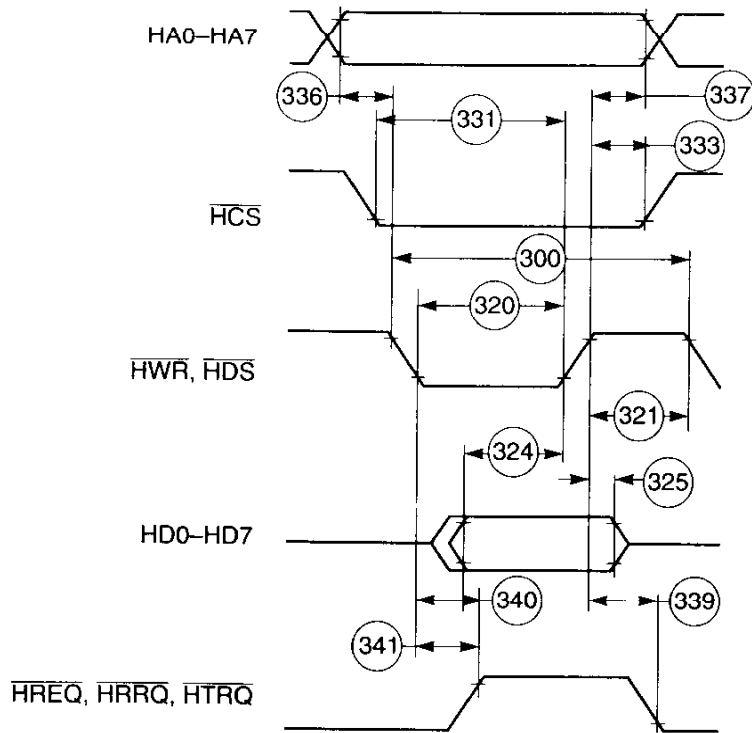

AA0485

Figure 2-28 Write Timing Diagram, Non-Multiplexed Bus

Preliminary Information

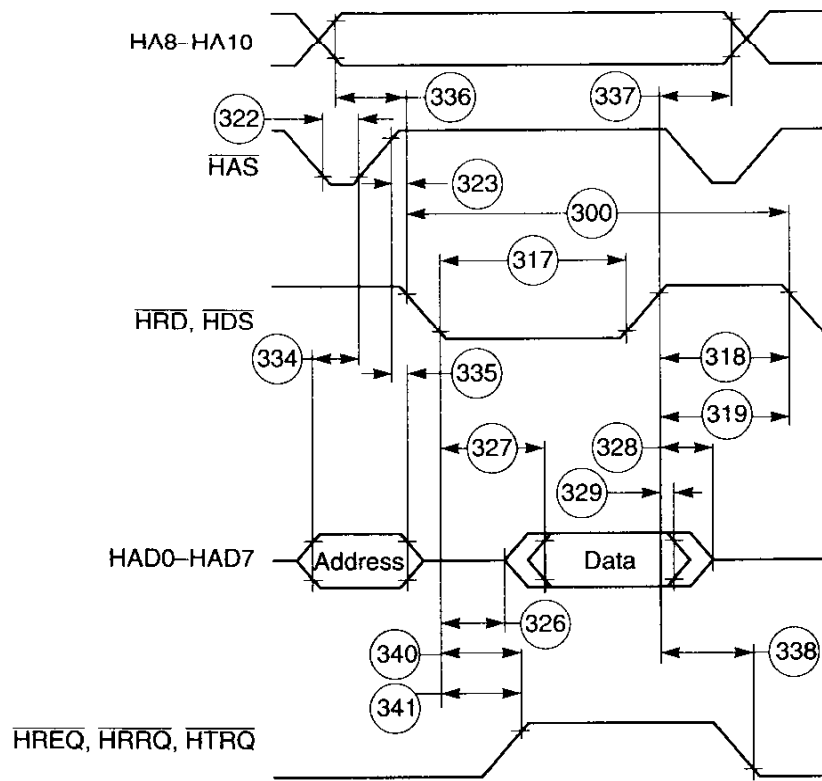

AA0486

Figure 2-29 Read Timing Diagram, Multiplexed Bus

Specifications

Host Interface Timing

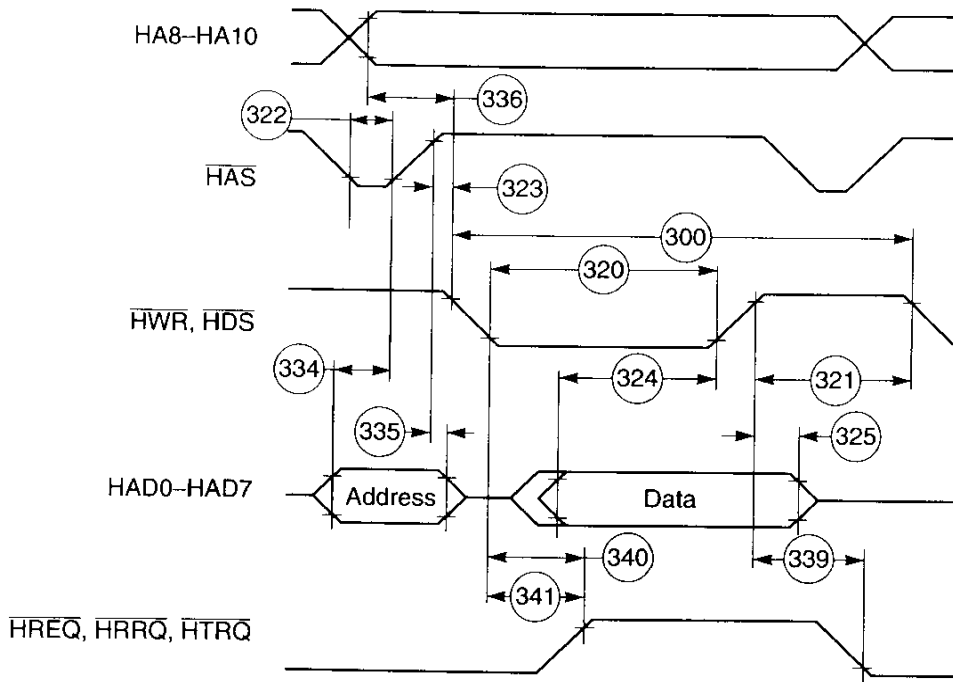

AA0487

Figure 2-30 Write Timing Diagram, Multiplexed Bus



## SCI TIMING

Table 2-20 SCI Timing

No.	Characteristics <sup>1</sup>	Symbol	Expression	66 MHz		80 MHz		100 MHz		Unit
				Min	Max	Min	Max	Min	Max	
400	Synchronous clock cycle	$t_{SCC}^2$	$8 \times T_C$	121.0	—	100.0	—	80.0	—	ns
401	Clock low period		$t_{SCC}/2 - 10.0$	50.5	—	40.0	—	30.0	—	ns
402	Clock high period		$t_{SCC}/2 - 10.0$	50.5	—	40.0	—	30.0	—	ns
403	Output data setup to clock falling edge (internal clock)		$t_{SCC}/4 + 0.5 \times T_C - 17.0$	20.5	—	14.3	—	8.0	—	ns
404	Output data hold after clock rising edge (internal clock)		$t_{SCC}/4 - 0.5 \times T_C$	22.5	—	18.8	—	15.0	—	ns
405	Input data setup time before clock rising edge (internal clock)		$t_{SCC}/4 + 0.5 \times T_C + 25.0$	63.0	—	56.3	—	50.0	—	ns
406	Input data not valid before clock rising edge (internal clock)		$t_{SCC}/4 + 0.5 \times T_C - 5.5$	—	32.0	—	25.8	—	19.5	ns
407	Clock falling edge to output data valid (external clock)			—	32.0	—	32.0	—	32.0	ns
408	Output data hold after clock rising edge (external clock)		$T_C + 8.0$	23.0	—	20.5	—	18.0	—	ns
409	Input data setup time before clock rising edge (external clock)			0.0	—	0.0	—	0.0	—	ns
410	Input data hold time after clock rising edge (external clock)			9.0	—	9.0	—	9.0	—	ns
411	Asynchronous clock cycle	$t_{ACC}^3$	$64 \times T_C$	969.7	—	800.0	—	640.0	—	ns
412	Clock low period		$t_{ACC}/2 - 10.0$	474.8	—	390.0	—	310.0	—	ns
413	Clock high period		$t_{ACC}/2 - 10.0$	474.8	—	390.0	—	310.0	—	ns

## Preliminary Information

## Specifications

### SCI Timing

Table 2-20 SCI Timing (Continued)

No.	Characteristics <sup>1</sup>	Symbol	Expression	66 MHz		80 MHz		100 MHz		Unit
				Min	Max	Min	Max	Min	Max	
414	Output data setup to clock rising edge (internal clock)		$t_{ACC}/2 - 30.0$	458.8	—	370.0	—	290.0	—	ns
415	Output data hold after clock rising edge (internal clock)		$t_{ACC}/2 - 30.0$	458.8	—	370.0	—	290.0	—	ns

Notes: 1.  $V_{CC} = 3.3 \text{ V} \pm 0.3 \text{ V}$ ;  $T_J = -40^\circ\text{C}$  to  $+100^\circ\text{C}$ ,  $C_L = 50 \text{ pF}$   
 2.  $t_{SCC}$  = synchronous clock cycle time (For internal clock,  $t_{SCC}$  is determined by the SCI clock control register and  $T_C$ )  
 3.  $t_{ACC}$  = asynchronous clock cycle time; value given for 1X Clock mode (For internal clock,  $t_{ACC}$  is determined by the SCI clock control register and  $T_C$ )

### Preliminary Information

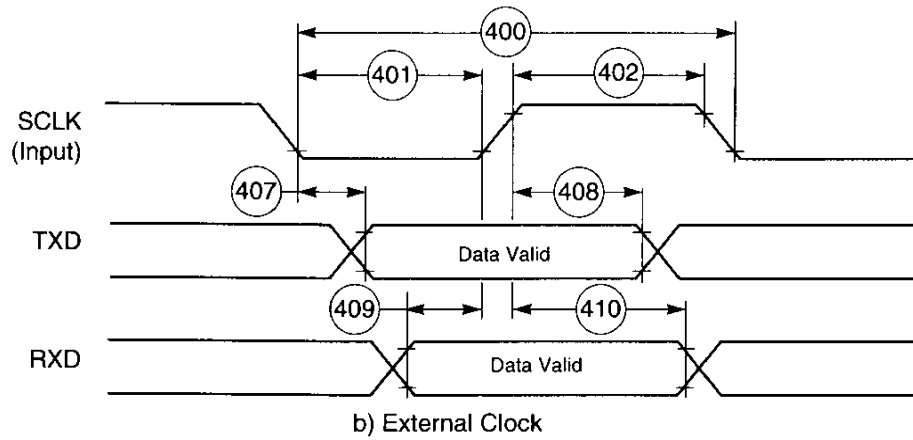
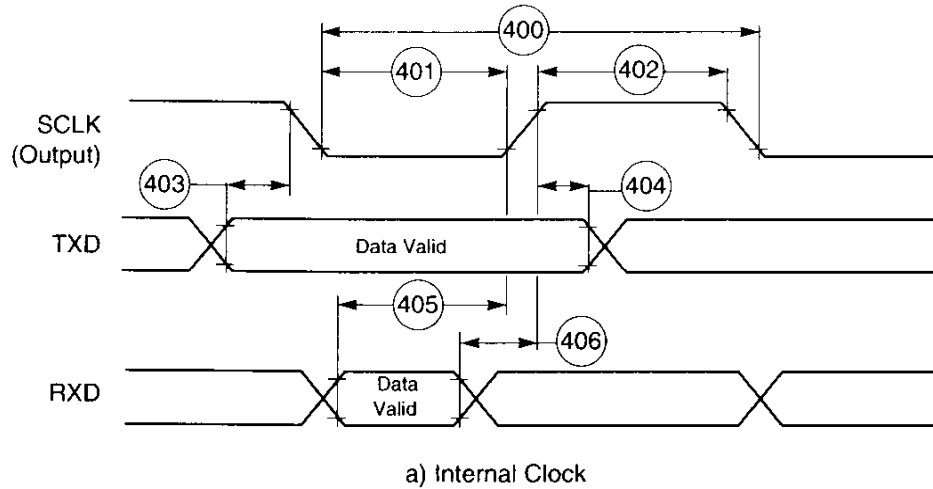

AA0488

Figure 2-31 SCI Synchronous Mode Timing

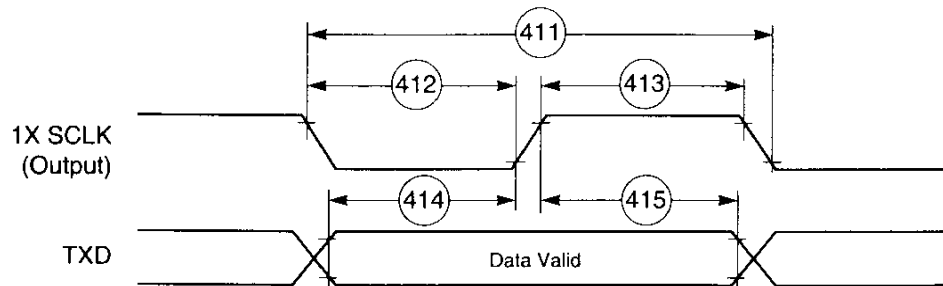

AA0489

Figure 2-32 SCI Asynchronous Mode Timing

Preliminary Information

Specifications

ESSI0/ESSI1 Timing

ESSI0/ESSI1 TIMING

Table 2-21 ESSI Timings

No.	Characteristics <sup>4, 6, 7</sup>	Symbol	Expression	66 MHz		80 MHz		100 MHz		Condition <sup>5</sup>	Unit
				Min	Max	Min	Max	Min	Max		
430	Clock cycle <sup>1</sup>	$t_{SSICC}$	$4 \times T_C$ $3 \times T_C$	60.6 45.5	— —	50.0 37.5	— —	40.0 30.0	— —	i ck x ck	ns
431	Clock high period • For internal clock • For external clock		$2 \times T_C - 10.0$ $1.5 \times T_C$	20.3 22.7	— —	15.0 18.8	— —	10.0 15.0	— —		ns ns
432	Clock low period • For internal clock • For external clock		$2 \times T_C - 10.0$ $1.5 \times T_C$	20.3 22.7	— —	15.0 18.8	— —	10.0 15.0	— —		ns ns
433	RXC rising edge to FSR out (bl) high			— —	37.0 22.0	— —	37.0 22.0	— —	37.0 22.0	x ck i ck a	ns
434	RXC rising edge to FSR out (bl) low			— —	37.0 22.0	— —	37.0 22.0	— —	37.0 22.0	x ck i ck a	ns
435	RXC rising edge to FSR out (wr) high <sup>2</sup>			— —	39.0 24.0	— —	39.0 24.0	— —	39.0 24.0	x ck i ck a	ns
436	RXC rising edge to FSR out (wr) low <sup>2</sup>			— —	39.0 24.0	— —	39.0 24.0	— —	39.0 24.0	x ck i ck a	ns
437	RXC rising edge to FSR out (wl) high			— —	36.0 21.0	— —	36.0 21.0	— —	36.0 21.0	x ck i ck a	ns
438	RXC rising edge to FSR out (wl) low			— —	37.0 22.0	— —	37.0 22.0	— —	37.0 22.0	x ck i ck a	ns
439	Data in setup time before RXC (SCK in Synchronous mode) falling edge			0.0 19.0	— —	0.0 19.0	— —	0.0 19.0	— —	x ck i ck	ns
440	Data in hold time after RXC falling edge			5.0 3.0	— —	5.0 3.0	— —	5.0 3.0	— —	x ck i ck	ns
441	FSR input (bl, wr) high before RXC falling edge <sup>2</sup>			23.0 1.0	— —	23.0 1.0	— —	23.0 1.0	— —	x ck i ck a	ns
442	FSR input (wl) high before RXC falling edge			23.0 1.0	— —	23.0 1.0	— —	23.0 1.0	— —	x ck i ck a	ns
443	FSR input hold time after RXC falling edge			3.0 0.0	— —	3.0 0.0	— —	3.0 0.0	— —	x ck i ck a	ns
444	Flags input setup before RXC falling edge			0.0 19.0	— —	0.0 19.0	— —	0.0 19.0	— —	x ck i ck s	ns

Preliminary Information

Table 2-21 ESSI Timings (Continued)

No.	Characteristics <sup>4,6,7</sup>	Symbol	Expression	66 MHz		80 MHz		100 MHz		Condition <sup>5</sup>	Unit
				Min	Max	Min	Max	Min	Max		
445	Flags input hold time after RXC falling edge			6.0 0.0	— —	6.0 0.0	— —	6.0 0.0	— —	x ck i ck s	ns
446	TXC rising edge to FST out (bl) high			— —	29.0 15.0	— —	29.0 15.0	— —	29.0 15.0	x ck i ck	ns
447	TXC rising edge to FST out (bl) low			— —	31.0 17.0	— —	31.0 17.0	— —	31.0 17.0	x ck i ck	ns
448	TXC rising edge to FST out (wr) high <sup>2</sup>			— —	31.0 17.0	— —	31.0 17.0	— —	31.0 17.0	x ck i ck	ns
449	TXC rising edge to FST out (wr) low <sup>2</sup>			— —	33.0 19.0	— —	33.0 19.0	— —	33.0 19.0	x ck i ck	ns
450	TXC rising edge to FST out (wl) high			— —	30.0 16.0	— —	30.0 16.0	— —	30.0 16.0	x ck i ck	ns
451	TXC rising edge to FST out (wl) low			— —	31.0 17.0	— —	31.0 17.0	— —	31.0 17.0	x ck i ck	ns
452	TXC rising edge to data out enable from high impedance			— —	31.0 17.0	— —	31.0 17.0	— —	31.0 17.0	x ck i ck	ns
453	TXC rising edge to Transmitter #0 drive enable assertion			— —	34.0 20.0	— —	34.0 20.0	— —	34.0 20.0	x ck i ck	ns
454	TXC rising edge to data out valid		$35 + 0.5 \times T_C$ 21.0	— —	42.6 21.0	— —	41.3 21.0	— —	40.0 21.0	x ck i ck	ns
455	TXC rising edge to data out high impedance <sup>3</sup>			— —	31.0 16.0	— —	31.0 16.0	— —	31.0 16.0	x ck i ck	ns
456	TXC rising edge to Transmitter #0 drive enable deassertion <sup>3</sup>			— —	34.0 20.0	— —	34.0 20.0	— —	34.0 20.0	x ck i ck	ns
457	FST input (bl, wr) setup time before TXC falling edge <sup>2</sup>			2.0 21.0	— —	2.0 21.0	— —	2.0 21.0	— —	x ck i ck	ns
458	FST input (wl) to data out enable from high impedance			—	27.0	—	27.0	—	27.0	—	ns
459	FST input (wl) to Transmitter #0 drive enable assertion			—	31.0	—	31.0	—	31.0	—	ns

## Preliminary Information

## Specifications

### ESSIO/ESSI1 Timing

Table 2-21 ESSI Timings (Continued)

No.	Characteristics <sup>4, 6, 7</sup>	Symbol	Expression	66 MHz		80 MHz		100 MHz		Condition <sup>5</sup>	Unit
				Min	Max	Min	Max	Min	Max		
460	FST input (wl) setup time before TXC falling edge			2.0 21.0	— —	2.0 21.0	— —	2.0 21.0	— —	x ck i ck	ns
461	FST input hold time after TXC falling edge			4.0 0.0	— —	4.0 0.0	— —	4.0 0.0	— —	x ck i ck	ns
462	Flag output valid after TXC rising edge			— —	32.0 18.0	— —	32.0 18.0	— —	32.0 18.0	x ck i ck	ns

- Notes:
- For the internal clock, the external clock cycle is defined by  $I_{cyc}$  and the ESSI control register.
  - The word-relative frame sync signal waveform relative to the clock operates in the same manner as the bit-length frame sync signal waveform, but spreads from one serial clock before first bit clock (same as Bit Length Frame Sync signal), until the one before last bit clock of the first word in frame.
  - Periodically sampled and not 100% tested
  - $V_{CC} = 3.3 V \pm 0.3 V$ ;  $T_j = -40^\circ C$  to  $+100^\circ C$ ,  $C_L = 50 pF$
  - TXC (SCK Pin) = Transmit Clock  
RXC (SC0 or SCK Pin) = Receive Clock  
FST (SC2 Pin) = Transmit Frame Sync  
FSR (SC1 or SC2 Pin) Receive Frame Sync
  - i ck = Internal Clock  
x ck = External Clock  
i ck a = Internal Clock, Asynchronous Mode  
(Asynchronous implies that TXC and RXC are two different clocks)  
i ck s = Internal Clock, Synchronous Mode  
(Synchronous implies that TXC and RXC are the same clock)
  - bl = bit length  
wl = word length  
wr = word length relative

## Preliminary Information

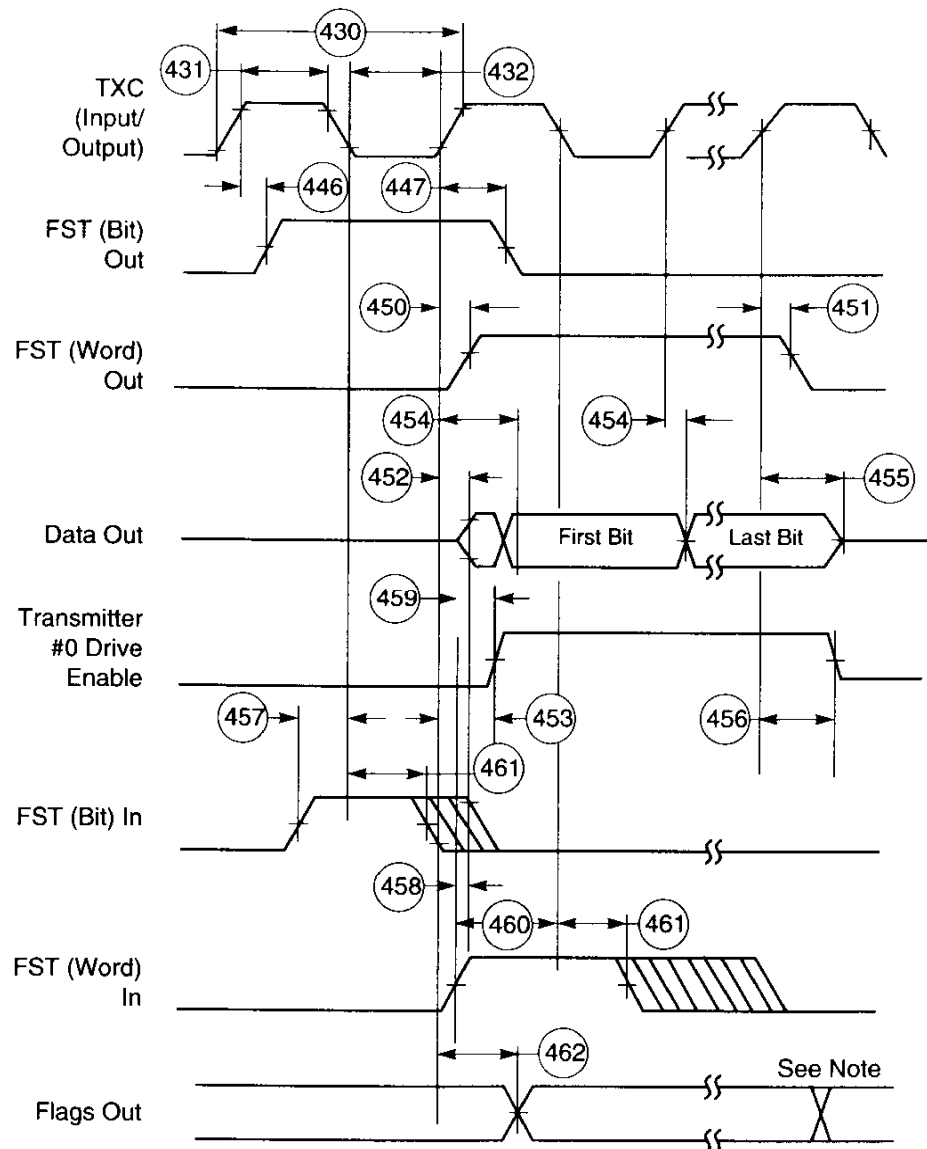

Note: In Network mode, output flag transitions can occur at the start of each time slot within the frame. In Normal mode, the output flag state is asserted for the entire frame period.

AA0490

Figure 2-33 ESSI Transmitter Timing

Specifications

ESSI0/ESSI1 Timing

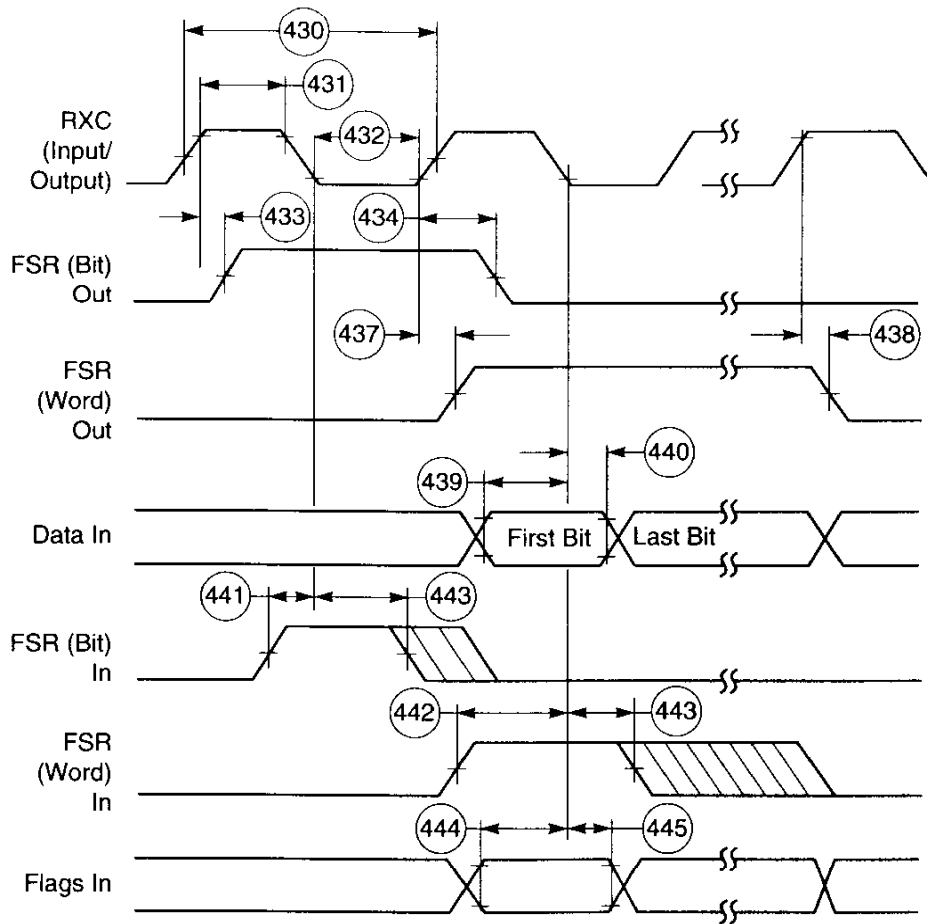

Figure 2-34 ESSI Receiver Timing

Preliminary Information



## TIMER TIMING

Table 2-22 Timer Timing

No.	Characteristics	Expression	66 MHz		80 MHz		100 MHz		Unit
			Min	Max	Min	Max	Min	Max	
480	TIO Low	$2 \times T_C + 2.0$	32.5	—	27.0	—	22.0	—	ns
481	TIO High	$2 \times T_C + 2.0$	32.5	—	27.0	—	22.0	—	ns
482	Timer setup time from TIO (Input) assertion to CLKOUT rising edge		9.0	15.15	9.0	12.5	9.0	10.0	ns
483	Synchronous timer delay time from CLKOUT rising edge to the external memory access address out valid caused by first interrupt instruction execution	$10.25 \times T_C + 1.0$	156.0	—	129.1	—	103.5	—	ns
484	CLKOUT rising edge to TIO (Output) assertion • Minimum • Maximum	$0.5 \times T_C + 3.5$	11.1	—	9.8	—	8.5	—	ns
		$0.5 \times T_C + 19.8$	—	28.1	—	26.1	—	24.8	ns
485	CLKOUT rising edge to TIO (Output) deassertion • Minimum • Maximum	$60.5 \times T_C + 3.5$	11.1	—	9.8	—	8.5	—	ns
		<b>66–80 MHz:</b> $0.5 \times T_C + 19.8$	—	28.1	—	26.1	—	—	ns
		<b>100 MHz:</b> $0.5 \times T_C + 19.0$	—	—	—	—	—	24.8	ns

Note:  $V_{CC} = 3.3 \text{ V} \pm 0.3 \text{ V}$ ;  $T_J = -40^\circ\text{C}$  to  $+100^\circ\text{C}$ ,  $C_L = 50 \text{ pF}$

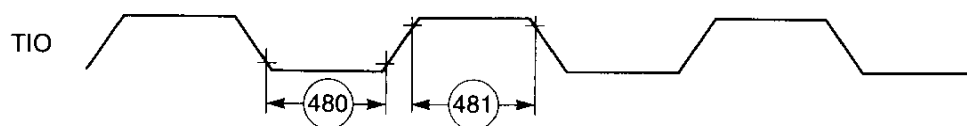

AA0492

Figure 2-35 TIO Timer Event Input Restrictions

## Preliminary Information

# Specifications

## Timer Timing

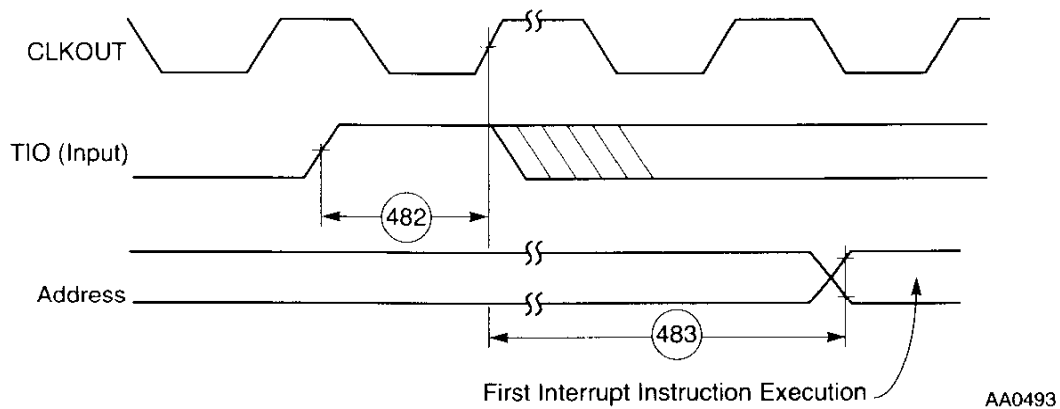

Figure 2-36 Timer Interrupt Generation

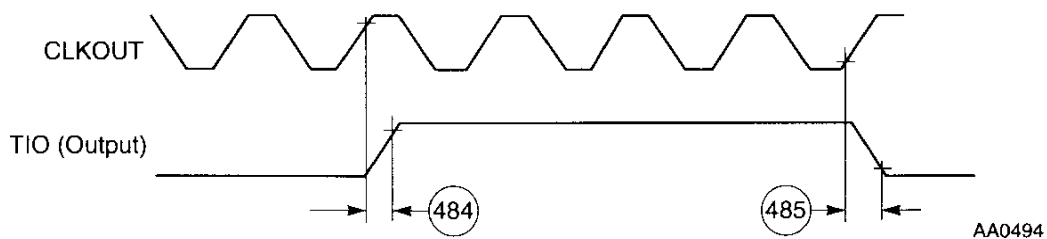

Figure 2-37 External Pulse Generation

## Preliminary Information

## GPIO TIMING

Table 2-23 GPIO Timing

No.	Characteristics	Expression	66 MHz		80 MHz		100 MHz		Unit
			Min	Max	Min	Max	Min	Max	
490	CLKOUT edge to GPIO out valid (GPIO out delay time)		—	31.0	—	31.0	—	31.0	ns
491	CLKOUT edge to GPIO out not valid (GPIO out hold time)		3.0	—	3.0	—	3.0	—	ns
492	GPIO In valid to CLKOUT edge (GPIO in set-up time)		12.0	—	12.0	—	12.0	—	ns
493	CLKOUT edge to GPIO in not valid (GPIO in hold time)		0.0	—	0.0	— <td 0.0	—	ns	
494	Fetch to CLKOUT edge before GPIO change	$6.75 \times T_C$	102.3	—	84.4	—	67.5	—	ns

Note:  $V_{CC} = 3.3 \text{ V} \pm 0.3 \text{ V}$ ;  $T_J = -40^\circ\text{C}$  to  $+100^\circ\text{C}$ ,  $C_L = 50 \text{ pF}$

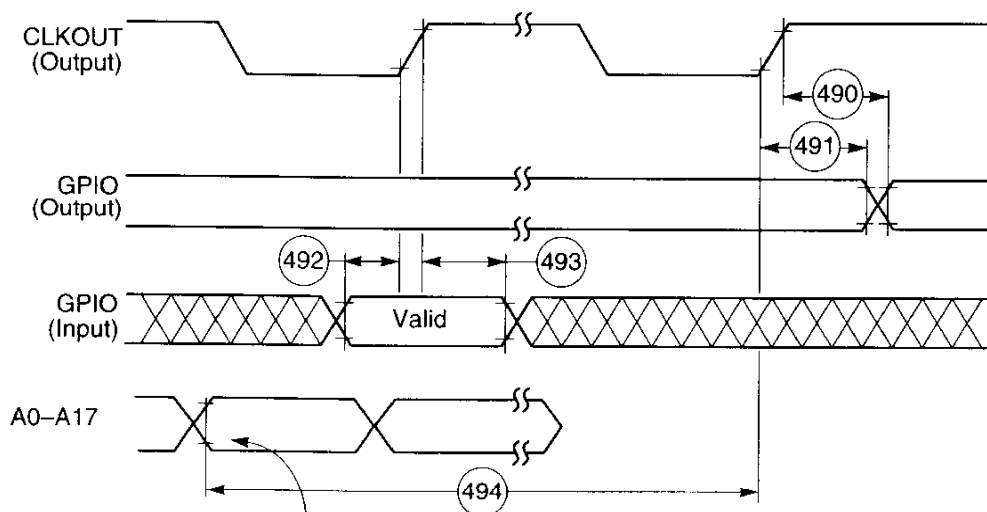

Fetch the instruction MOVE X0,X:(R0); X0 contains the new value of GPIO and R0 contains the address of GPIO data register.

AA0495

Figure 2-38 GPIO Timing

## Preliminary Information

**Specifications**

**JTAG Timing**

**JTAG TIMING**

**Table 2-24 JTAG Timing**

No.	Characteristics	All frequencies		Unit
		Min	Max	
500	TCK frequency of operation ( $1/(T_C \times 3)$ ; maximum 22 MHz)	0.0	22.0	MHz
501	TCK cycle time in Crystal mode	45.0	—	ns
502	TCK clock pulse width measured at 1.5 V	20.0	—	ns
503	TCK rise and fall times	0.0	3.0	ns
504	Boundary scan input data setup time	5.0	—	ns
505	Boundary scan input data hold time	24.0	—	ns
506	TCK low to output data valid	0.0	40.0	ns
507	TCK low to output high impedance	0.0	40.0	ns
508	TMS, TDI data setup time	5.0	—	ns
509	TMS, TDI data hold time	25.0	—	ns
510	TCK low to TDO data valid	0.0	44.0	ns
511	TCK low to TDO high impedance	0.0	44.0	ns
512	$\overline{\text{TRST}}$ assert time	100.0	—	ns
513	$\overline{\text{TRST}}$ setup time to TCK low	40.0	—	ns

Notes: 1.  $V_{CC} = 3.3 \text{ V} \pm 0.3 \text{ V}$ ;  $T_J = -40^\circ\text{C}$  to  $+100^\circ\text{C}$ ,  $C_L = 50 \text{ pF}$   
 2. All timings apply to OnCE module data transfers because it uses the JTAG port as an interface.

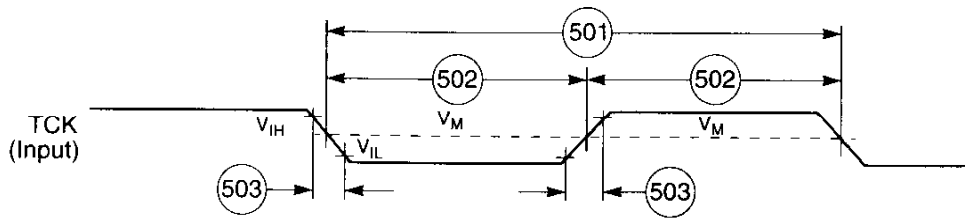

**Figure 2-39 Test Clock Input Timing Diagram**

AA0496

**Preliminary Information**

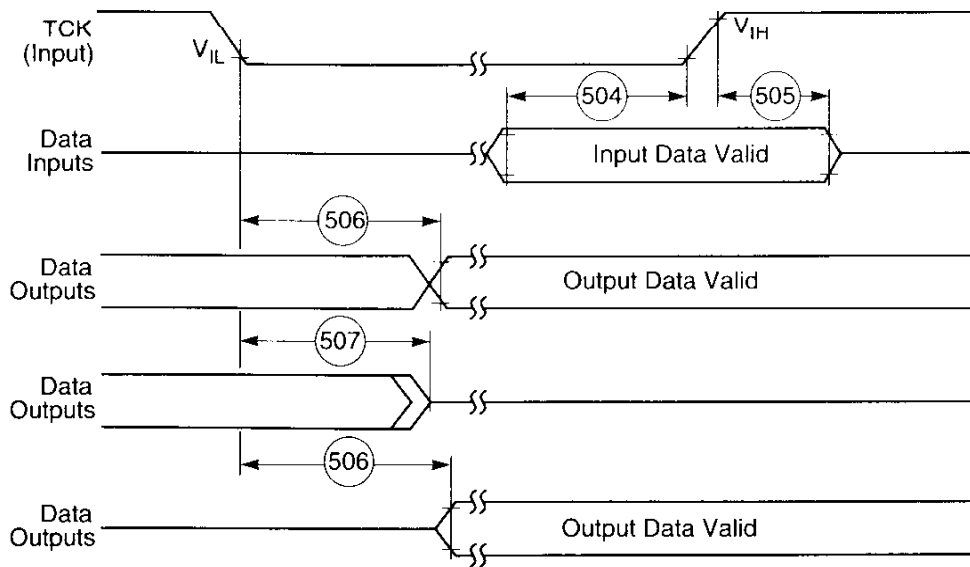

AA0497

Figure 2-40 Boundary Scan (JTAG) Timing Diagram

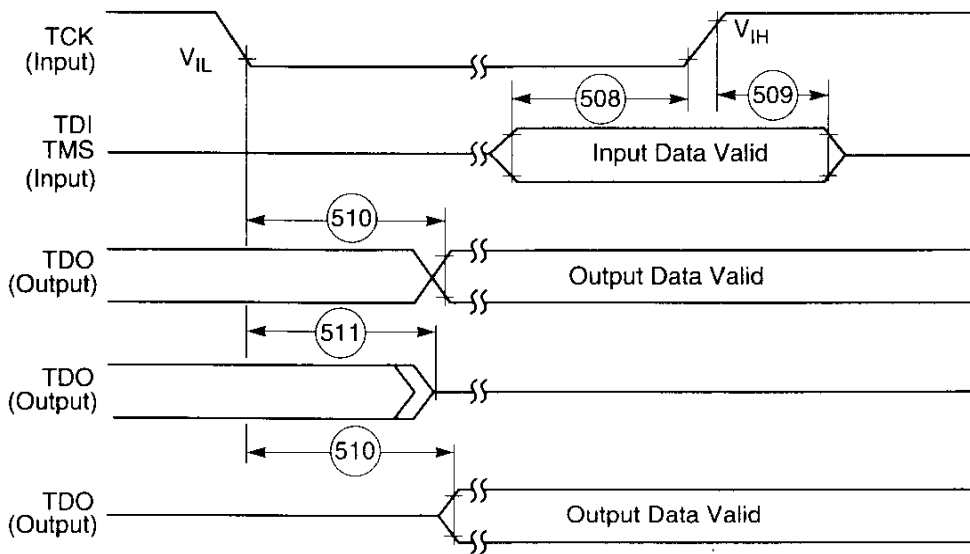

AA0498

Figure 2-41 Test Access Port Timing Diagram

Preliminary Information

## Specifications

### OnCE Module Timing

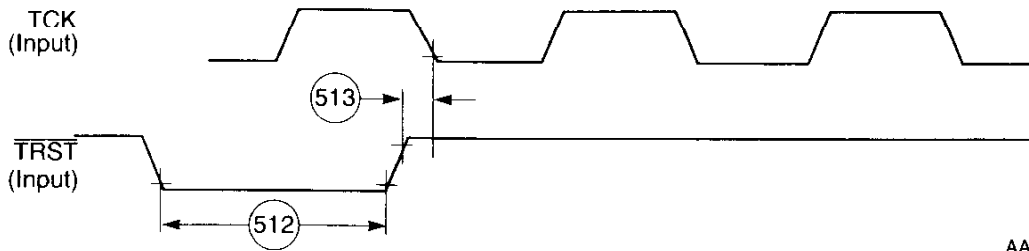

AA0499

Figure 2-42  $\overline{\text{TRST}}$  Timing Diagram

## OnCE MODULE TIMING

Table 2-25 OnCE Module Timing

No.	Characteristics	Expression	66 MHz		80 MHz		100 MHz		Unit
			Min	Max	Min	Max	Min	Max	
500	TCK frequency of operation	$1/(T_C \times 3)$ , max 22.0 MHz	0.0	22.0	0.0	22.0	0.0	22.0	MHz
514	$\overline{\text{DE}}$ assertion time in order to enter Debug mode	$1.5 \times T_C + 10.0$	32.7	—	28.8	—	25.0	—	ns
515	Response time when DSP56302A is executing NOP instructions from internal memory	$5.5 \times T_C + 30.0$	—	113.3	—	98.8	—	85.0	ns
516	Debug acknowledge assertion time	$3 \times T_C + 10.0$	55.5	—	47.5	—	40.0	—	ns

Note:  $V_{CC} = 3.3 \text{ V} \pm 0.3 \text{ V}$ ;  $T_J = -40^\circ\text{C}$  to  $+100^\circ\text{C}$ ;  $C_L = 50 \text{ pF}$

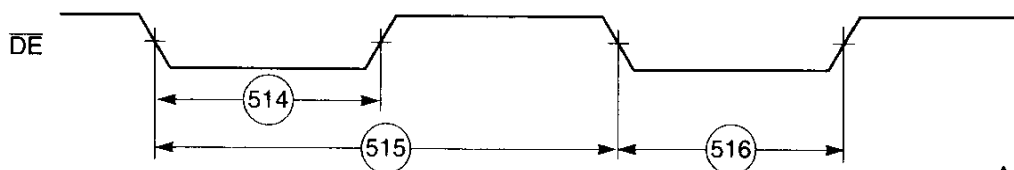

AA0500

Figure 2-43 OnCE—Debug Request



## Preliminary Information

# SECTION 3

## PACKAGING

---

---

### PIN-OUT AND PACKAGE INFORMATION

This sections provides information about the available packages for this product, including diagrams of the package pinouts and tables describing how the signals described in **Section 1** are allocated for each package.

The DSP56302A is available in two package types:

- 144-pin Thin Quad Flat Pack (TQFP)
- 196-pin Plastic Ball Grid Array (PBGA)

Preliminary Information

### TQFP Package Description

Top and bottom views of the TQFP package are shown in **Figure 3-1** and **Figure 3-2** with their pin-outs.

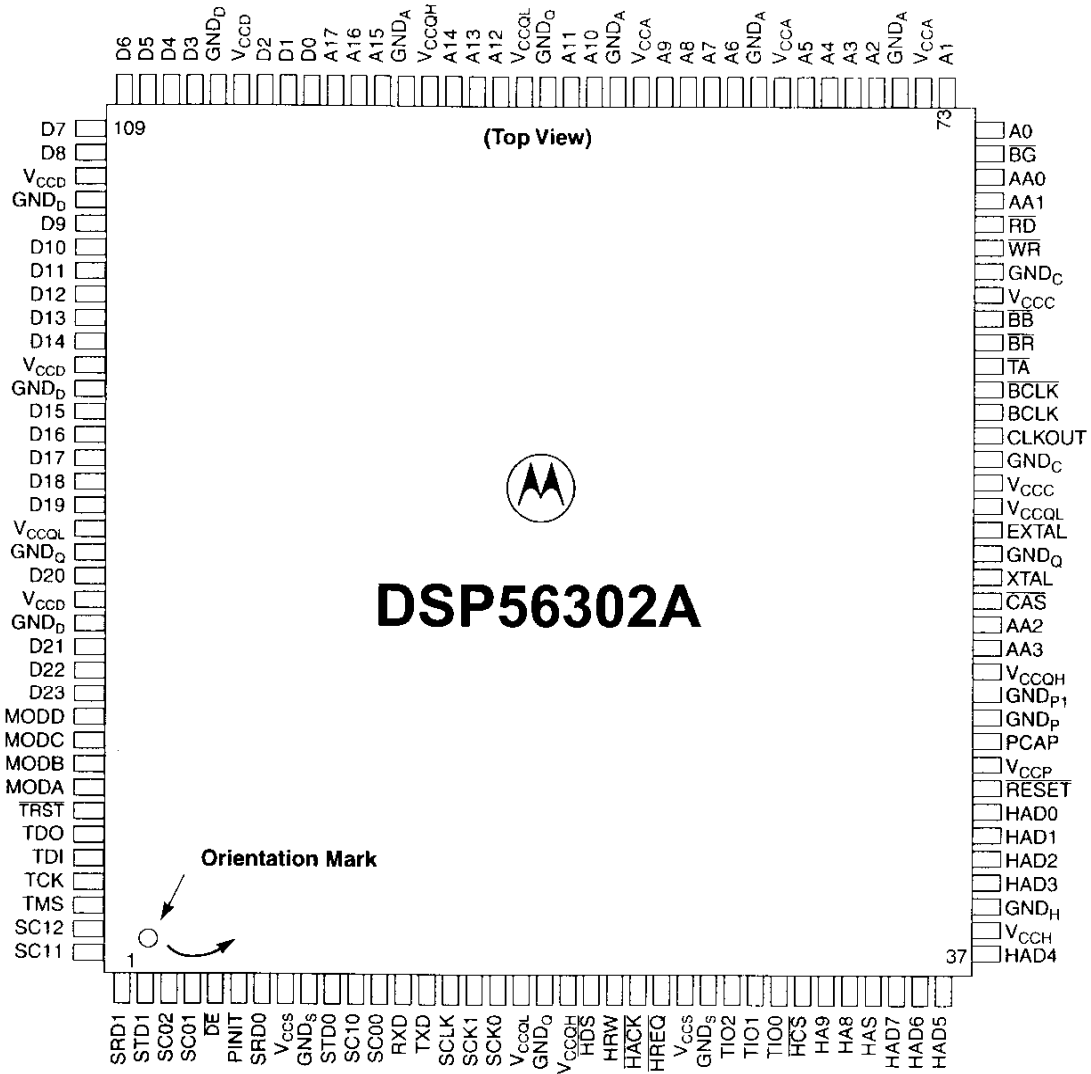

Note: Because of size constraints in this figure, only one name is shown for multiplexed pins. Refer to **Table 3-1** and **Table 3-2** for detailed information about pin functions and signal names.

AA0301

**Figure 3-1** DSP56302A Thin Quad Flat Pack (TQFP), Top View

**Preliminary Information**



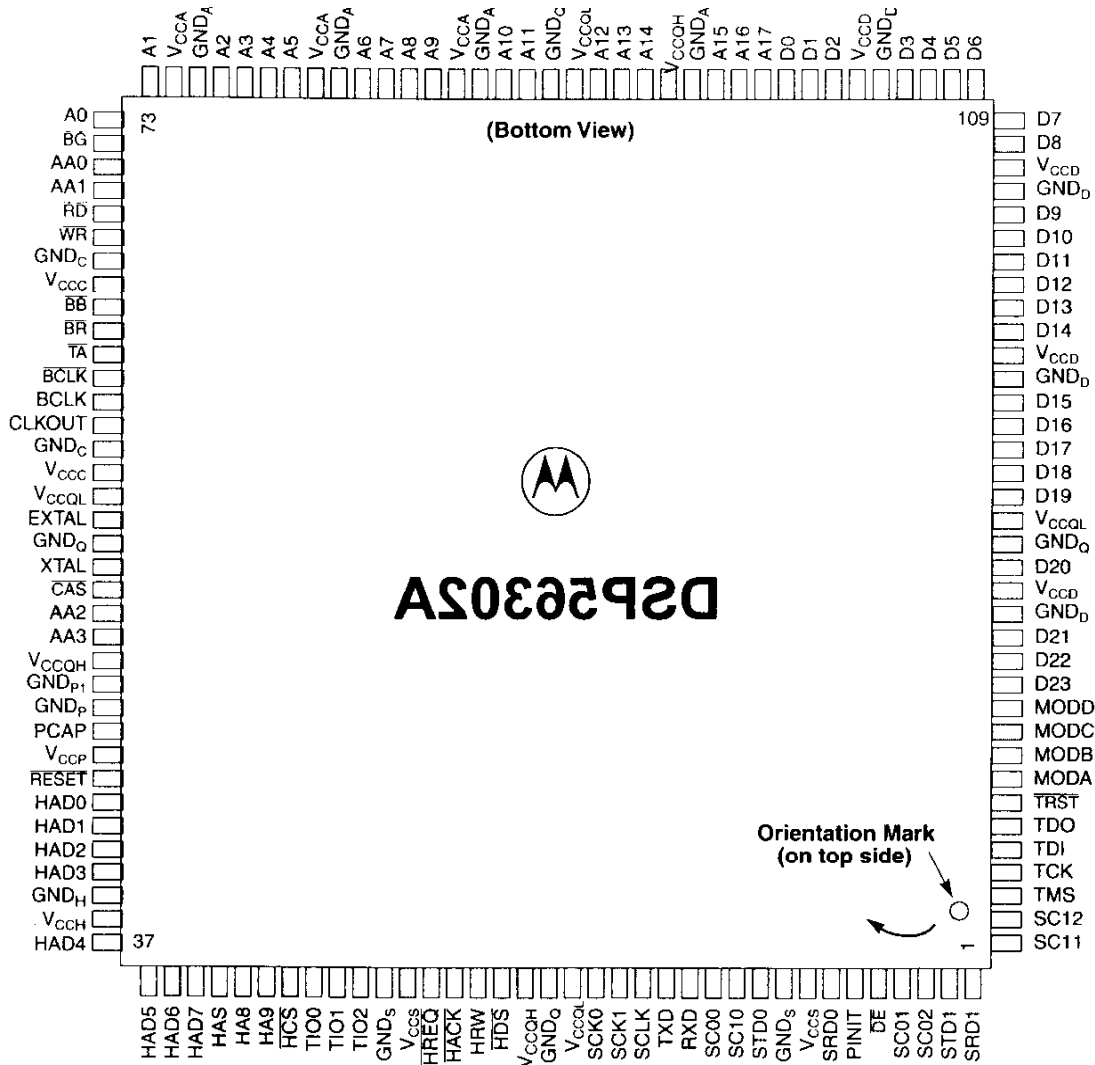

Note: Because of size constraints in this figure, only one name is shown for multiplexed pins. Refer to **Table 3-1** and **Table 3-2** for detailed information about pin functions and signal names.

AA0302

Figure 3-2 DSP56302A Thin Quad Flat Pack (TQFP), Bottom View

## Packaging

### Pin-out and Package Information

Table 3-1 DSP56302A TQFP Signal Identification by Pin Number

Pin No.	Signal Name	Pin No.	Signal Name	Pin No.	Signal Name
1	SRD1 or PD4	26	GND <sub>S</sub>	51	AA2/ $\overline{\text{RAS2}}$
2	STD1 or PD5	27	TIO2	52	$\overline{\text{CAS}}$
3	SC02 or PC2	28	TIO1	53	XTAL
4	SC01 or PC1	29	TIO0	54	GND <sub>Q</sub>
5	$\overline{\text{DE}}$	30	$\overline{\text{HCS}}/\text{HCS}$ , HA10, or PB13	55	EXTAL
6	PINIT/ $\overline{\text{NM}}\overline{\text{I}}$	31	HA2, HA9, or PB10	56	V <sub>CCQL</sub>
7	SRD0 or PC4	32	HA1, HA8, or PB9	57	V <sub>CCC</sub>
8	V <sub>CCS</sub>	33	HA0, $\overline{\text{HAS}}/\text{HAS}$ , or PB8	58	GND <sub>C</sub>
9	GND <sub>S</sub>	34	H7, HAD7, or PB7	59	CLKOUT
10	STD0 or PC5	35	H6, HAD6, or PB6	60	BCLK
11	SC10 or PD0	36	H5, HAD5, or PB5	61	$\overline{\text{BCLK}}$
12	SC00 or PC0	37	H4, HAD4, or PB4	62	$\overline{\text{TA}}$
13	RXD or PE0	38	V <sub>CCH</sub>	63	$\overline{\text{BR}}$
14	TXD or PE1	39	GND <sub>H</sub>	64	BB
15	SCLK or PE2	40	H3, HAD3, or PB3	65	V <sub>CCC</sub>
16	SCK1 or PD3	41	H2, HAD2, or PB2	66	GND <sub>C</sub>
17	SCK0 or PC3	42	H1, HAD1, or PB1	67	$\overline{\text{WR}}$
18	V <sub>CCQL</sub>	43	H0, HAD0, or PB0	68	$\overline{\text{RD}}$
19	GND <sub>Q</sub>	44	$\overline{\text{RESET}}$	69	AA1/ $\overline{\text{RAS1}}$
20	V <sub>CCQH</sub>	45	V <sub>CCP</sub>	70	AA0/ $\overline{\text{RAS0}}$
21	$\overline{\text{HDS}}/\text{HDS}$ , $\overline{\text{HWR}}/\text{HWR}$ , or PB12	46	PCAP	71	$\overline{\text{BG}}$
22	HRW, $\overline{\text{HRD}}/\text{HRD}$ , or PB11	47	GND <sub>P</sub>	72	A0
23	$\overline{\text{HACK}}/\text{HACK}$ , $\overline{\text{HRRQ}}/\text{HRRQ}$ , or PB15	48	GND <sub>P1</sub>	73	A1
24	$\overline{\text{HREQ}}/\text{HREQ}$ , $\overline{\text{HTRQ}}/\text{HTRQ}$ , or PB14	49	V <sub>CCQH</sub>	74	V <sub>CCA</sub>
25	V <sub>CCS</sub>	50	AA3/ $\overline{\text{RAS3}}$	75	GND <sub>A</sub>

### Preliminary Information

Table 3-1 DSP56302A TQFP Signal Identification by Pin Number (Continued)

Pin No.	Signal Name	Pin No.	Signal Name	Pin No.	Signal Name
76	A2	99	A17	122	D16
77	A3	100	D0	123	D17
78	A4	101	D1	124	D18
79	A5	102	D2	125	D19
80	V <sub>CCA</sub>	103	V <sub>CCD</sub>	126	V <sub>CCQL</sub>
81	GND <sub>A</sub>	104	GND <sub>D</sub>	127	GND <sub>Q</sub>
82	A6	105	D3	128	D20
83	A7	106	D4	129	V <sub>CCD</sub>
84	A8	107	D5	130	GND <sub>D</sub>
85	A9	108	D6	131	D21
86	V <sub>CCA</sub>	109	D7	132	D22
87	GND <sub>A</sub>	110	D8	133	D23
88	A10	111	V <sub>CCD</sub>	134	MODD/ $\overline{\text{IRQD}}$
89	A11	112	GND <sub>D</sub>	135	MODC/ $\overline{\text{IRQC}}$
90	GND <sub>Q</sub>	113	D9	136	MODB/ $\overline{\text{IRQB}}$
91	V <sub>CCQL</sub>	114	D10	137	MODA/ $\overline{\text{IRQA}}$
92	A12	115	D11	138	$\overline{\text{TRST}}$
93	A13	116	D12	139	TDO
94	A14	117	D13	140	TDI
95	V <sub>CCQH</sub>	118	D14	141	TCK
96	GND <sub>A</sub>	119	V <sub>CCD</sub>	142	TMS
97	A15	120	GND <sub>D</sub>	143	SC12 or PD2
98	A16	121	D15	144	SC11 or PD1

Note: Signal names are based on configured functionality. Most pins supply a single signal. Some pins provide a signal with dual functionality, such as the MODx/ $\overline{\text{IRQx}}$  pins that select an operating mode after RESET is deasserted, but act as interrupt lines during operation. Some signals have configurable polarity; these names are shown with and without overbars, such as  $\overline{\text{HAS}}$ /HAS. Some pins have two or more configurable functions; names assigned to these pins indicate the function for a specific configuration. For example, Pin 34 is data line H7 in Non-multiplexed Bus mode, data/address line HAD7 in Multiplexed Bus mode, or GPIO line PB7 when the GPIO function is enabled for this pin.

## Preliminary Information

**Packaging**

**Pin-out and Package Information**

**Table 3-2 DSP56302A TQFP Signal Identification by Name**

Signal Name	Pin No.	Signal Name	Pin No.	Signal Name	Pin No.
A0	72	$\overline{BG}$	71	D7	109
A1	73	$\overline{BR}$	63	D8	110
A10	88	$\overline{CAS}$	52	D9	113
A11	89	CLKOUT	59	$\overline{DE}$	5
A12	92	D0	100	EXTAL	55
A13	93	D1	101	GND <sub>A</sub>	75
A14	94	D10	114	GND <sub>A</sub>	81
A15	97	D11	115	GND <sub>A</sub>	87
A16	98	D12	116	GND <sub>A</sub>	96
A17	99	D13	117	GND <sub>C</sub>	58
A2	76	D14	118	GND <sub>C</sub>	66
A3	77	D15	121	GND <sub>D</sub>	104
A4	78	D16	122	GND <sub>D</sub>	112
A5	79	D17	123	GND <sub>D</sub>	120
A6	82	D18	124	GND <sub>D</sub>	130
A7	83	D19	125	GND <sub>H</sub>	39
A8	84	D2	102	GND <sub>P</sub>	47
A9	85	D20	128	GND <sub>P1</sub>	48
AA0	70	D21	131	GND <sub>Q</sub>	19
AA1	69	D22	132	GND <sub>Q</sub>	54
AA2	51	D23	133	GND <sub>Q</sub>	90
AA3	50	D3	105	GND <sub>Q</sub>	127
$\overline{BB}$	64	D4	106	GND <sub>S</sub>	9
BCLK	60	D5	107	GND <sub>S</sub>	26
$\overline{BCLK}$	61	D6	108	H0	43

**Preliminary Information**

Table 3-2 DSP56302A TQFP Signal Identification by Name (Continued)

Signal Name	Pin No.	Signal Name	Pin No.	Signal Name	Pin No.
H1	42	$\overline{\text{HRD}}/\text{HRD}$	22	PB4	37
H2	41	$\overline{\text{HREQ}}/\text{HREQ}$	24	PB5	36
H3	40	$\overline{\text{HRRQ}}/\text{HRRQ}$	23	PB6	35
H4	37	HRW	22	PB7	34
H5	36	$\overline{\text{HTRQ}}/\text{HTRQ}$	24	PB8	33
H6	35	$\overline{\text{HWR}}/\text{HWR}$	21	PB9	32
H7	34	$\overline{\text{IRQA}}$	137	PC0	12
HA0	33	$\overline{\text{IRQB}}$	136	PC1	4
HA1	32	$\overline{\text{IRQC}}$	135	PC2	3
HA10	30	$\overline{\text{IRQD}}$	134	PC3	17
HA2	31	MODA	137	PC4	7
HA8	32	MODB	136	PC5	10
HA9	31	MODC	135	PCAP	46
$\overline{\text{HACK}}/\text{HACK}$	23	MODD	134	PD0	11
HAD0	43	NMI	6	PD1	144
HAD1	42	PB0	43	PD2	143
HAD2	41	PB1	42	PD3	16
HAD3	40	PB10	31	PD4	1
HAD4	37	PB11	22	PD5	2
HAD5	36	PB12	21	PE0	13
HAD6	35	PB13	30	PE1	14
HAD7	34	PB14	24	PE2	15
HAS	33	PB15	23	PINIT	6
$\overline{\text{HCS}}/\text{HCS}$	30	PB2	41	$\overline{\text{RAS0}}$	70
$\overline{\text{HDS}}/\text{HDS}$	21	PB3	40	$\overline{\text{RAS1}}$	69

## Preliminary Information

**Packaging****Pin-out and Package Information****Table 3-2 DSP56302A TQFP Signal Identification by Name (Continued)**

Signal Name	Pin No.	Signal Name	Pin No.	Signal Name	Pin No.
RAS $\bar{2}$	51	STD1	2	V <sub>CCD</sub>	111
RAS $\bar{3}$	50	T $\bar{A}$	62	V <sub>CCD</sub>	119
R $\bar{D}$	68	TCK	141	V <sub>CCD</sub>	129
RE $\bar{S}E\bar{T}$	44	TDI	140	V <sub>CCH</sub>	38
RXD	13	TDO	139	V <sub>CCP</sub>	45
SC00	12	TIO0	29	V <sub>CCQH</sub>	20
SC01	4	TIO1	28	V <sub>CCQH</sub>	49
SC02	3	TIO2	27	V <sub>CCQH</sub>	95
SC10	11	TMS	142	V <sub>CCQL</sub>	18
SC11	144	T $\bar{R}S\bar{T}$	138	V <sub>CCQL</sub>	56
SC12	143	TXD	14	V <sub>CCQL</sub>	91
SCK0	17	V <sub>CCA</sub>	74	V <sub>CCQL</sub>	126
SCK1	16	V <sub>CCA</sub>	80	V <sub>CCS</sub>	8
SCLK	15	V <sub>CCA</sub>	86	V <sub>CCS</sub>	25
SRD0	7	V <sub>CCC</sub>	57	W $\bar{R}$	67
SRD1	1	V <sub>CCC</sub>	65	XTAL	53
STD0	10	V <sub>CCD</sub>	103		

**Preliminary Information**

### TQFP Package Mechanical Drawing

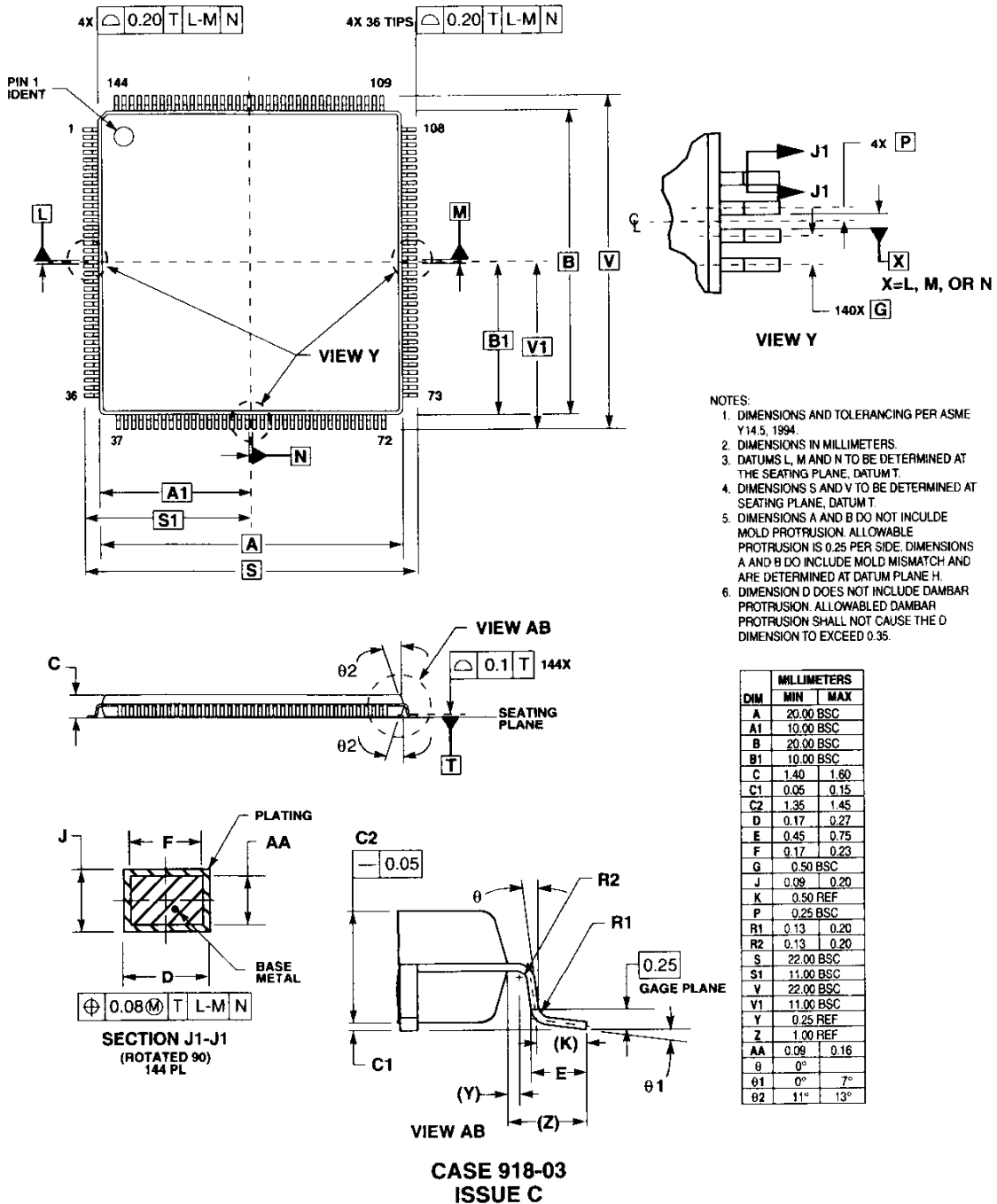

Figure 3-3 DSP56302A Mechanical Information, 144-pin TQFP Package

Preliminary Information

**Packaging**

**Pin-out and Package Information**

**PBGA Package Description**

Top and bottom views of the PBGA package are shown in **Figure 3-4** and **Figure 3-5** with their pin-outs.

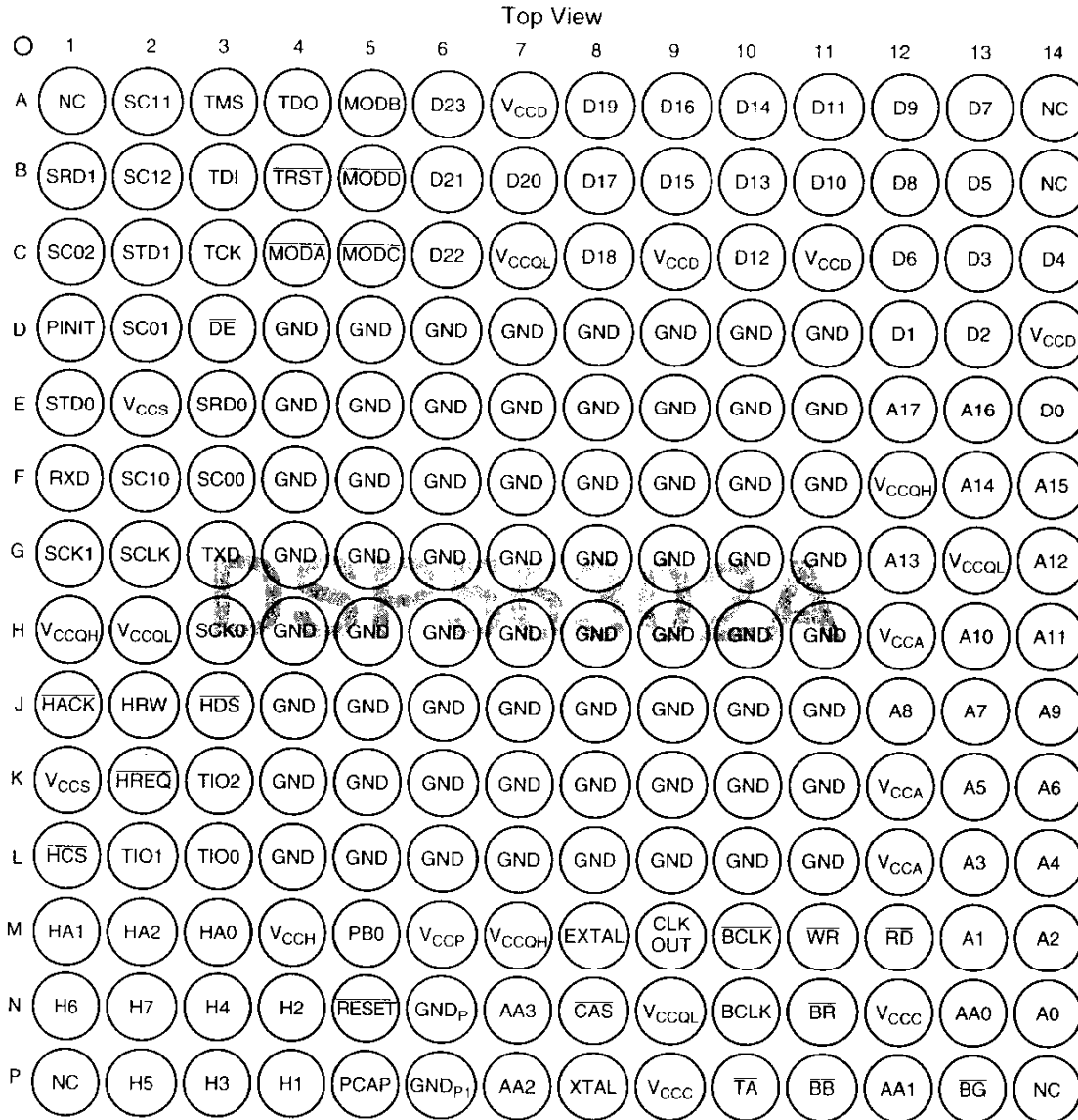

**Figure 3-4** DSP56302A Plastic Ball Grid Array (PBGA), Top View

**Preliminary Information**



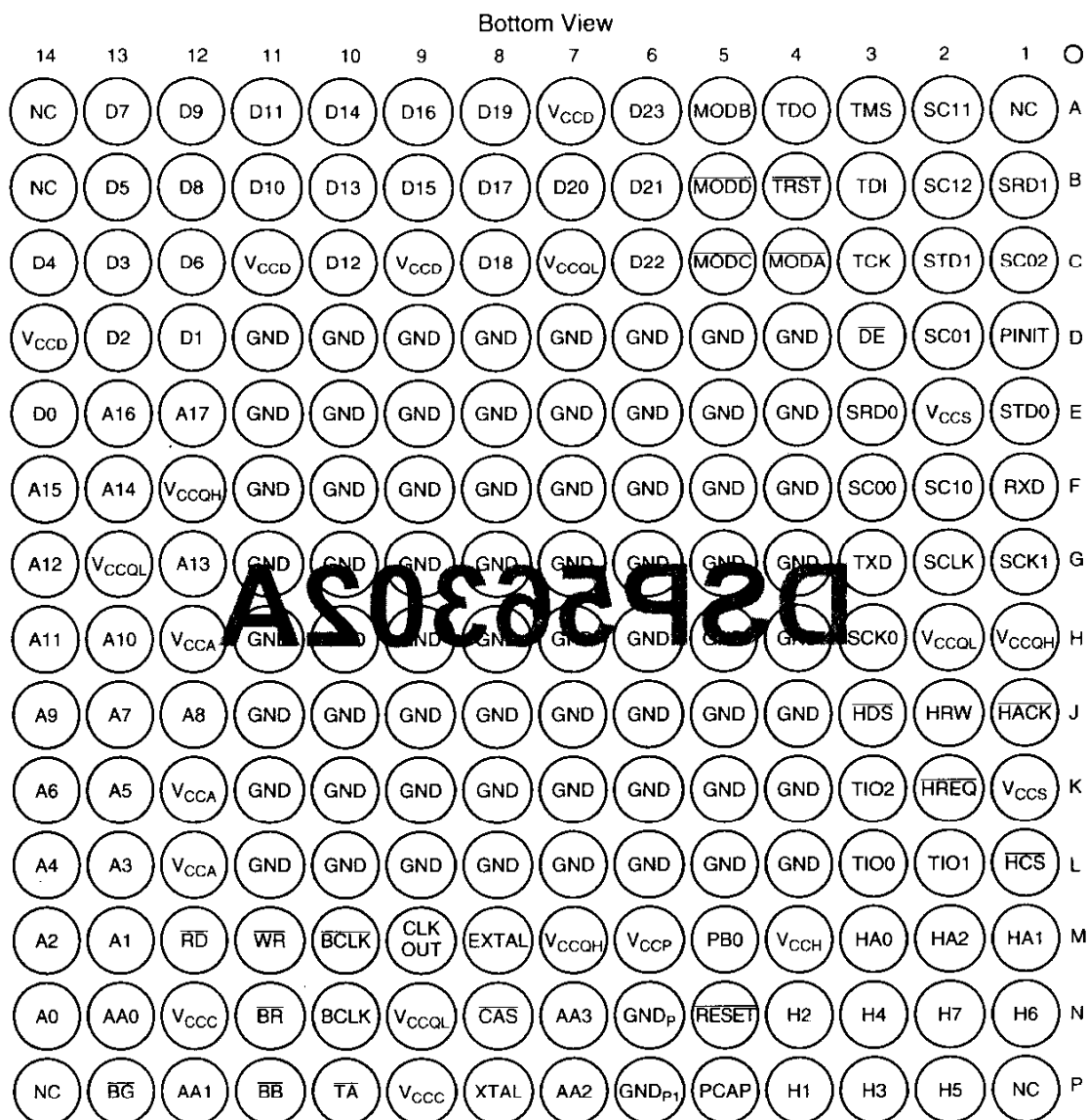

Figure 3-5 DSP56302A Plastic Ball Grid Array (PBGA), Bottom View

Preliminary Information

## Packaging

### Pin-out and Package Information

Table 3-3 DSP56302A PBGA Signal Identification by Pin Number

Pin No.	Signal Name	Pin No.	Signal Name	Pin No.	Signal Name
A1	Not Connected (NC), reserved	B12	D8	D9	GND
A2	SC11 or PD1	B13	D5	D10	GND
A3	TMS	B14	NC	D11	GND
A4	TDO	C1	SC02 or PC2	D12	D1
A5	MODB/ $\overline{\text{IRQB}}$	C2	STD1 or PD5	D13	D2
A6	D23	C3	TCK	D14	V <sub>CCD</sub>
A7	V <sub>CCD</sub>	C4	MODA/ $\overline{\text{IRQA}}$	E1	STD0 or PC5
A8	D19	C5	MODC/ $\overline{\text{IRQC}}$	E2	V <sub>CCS</sub>
A9	D16	C6	D22	E3	SRD0 or PC4
A10	D14	C7	V <sub>CCQL</sub>	E4	GND
A11	D11	C8	D18	E5	GND
A12	D9	C9	V <sub>CCD</sub>	E6	GND
A13	D7	C10	D12	E7	GND
A14	NC	C11	V <sub>CCD</sub>	E8	GND
B1	SRD1 or PD4	C12	D6	E9	GND
B2	SC12 or PD2	C13	D3	E10	GND
B3	TDI	C14	D4	E11	GND
B4	$\overline{\text{TRST}}$	D1	PINIT/ $\overline{\text{NMI}}$	E12	A17
B5	MODD/ $\overline{\text{IRQD}}$	D2	SC01 or PC1	E13	A16
B6	D21	D3	$\overline{\text{DE}}$	E14	D0
B7	D20	D4	GND	F1	RXD or PE0
B8	D17	D5	GND	F2	SC10 or PD0
B9	D15	D6	GND	F3	SC00 or PC0
B10	D13	D7	GND	F4	GND
B11	D10	D8	GND	F5	GND

### Preliminary Information

Table 3-3 DSP56302A PBGA Signal Identification by Pin Number (Continued)

Pin No.	Signal Name	Pin No.	Signal Name	Pin No.	Signal Name
F6	GND	H3	SCK0 or PC3	J14	A9
F7	GND	H4	GND	K1	V <sub>CCS</sub>
F8	GND	H5	GND	K2	HREQ/HREQ, HTRQ/HTRQ, or PB14
F9	GND	H6	GND	K3	TIO2
F10	GND	H7	GND	K4	GND
F11	GND	H8	GND	K5	GND
F12	V <sub>CCQH</sub>	H9	GND	K6	GND
F13	A14	H10	GND	K7	GND
F14	A15	H11	GND	K8	GND
G1	SCK1 or PD3	H12	V <sub>CCA</sub>	K9	GND
G2	SCLK or PE2	H13	A10	K10	GND
G3	TXD or PE1	H14	A11	K11	GND
G4	GND	J1	HACK/HACK, HRRQ/HRRQ, or PB15	K12	V <sub>CCA</sub>
G5	GND	J2	HRW, HRD/HRD, or PB11	K13	A5
G6	GND	J3	HDS/HDS, HWR/HWR, or PB12	K14	A6
G7	GND	J4	GND	L1	HCS/HCS, HA10, or PB13
G8	GND	J5	GND	L2	TIO1
G9	GND	J6	GND	L3	TIO0
G10	GND	J7	GND	L4	GND
G11	GND	J8	GND	L5	GND
G12	A13	J9	GND	L6	GND
G13	V <sub>CCQL</sub>	J10	GND	L7	GND
G14	A12	J11	GND	L8	GND
H1	V <sub>CCQH</sub>	J12	A8	L9	GND
H2	V <sub>CCQL</sub>	J13	A7	L10	GND

## Preliminary Information

## Packaging

### Pin-out and Package Information

Table 3-3 DSP56302A PBGA Signal Identification by Pin Number (Continued)

Pin No.	Signal Name	Pin No.	Signal Name	Pin No.	Signal Name
L11	GND	M13	A1	P1	NC
L12	V <sub>CCA</sub>	M14	A2	P2	H5, HAD5, or PB5
L13	A3	N1	H6, HAD6, or PB6	P3	H3, HAD3, or PB3
L14	A4	N2	H7, HAD7, or PB7	P4	H1, HAD1, or PB1
M1	HA1, HA8, or PB9	N3	H4, HAD4, or PB4	P5	PCAP
M2	HA2, HA9, or PB10	N4	H2, HAD2, or PB2	P6	GND <sub>P1</sub>
M3	HA0, $\overline{\text{HAS}}$ /HAS, or PB8	N5	$\overline{\text{RESET}}$	P7	AA2/ $\overline{\text{RAS2}}$
M4	V <sub>CCH</sub>	N6	GND <sub>P</sub>	P8	XTAL
M5	H0, HAD0, or PB0	N7	AA3/ $\overline{\text{RAS3}}$	P9	V <sub>CCC</sub>
M6	V <sub>CCP</sub>	N8	$\overline{\text{CAS}}$	P10	$\overline{\text{TA}}$
M7	V <sub>CCQH</sub>	N9	V <sub>CCQL</sub>	P11	BB
M8	EXTAL	N10	BCLK	P12	AA1/ $\overline{\text{RAS1}}$
M9	CLKOUT	N11	$\overline{\text{BR}}$	P13	$\overline{\text{BG}}$
M10	$\overline{\text{BCLK}}$	N12	V <sub>CCC</sub>	P14	NC
M11	$\overline{\text{WR}}$	N13	AA0/ $\overline{\text{RAS0}}$		
M12	$\overline{\text{RD}}$	N14	A0		

**Note:** Signal names are based on configured functionality. Most connections supply a single signal. Some connections provide a signal with dual functionality, such as the MODx/ $\overline{\text{IRQx}}$  pins that select an operating mode after  $\overline{\text{RESET}}$  is deasserted, but act as interrupt lines during operation. Some signals have configurable polarity; these names are shown with and without overbars, such as  $\overline{\text{HAS}}$ /HAS. Some connections have two or more configurable functions; names assigned to these connections indicate the function for a specific configuration. For example, connection N2 is data line H7 in Non-multiplexed Bus mode, data/address line HAD7 in Multiplexed Bus mode, or GPIO line PB7 when the GPIO function is enabled for this pin. Unlike the TQFP package, most of the GND pins are connected internally in the center of the connection array and act as heat sink for the chip. Therefore, except for GND<sub>P</sub> and GND<sub>P1</sub> that support the PLL, other GND signals do not support individual subsystems in the chip.

### Preliminary Information

Table 3-4 DSP56302A PBGA Signal Identification by Name

Signal Name	Pin No.	Signal Name	Pin No.	Signal Name	Pin No.
A0	N14	$\overline{BC}$	P13	D7	A13
A1	M13	$\overline{BR}$	N11	D8	B12
A10	H13	$\overline{CAS}$	N8	D9	A12
A11	H14	CLKOUT	M9	$\overline{DE}$	D3
A12	G14	D0	E14	EXTAL	M8
A13	G12	D1	D12	GND	D4
A14	F13	D10	B11	GND	D5
A15	F14	D11	A11	GND	D6
A16	E13	D12	C10	GND	D7
A17	E12	D13	B10	GND	D8
A2	M14	D14	A10	GND	D9
A3	L13	D15	B9	GND	D10
A4	L14	D16	A9	GND	D11
A5	K13	D17	B8	GND	E4
A6	K14	D18	C8	GND	E5
A7	J13	D19	A8	GND	E6
A8	J12	D2	D13	GND	E7
A9	J14	D20	B7	GND	E8
AA0	N13	D21	B6	GND	E9
AA1	P12	D22	C6	GND	E10
AA2	P7	D23	A6	GND	E11
AA3	N7	D3	C13	GND	F4
$\overline{BB}$	P11	D4	C14	GND	F5
$\overline{BCLK}$	M10	D5	B13	GND	F6
BCLK	N10	D6	C12	GND	F7

## Preliminary Information

**Packaging**

**Pin-out and Package Information**

**Table 3-4 DSP56302A PBGA Signal Identification by Name (Continued)**

Signal Name	Pin No.	Signal Name	Pin No.	Signal Name	Pin No.
GND	F8	GND	J9	H4	N3
GND	F9	GND	J10	H5	P2
GND	F10	GND	J11	H6	N1
GND	F11	GND	K4	H7	N2
GND	G4	GND	K5	HA0	M3
GND	G5	GND	K6	HA1	M1
GND	G6	GND	K7	HA10	L1
GND	G7	GND	K8	HA2	M2
GND	G8	GND	K9	HA8	M1
GND	G9	GND	K10	HA9	M2
GND	G10	GND	K11	HACK/HACK	J1
GND	G11	GND	L4	HAD0	M5
GND	H4	GND	L5	HAD1	P4
GND	H5	GND	L6	HAD2	N4
GND	H6	GND	L7	HAD3	P3
GND	H7	GND	L8	HAD4	N3
GND	H8	GND	L9	HAD5	P2
GND	H9	GND	L10	HAD6	N1
GND	H10	GND	L11	HAD7	N2
GND	H11	GND <sub>P</sub>	N6	$\overline{\text{HAS}}$ /HAS	M3
GND	J4	GND <sub>P1</sub>	P6	$\overline{\text{HCS}}$ /HCS	L1
GND	J5	H0	M5	HDS/HDS	J3
GND	J6	H1	P4	HRD/HRD	J2
GND	J7	H2	N4	HREQ/HREQ	K2
GND	J8	H3	P3	$\overline{\text{HRRQ}}$ /HRRQ	J1

**Preliminary Information**

Table 3-4 DSP56302A PBGA Signal Identification by Name (Continued)

Signal Name	Pin No.	Signal Name	Pin No.	Signal Name	Pin No.
HRW	J2	PB2	N4	RAS0	N13
HTRQ/HTRQ	K2	PB3	P3	RAS1	P12
HWR/HWR	J3	PB4	N3	RAS2	P7
IRQA	C4	PB5	P2	RAS3	N7
IRQB	A5	PB6	N1	RD	M12
IRQC	C5	PB7	N2	RESET	N5
IRQD	B5	PB8	M3	RXD	F1
MODA	C4	PB9	M1	SC00	F3
MODB	A5	PC0	F3	SC01	D2
MODC	C5	PC1	D2	SC02	C1
MODD	B5	PC2	C1	SC10	F2
NC	A1	PC3	H3	SC11	A2
NC	A14	PC4	E3	SC12	B2
NC	B14	PC5	E1	SCK0	H3
NC	P1	PCAP	P5	SCK1	G1
NC	P14	PD0	F2	SCLK	G2
NMI	D1	PD1	A2	SRD0	E3
PB0	M5	PD2	B2	SRD1	B1
PB1	P4	PD3	G1	STD0	E1
PB10	M2	PD4	B1	STD1	C2
PB11	J2	PD5	C2	TA	P10
PB12	J3	PE0	F1	TCK	C3
PB13	L1	PE1	G3	TDI	B3
PB14	K2	PE2	G2	TDO	A4
PB15	J1	PINIT	D1	TIO0	L3

## Preliminary Information

**Packaging****Pin-out and Package Information****Table 3-4 DSP56302A PBGA Signal Identification by Name (Continued)**

Signal Name	Pin No.	Signal Name	Pin No.	Signal Name	Pin No.
TIO1	L2	V <sub>CC</sub>	P9	V <sub>CCQH</sub>	M77
TIO2	K3	V <sub>CCD</sub>	A7	V <sub>CCQL</sub>	C7
TMS	A3	V <sub>CCD</sub>	C9	V <sub>CCQL</sub>	G13
$\overline{\text{TRST}}$	B4	V <sub>CCD</sub>	C11	V <sub>CCQL</sub>	H2
TXD	G3	V <sub>CCD</sub>	D14	V <sub>CCQL</sub>	N9
V <sub>CCA</sub>	H12	V <sub>CCH</sub>	M4	V <sub>CCS</sub>	E2
V <sub>CCA</sub>	K12	V <sub>CCP</sub>	M6	V <sub>CCS</sub>	K1
V <sub>CCA</sub>	L12	V <sub>CCQH</sub>	F12	$\overline{\text{WR}}$	M11
V <sub>CC</sub>	N12	V <sub>CCQH</sub>	H1	XTAL	P8

**Preliminary Information**



### PBGA Package Mechanical Drawing

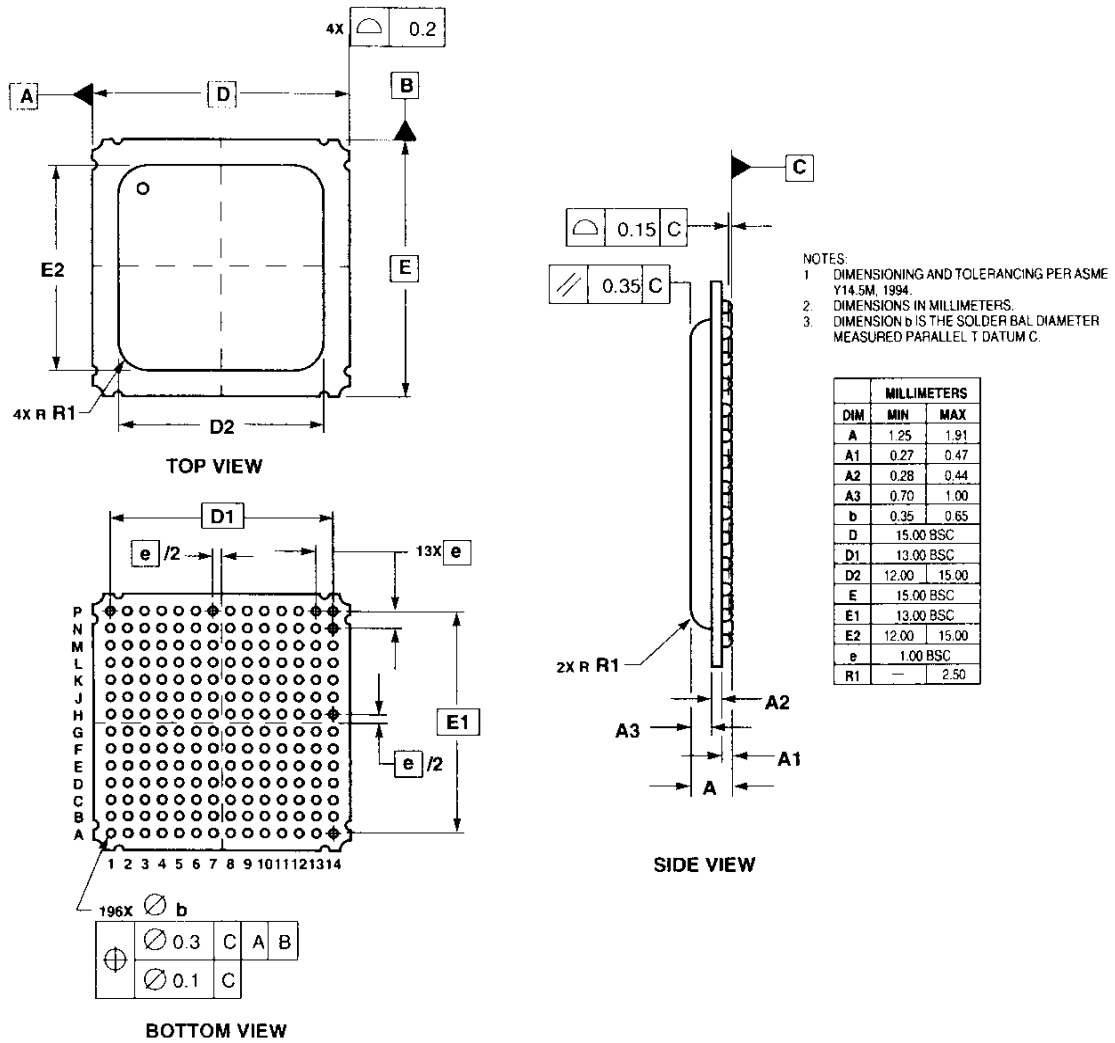

CASE 1128-01  
ISSUE B

DATE 11/22/96

Figure 3-6 DSP56302A Mechanical Information, 196-pin PBGA Package

Preliminary Information

## ORDERING DRAWINGS

Complete mechanical information regarding DSP56302A packaging is available by facsimile through Motorola's Mfax system. Call the following number to obtain information by facsimile:

(602) 244-6609

The Mfax automated system requests the following information:

- The receiving facsimile telephone number including area code or country code
- The caller's Personal Identification Number (PIN)

**Note:** For first time callers, the system provides instructions for setting up a PIN, which requires entry of a name and telephone number.

- The type of information requested:
  - Instructions for using the system
  - A literature order form
  - Specific part technical information or data sheets
  - Other information described by the system messages

A total of three documents may be ordered per call.

The DSP56302A 144-pin TQFP package mechanical drawing is referenced as 918-03. The reference number for the 196-pin PBGA package is 1128-01.



# SECTION 4

## DESIGN CONSIDERATIONS

---

---

### THERMAL DESIGN CONSIDERATIONS

An estimation of the chip junction temperature,  $T_J$ , in °C can be obtained from the equation:

**Equation 1:**  $T_J = T_A + (P_D \times R_{\theta JA})$

Where:

- $T_A$  = ambient temperature °C
- $R_{\theta JA}$  = package junction-to-ambient thermal resistance °C/W
- $P_D$  = power dissipation in package

Historically, thermal resistance has been expressed as the sum of a junction-to-case thermal resistance and a case-to-ambient thermal resistance:

**Equation 2:**  $R_{\theta JA} = R_{\theta JC} + R_{\theta CA}$

Where:

- $R_{\theta JA}$  = package junction-to-ambient thermal resistance °C/W
- $R_{\theta JC}$  = package junction-to-case thermal resistance °C/W
- $R_{\theta CA}$  = package case-to-ambient thermal resistance °C/W

$R_{\theta JC}$  is device-related and cannot be influenced by the user. The user controls the thermal environment to change the case-to-ambient thermal resistance,  $R_{\theta CA}$ . For example, the user can change the air flow around the device, add a heat sink, change the mounting arrangement on the Printed Circuit Board (PCB), or otherwise change the thermal dissipation capability of the area surrounding the device on a PCB. This model is most useful for ceramic packages with heat sinks; some 90% of the heat flow is dissipated through the case to the heat sink and out to the ambient environment. For ceramic packages, in situations where the heat flow is split between a path to the case and an alternate path through the PCB, analysis of the device thermal performance may need the additional modeling capability of a system level thermal simulation tool.

#### Preliminary Information

## Design Considerations

### Thermal Design Considerations

---

The thermal performance of plastic packages is more dependent on the temperature of the PCB to which the package is mounted. Again, if the estimations obtained from  $R_{\theta JA}$  do not satisfactorily answer whether the thermal performance is adequate, a system level model may be appropriate.

A complicating factor is the existence of three common ways for determining the junction-to-case thermal resistance in plastic packages:

- To minimize temperature variation across the surface, the thermal resistance is measured from the junction to the outside surface of the package (case) closest to the chip mounting area when that surface has a proper heat sink.
- To define a value approximately equal to a junction-to-board thermal resistance, the thermal resistance is measured from the junction to where the leads are attached to the case.
- If the temperature of the package case ( $T_T$ ) is determined by a thermocouple, the thermal resistance is computed using the value obtained by the equation  $(T_J - T_T)/P_D$ .

As noted above, the junction-to-case thermal resistances quoted in this data sheet are determined using the first definition. From a practical standpoint, that value is also suitable for determining the junction temperature from a case thermocouple reading in forced convection environments. In natural convection, using the junction-to-case thermal resistance to estimate junction temperature from a thermocouple reading on the case of the package will estimate a junction temperature slightly hotter than actual temperature. Hence, the new thermal metric, Thermal Characterization Parameter or  $\Psi_{JT}$ , has been defined to be  $(T_J - T_T)/P_D$ . This value gives a better estimate of the junction temperature in natural convection when using the surface temperature of the package. Remember that surface temperature readings of packages are subject to significant errors caused by inadequate attachment of the sensor to the surface and to errors caused by heat loss to the sensor. The recommended technique is to attach a 40-gauge thermocouple wire and bead to the top center of the package with thermally conductive epoxy.

### Preliminary Information

## ELECTRICAL DESIGN CONSIDERATIONS

### CAUTION

This device contains protective circuitry to guard against damage due to high static voltage or electrical fields. However, normal precautions are advised to avoid application of any voltages higher than maximum rated voltages to this high-impedance circuit. Reliability of operation is enhanced if unused inputs are tied to an appropriate logic voltage level (e.g., either GND or  $V_{CC}$ ).

Use the following list of recommendations to assure correct DSP operation:

- Provide a low-impedance path from the board power supply to each  $V_{CC}$  pin on the DSP, and from the board ground to each GND pin.
- Use at least six 0.01–0.1  $\mu\text{F}$  bypass capacitors positioned as close as possible to the four sides of the package to connect the  $V_{CC}$  power source to GND.
- Ensure that capacitor leads and associated printed circuit traces that connect to the chip  $V_{CC}$  and GND pins are less than 0.5 in per capacitor lead.
- Use at least a four-layer PCB with two inner layers for  $V_{CC}$  and GND.
- Because the DSP output signals have fast rise and fall times, PCB trace lengths should be minimal. This recommendation particularly applies to the address and data buses as well as the  $\overline{\text{IRQA}}$ ,  $\overline{\text{IRQB}}$ ,  $\overline{\text{IRQC}}$ ,  $\overline{\text{IRQD}}$ ,  $\overline{\text{TA}}$ , and  $\overline{\text{BG}}$  pins. Maximum PCB trace lengths on the order of 6 inches are recommended.
- Consider all device loads and parasitic capacitance due to PCB traces when calculating capacitance. This is especially critical in systems with higher capacitive loads that could create higher transient currents in the  $V_{CC}$  and GND circuits.
- All inputs must be terminated (i.e., not allowed to float) using CMOS levels, except for the three pins with internal pull-up resistors ( $\overline{\text{TRST}}$ ,  $\overline{\text{TMS}}$ ,  $\overline{\text{DE}}$ ).
- Take special care to minimize noise levels on  $V_{CCP}$ ,  $\text{GND}_P$ , and  $\text{GND}_{P1}$  pins.
- The following pins must be asserted after power-up:  $\overline{\text{RESET}}$  and  $\overline{\text{TRST}}$ .
- If multiple DSP56302A devices are on the same board, check for cross-talk or excessive spikes on the supplies due to synchronous operation of the devices.

### Preliminary Information

### Power Consumption Considerations

---

- RESET must be asserted when the chip is powered up. A stable EXTAL signal should be supplied before deassertion of RESET.

## POWER CONSUMPTION CONSIDERATIONS

Power dissipation is a key issue in portable DSP applications. Some of the factors which affect current consumption are described in this section. Most of the current consumed by CMOS devices is alternating current (ac), which is charging and discharging the capacitances of the pins and internal nodes.

Current consumption is described by the formula:

**Equation 3:**  $I = C \times V \times f$

where: C = node/pin capacitance  
V = voltage swing  
f = frequency of node/pin toggle

### Example 4-1 Current Consumption

---

For a Port A address pin loaded with 50 pF capacitance, operating at 3.3 V, and with a 66 MHz clock, toggling at its maximum possible rate (33 MHz), the current consumption is:

**Equation 4:**  $I = 50 \times 10^{-12} \times 3.3 \times 33 \times 10^6 = 5.48 \text{ mA}$

---

The Maximum Internal Current ( $I_{CCI\max}$ ) value reflects the typical possible switching of the internal buses on best-case operation conditions, which is not necessarily a real application case. The Typical Internal Current ( $I_{CCI\text{typ}}$ ) value reflects the average switching of the internal buses on typical operating conditions.

For applications that require very low current consumption:

- Set the EBD bit when not accessing external memory.
- Minimize external memory accesses, and use internal memory accesses.
- Minimize the number of pins that are switching.
- Minimize the capacitive load on the pins.
- Connect the unused inputs to pull-up or pull-down resistors.
- Disable unused peripherals.
- Disable unused pin activity (e.g., CLKOUT, XTAL).

### Preliminary Information

One way to evaluate power consumption is to use a current per MIPS measurement methodology to minimize specific board effects (i.e., to compensate for measured board current not caused by the DSP). A benchmark power consumption test algorithm is listed in **Appendix A**. Use the test algorithm, specific test current measurements, and the following equation to derive the current per MIPS value:

**Equation 5:**  $I/MIPS = I/MHz = (I_{typF2} - I_{typF1}) / (F2 - F1)$

where:

- $I_{typF2}$  = current at F2
- $I_{typF1}$  = current at F1
- F2 = high frequency (any specified operating frequency)
- F1 = low frequency (any specified operating frequency less than F2)

**Note:** F1 should be significantly less than F2. For example, F2 could be 66 MHz and F1 could be 33 MHz. The degree of difference between F1 and F2 determines the amount of precision with which the current rating can be determined for an application.

## PLL PERFORMANCE ISSUES

The following explanations should be considered as general observations on expected PLL behavior. There is no testing that verifies these exact numbers. These observations were measured on a limited number of parts and were not verified over the entire temperature and voltage ranges.

### Phase Skew Performance

The phase skew of the PLL is defined as the time difference between the falling edges of EXTAL and CLKOUT for a given capacitive load on CLKOUT, over the entire process, temperature and voltage ranges. As defined in **Figure 2-2** on page 2-7, for input frequencies greater than 15 MHz and the MF  $\leq 4$ , this skew is greater than or equal to 0.0 ns and less than 1.8 ns; otherwise, this skew is not guaranteed. However, for MF  $< 10$  and input frequencies greater than 10 MHz, this skew is between -1.4 ns and +3.2 ns.

## Phase Jitter Performance

The phase jitter of the PLL is defined as the variations in the skew between the falling edges of EXTAL and CLKOUT for a given device in specific temperature, voltage, input frequency, MF, and capacitive load on CLKOUT. These variations are a result of the PLL locking mechanism. For input frequencies greater than 15 MHz and  $MF \leq 4$ , this jitter is less than  $\pm 0.6$  ns; otherwise, this jitter is not guaranteed. However, for  $MF < 10$  and input frequencies greater than 10 MHz, this jitter is less than  $\pm 2$  ns.

## Frequency Jitter Performance

The frequency jitter of the PLL is defined as the variation of the frequency of CLKOUT. For small MF ( $MF < 10$ ) this jitter is smaller than 0.5%. For mid-range MF ( $10 < MF < 500$ ) this jitter is between 0.5% and approximately 2%. For large MF ( $MF > 500$ ), the frequency jitter is 2–3%.

## Input (EXTAL) Jitter Requirements

The allowed jitter on the frequency of EXTAL is 0.5%. If the rate of change of the frequency of EXTAL is slow (i.e., it does not jump between the minimum and maximum values in one cycle) or the frequency of the jitter is fast (i.e., it does not stay at an extreme value for a long time), then the allowed jitter can be 2%. The phase and frequency jitter performance results are only valid if the input jitter is less than the prescribed values.





# SECTION 5

## ORDERING INFORMATION

Consult a Motorola Semiconductor sales office or authorized distributor to determine product availability and to place an order.

**Table 5-1** Ordering Information

Part	Supply Voltage	Package Type	Pin Count	Frequency (MHz)	Order Number
DSP56302A	3 V	Thin Quad Flat Pack (TQFP)	144	66	XC56302APV66
				80	XC56302APV80
				100	XC56302APV100
		Plastic Ball Grid Array (PBGA)	196	66	XC56302AGC66
				80	XC56302AGC80
				100	XC56302AGC100



Preliminary Information

# APPENDIX A

## POWER CONSUMPTION BENCHMARK

---

The following benchmark program permits evaluation of DSP power usage in a test situation. It enables the PLL, disables the external clock, and uses repeated Multiply-Accumulate (MAC) instructions with a set of synthetic DSP application data to emulate intensive sustained DSP operation.

```

;*****
;*****
;*
;* CHECKS    Typical Power Consumption          *
;*
;*****
page 200,55,0,0,0
nolist

I_VEC EQU $000000; Interrupt vectors for program debug only
START EQU $8000; MAIN (external) program starting address
INT_PROG EQU $100 ; INTERNAL program memory starting address
INT_XDAT EQU $0; INTERNAL X-data memory starting address
INT_YDAT EQU $0; INTERNAL Y-data memory starting address

INCLUDE "ioequ.asm"
INCLUDE "intequ.asm"

list

org P:START
;
; movep #$0123FF,x:M_BCR; BCR: Area 3 : 1 w.s (SRAM)
; Default: 1 w.s (SRAM)
;
; movep #$0d0000,x:M_PCTL ; XTAL disable
;           ; PLL enable
;           ; CLKOUT disable
;
; Load the program
;
; move #INT_PROG,r0
; move #PROG_START,r1
; do #(PROG_END-PROG_START),PLOAD_LOOP
; move p:(r1)+,x0

```

### Preliminary Information

## Power Consumption Benchmark

---

```
    move  x0,p:(r0)+
    nop
PLOAD_LOOP
;
; Load the X-data
;
    move  #INT_XDAT,r0
    move  #XDAT_START,r1
    do    #(XDAT_END-XDAT_START),XLOAD_LOOP
    move  p:(r1)+,x0
    move  x0,x:(r0)+
XLOAD_LOOP
;
; Load the Y-data
;
    move  #INT_YDAT,r0
    move  #YDAT_START,r1
    do    #(YDAT_END-YDAT_START),YLOAD_LOOP
    move  p:(r1)+,x0
    move  x0,y:(r0)+
YLOAD_LOOP
;

    jmp   INT_PROG

PROG_START
    move  #$0,r0
    move  #$0,r4
    move  #$3f,m0
    move  #$3f,m4
;
    clr   a
    clr   b
    move  #$0,x0
    move  #$0,x1
    move  #$0,y0
    move  #$0,y1
    bset  #4,omr      ; ebd
;
sbrdor  #60,_end
    mac   x0,y0,ax:(r0)+,x1 y:(r4)+,y1
    mac   x1,y1,ax:(r0)+,x0 y:(r4)+,y0
    add   a,b
    mac   x0,y0,ax:(r0)+,x1
    mac   x1,y1,a          y:(r4)+,y0
    move  b1,x:$ff
_end
```

### Preliminary Information

```
bra    sbr
nop
nop
nop
nop
PROG_END
nop
nop
```

## XDAT\_START

```
; org  x:0
dc    $262EB9
dc    $86F2FE
dc    $E56A5F
dc    $616CAC
dc    $8FFD75
dc    $9210A
dc    $A06D7B
dc    $CEA798
dc    $8DFBF1
dc    $A063D6
dc    $6C6657
dc    $C2A544
dc    $A3662D
dc    $A4E762
dc    $84F0F3
dc    $E6F1B0
dc    $B3829
dc    $8BF7AE
dc    $63A94F
dc    $EF78DC
dc    $242DE5
dc    $A3E0BA
dc    $EBAB6B
dc    $8726C8
dc    $CA361
dc    $2F6E86
dc    $A57347
dc    $4BE774
dc    $8F349D
dc    $A1ED12
dc    $4BFCE3
dc    $EA26E0
dc    $CD7D99
dc    $4BA85E
dc    $27A43F
```

## Preliminary Information

## Power Consumption Benchmark

---

```
dc    $A8B10C
dc    $D3A55
dc    $25EC6A
dc    $2A255B
dc    $A5F1F8
dc    $2426D1
dc    $AE6536
dc    $CBBC37
dc    $6235A4
dc    $37F0D
dc    $63BEC2
dc    $A5E4D3
dc    $8CE810
dc    $3FF09
dc    $60E50E
dc    $CFFB2F
dc    $40753C
dc    $8262C5
dc    $CA641A
dc    $EB3B4B
dc    $2DA928
dc    $AB6641
dc    $28A7E6
dc    $4E2127
dc    $482FD4
dc    $7257D
dc    $E53C72
dc    $1A8C3
dc    $E27540
```

XDAT\_END

YDAT\_START

```
; org    y:0
dc    $5B6DA
dc    $C3F70B
dc    $6A39E8
dc    $81E801
dc    $C666A6
dc    $46F8E7
dc    $AAEC94
dc    $24233D
dc    $802732
dc    $2E3C83
dc    $A43E00
dc    $C2B639
dc    $85A47E
dc    $ABFDDF
```

Preliminary Information

dc \$F3A2C  
dc \$2D7CF5  
dc \$E16A8A  
dc \$ECB8FB  
dc \$4BED18  
dc \$43F371  
dc \$83A556  
dc \$E1E9D7  
dc \$ACA2C4  
dc \$8135AD  
dc \$2CE0E2  
dc \$8F2C73  
dc \$432730  
dc \$A87FA9  
dc \$4A292E  
dc \$A63CCF  
dc \$6BA65C  
dc \$E06D65  
dc \$1AA3A  
dc \$A1B6EB  
dc \$48AC48  
dc \$EF7AE1  
dc \$6E3006  
dc \$62F6C7  
dc \$6064F4  
dc \$87E41D  
dc \$CB2692  
dc \$2C3863  
dc \$C6BC60  
dc \$43A519  
dc \$6139DE  
dc \$ADF7BF  
dc \$4B3E8C  
dc \$6079D5  
dc \$E0F5EA  
dc \$8230DB  
dc \$A3B778  
dc \$2BFE51  
dc \$E0A6B6  
dc \$68FFB7  
dc \$28F324  
dc \$8F2E8D  
dc \$667842  
dc \$83E053  
dc \$A1FD90  
dc \$6B2689  
dc \$85B68E

**Preliminary Information**

## Power Consumption Benchmark

---

```
dc    $622EAF
dc    $6162BC
dc    $E4A245
```

```
YDAT_END
```

```
;*****
;
;    EQUATES for DSP56302A I/O registers and ports
;
;    Last update: June 11 1995
;
;*****
```

```
page 132,55,0,0,0
opt   mex
```

```
ioequ ident 1,0
```

```
;-----
;
;    EQUATES for I/O Port Programming
;
;-----
```

```
;    Register Addresses
```

```
M_HDR EQU $FFFFC9; Host port GPIO data Register
M_HDDR EQU $FFFFC8; Host port GPIO direction Register
M_PCRC EQU $FFFFBF; Port C Control Register
M_PPRC EQU $FFFFBE      ; Port C Direction Register
M_PDRC EQU $FFFFBD      ; Port C GPIO Data Register
M_PCRD EQU $FFFFAF      ; Port D Control register
M_PPRD EQU $FFFFAE      ; Port D Direction Data Register
M_PDRD EQU $FFFFAD      ; Port D GPIO Data Register
M_PCRE EQU $FFFF9F      ; Port E Control register
M_PPRE EQU $FFFF9E      ; Port E Direction Register
M_PDRE EQU $FFFF9D      ; Port E Data Register
M_OGDB EQU $FFFFFC      ; OnCE GDB Register
```

```
;-----
;
;    EQUATES for Host Interface
;
;-----
```

```
;    Register Addresses
```

### Preliminary Information

```
M_HCR EQU $FFFFC2; Host Control Register
M_HSR EQU $FFFFC3; Host Status Register
M_HPCR EQU $FFFFC4 ; Host Polarity Control Register
M_HBAR EQU $FFFFC5; Host Base Address Register
M_HRX EQU $FFFFC6      ; Host Receive Register
M_HTX EQU $FFFFC7      ; Host Transmit Register

;      HCR bits definition
M_HRIE EQU $0          ; Host Receive interrupts Enable
M_HTIIE EQU $1         ; Host Transmit Interrupt Enable
M_HCIE EQU $2          ; Host Command Interrupt Enable
M_HF2 EQU $3           ; Host Flag 2
M_HF3 EQU $4           ; Host Flag 3

;      HSR bits definition
M_HRDF EQU $0          ; Host Receive Data Full
M_HTDE EQU $1         ; Host Receive Data Empty
M_HCP EQU $2           ; Host Command Pending
M_HF0 EQU $3           ; Host Flag 0
M_HF1 EQU $4           ; Host Flag 1

;      HPCR bits definition
M_HGEN EQU $0          ; Host Port GPIO Enable
M_HA8EN EQU $1         ; Host Address 8 Enable
M_HA9EN EQU $2         ; Host Address 9 Enable
M_HCSEN EQU $3         ; Host Chip Select Enable
M_HREN EQU $4          ; Host Request Enable
M_HAEN EQU $5 ; Host Acknowledge Enable
M_HEN EQU $6           ; Host Enable
M_HOD EQU $8           ; Host Request Open Drain mode
M_HDSP EQU $9          ; Host Data Strobe Polarity
M_HASP EQU $A          ; Host Address Strobe Polarity
M_HMUX EQU $B          ; Host Multiplexed bus select
M_HD_HS EQU $C         ; Host Double/Single Strobe select
M_HCSP EQU $D          ; Host Chip Select Polarity
M_HRP EQU $E           ; Host Request PolarityPolarity
M_HAP EQU $F           ; Host Acknowledge Polarity

;-----
;
;      EQUATES for Serial Communications Interface (SCI)
;
;-----
```

**Preliminary Information**



## Power Consumption Benchmark

---

### ; Register Addresses

M\_STXH EQU \$FFFF97 ; SCI Transmit Data Register (high)  
M\_STXM EQU \$FFFF96 ; SCI Transmit Data Register (middle)  
M\_STXL EQU \$FFFF95 ; SCI Transmit Data Register (low)  
M\_SRXH EQU \$FFFF9A ; SCI Receive Data Register (high)  
M\_SRXM EQU \$FFFF99 ; SCI Receive Data Register (middle)  
M\_SRXL EQU \$FFFF98 ; SCI Receive Data Register (low)  
M\_STXA EQU \$FFFF94 ; SCI Transmit Address Register  
M\_SCR EQU \$FFFF9C ; SCI Control Register  
M\_SSR EQU \$FFFF93 ; SCI Status Register  
M\_SCCR EQU \$FFFF9B ; SCI Clock Control Register

### ; SCI Control Register Bit Flags

M\_WDS EQU \$7 ; Word Select Mask (WDS0-WDS3)  
M\_WDS0 EQU 0 ; Word Select 0  
M\_WDS1 EQU 1 ; Word Select 1  
M\_WDS2 EQU 2 ; Word Select 2  
M\_SSFTD EQU 3 ; SCI Shift Direction  
M\_SBK EQU 4 ; Send Break  
M\_WAKE EQU 5 ; Wakeup Mode Select  
M\_RWU EQU 6 ; Receiver Wakeup Enable  
M\_WOMS EQU 7 ; Wired-OR Mode Select  
M\_SCRE EQU 8 ; SCI Receiver Enable  
M\_SCTE EQU 9 ; SCI Transmitter Enable  
M\_ILIE EQU 10 ; Idle Line Interrupt Enable  
M\_SCRIE EQU 11 ; SCI Receive Interrupt Enable  
M\_SCTIE EQU 12 ; SCI Transmit Interrupt Enable  
M\_TMIE EQU 13 ; Timer Interrupt Enable  
M\_TIR EQU 14 ; Timer Interrupt Rate  
M\_SCKP EQU 15 ; SCI Clock Polarity  
M\_REIE EQU 16 ; SCI Error Interrupt Enable (REIE)

### ; SCI Status Register Bit Flags

M\_TRNE EQU 0 ; Transmitter Empty  
M\_TDRE EQU 1 ; Transmit Data Register Empty  
M\_RDRF EQU 2 ; Receive Data Register Full  
M\_IDLE EQU 3 ; Idle Line Flag  
M\_OR EQU 4 ; Overrun Error Flag  
M\_PE EQU 5 ; Parity Error  
M\_FE EQU 6 ; Framing Error Flag  
M\_R8 EQU 7 ; Received Bit 8 (R8) Address

### ; SCI Clock Control Register

r

## Preliminary Information

```

M_CD EQU $FFF          ; Clock Divider Mask (CD0-CD11)
M_COD EQU 12           ; Clock Out Divider
M_SCP EQU 13           ; Clock Prescaler
M_RCM EQU 14           ; Receive Clock Mode Source Bit
M_TCM EQU 15           ; Transmit Clock Source Bit

;-----
;
;           EQUATES for Synchronous Serial Interface (SSI)
;
;-----

;
;           Register Addresses Of SSI0
M_TX00 EQU $FFFFBC     ; SSI0 Transmit Data Register 0
M_TX01 EQU $FFFFBB     ; SSI0 Transmit Data Register 1
M_TX02 EQU $FFFFBA     ; SSI0 Transmit Data Register 2
M_TSR0 EQU $FFFFB9     ; SSI0 Time Slot Register
M_RX0 EQU $FFFFB8      ; SSI0 Receive Data Register
M_SISR0 EQU $FFFFB7    ; SSI0 Status Register
M_CRB0 EQU $FFFFB6     ; SSI0 Control Register B
M_CRA0 EQU $FFFFB5     ; SSI0 Control Register A
M_TSMA0 EQU $FFFFB4    ; SSI0 Transmit Slot Mask Register A
M_TSMB0 EQU $FFFFB3    ; SSI0 Transmit Slot Mask Register B
M_RSMA0 EQU $FFFFB2    ; SSI0 Receive Slot Mask Register A
M_RSMB0 EQU $FFFFB1    ; SSI0 Receive Slot Mask Register B

;           Register Addresses Of SSI1
M_TX10 EQU $FFFFAC     ; SSI1 Transmit Data Register 0
M_TX11 EQU $FFFFAB     ; SSI1 Transmit Data Register 1
M_TX12 EQU $FFFFAA     ; SSI1 Transmit Data Register 2
M_TSR1 EQU $FFFFA9     ; SSI1 Time Slot Register
M_RX1 EQU $FFFFA8      ; SSI1 Receive Data Register
M_SISR1 EQU $FFFFA7    ; SSI1 Status Register
M_CRB1 EQU $FFFFA6     ; SSI1 Control Register B
M_CRA1 EQU $FFFFA5     ; SSI1 Control Register A
M_TSMA1 EQU $FFFFA4    ; SSI1 Transmit Slot Mask Register A
M_TSMB1 EQU $FFFFA3    ; SSI1 Transmit Slot Mask Register B
M_RSMA1 EQU $FFFFA2    ; SSI1 Receive Slot Mask Register A
M_RSMB1 EQU $FFFFA1    ; SSI1 Receive Slot Mask Register B

;           SSI Control Register A Bit Flags

M_PM EQU $FF           ; Prescale Modulus Select Mask (PM0-PM7)
M_PSR EQU 11           ; Prescaler Range
M_DC EQU $1F00         ; Frame Rate Divider Control Mask (DC0-DC7)

```

---

Preliminary Information

## Power Consumption Benchmark

---

```
M_ALC EQU 18          ; Alignment Control (ALC)
M_WL EQU $380000     ; Word Length Control Mask (WL0-WL7)
M_SSC1 EQU 22        ; Select SC1 as TR #0 drive enable (SSC1)

;          SSI Control Register B Bit Flags

M_OF EQU $3          ; Serial Output Flag Mask
M_OF0 EQU 0          ; Serial Output Flag 0
M_OF1 EQU 1          ; Serial Output Flag 1
M_SCD EQU $1C        ; Serial Control Direction Mask
M_SCD0 EQU 2         ; Serial Control 0 Direction
M_SCD1 EQU 3         ; Serial Control 1 Direction
M_SCD2 EQU 4         ; Serial Control 2 Direction
M_SCKD EQU 5         ; Clock Source Direction
M_SHFD EQU 6         ; Shift Direction
M_FSL EQU $180       ; Frame Sync Length Mask (FSL0-FSL1)
M_FSL0 EQU 7         ; Frame Sync Length 0
M_FSL1 EQU 8         ; Frame Sync Length 1
M_FSR EQU 9          ; Frame Sync Relative Timing
M_FSP EQU 10         ; Frame Sync Polarity
M_CKP EQU 11         ; Clock Polarity
M_SYN EQU 12         ; Sync/Async Control
M_MOD EQU 13         ; SSI Mode Select
M_SSTE EQU $1C000    ; SSI Transmit enable Mask
M_SSTE2 EQU 14       ; SSI Transmit #2 Enable
M_SSTE1 EQU 15       ; SSI Transmit #1 Enable
M_SSTE0 EQU 16       ; SSI Transmit #0 Enable
M_SSRE EQU 17        ; SSI Receive Enable
M_SSTIE EQU 18       ; SSI Transmit Interrupt Enable
M_SSRIE EQU 19       ; SSI Receive Interrupt Enable
M_STLIE EQU 20       ; SSI Transmit Last Slot Interrupt Enable
M_SRLIE EQU 21       ; SSI Receive Last Slot Interrupt Enable
M_STEIE EQU 22       ; SSI Transmit Error Interrupt Enable
M_SREIE EQU 23      ; SI Receive Error Interrupt Enable

;          SSI Status Register Bit Flags

M_IF EQU $3          ; Serial Input Flag Mask
M_IF0 EQU 0          ; Serial Input Flag 0
M_IF1 EQU 1          ; Serial Input Flag 1
M_TFS EQU 2          ; Transmit Frame Sync Flag
M_RFS EQU 3          ; Receive Frame Sync Flag
M_TUE EQU 4          ; Transmitter Underrun Error Flag
M_ROE EQU 5          ; Receiver Overrun Error Flag
M_TDE EQU 6          ; Transmit Data Register Empty
M_RDF EQU 7          ; Receive Data Register Full
```

## Preliminary Information

```

;      SSI Transmit Slot Mask Register A
M_SSTSA EQU $FFFF          ; SSI Transmit Slot Bits Mask A (TS0-TS15)

;      SSI Transmit Slot Mask Register B
M_SSTSB EQU $FFFF          ; SSI Transmit Slot Bits Mask B (TS16-TS31)

;      SSI Receive Slot Mask Register A
M_SSRSA EQU $FFFF          ; SSI Receive Slot Bits Mask A (RS0-RS15)

;      SSI Receive Slot Mask Register B
M_SSRSB EQU $FFFF          ; SSI Receive Slot Bits Mask B (RS16-RS31)

;-----
;
;      EQUATES for Exception Processing
;-----

;      Register Addresses

M_IPRC EQU $FFFFFF          ; Interrupt Priority Register Core
M_IPRP EQU $FFFFFFE         ; Interrupt Priority Register Peripheral

;      Interrupt Priority Register Core (IPRC)

M_IAL EQU $7                ; IRQA Mode Mask
M_IAL0 EQU 0                ; IRQA Mode Interrupt Priority Level (low)
M_IAL1 EQU 1                ; IRQA Mode Interrupt Priority Level (high)
M_IAL2 EQU 2                ; IRQA Mode Trigger Mode
M_IBL EQU $38               ; IRQB Mode Mask
M_IBL0 EQU 3                ; IRQB Mode Interrupt Priority Level (low)
M_IBL1 EQU 4                ; IRQB Mode Interrupt Priority Level (high)
M_IBL2 EQU 5                ; IRQB Mode Trigger Mode
M_ICL EQU $1C0              ; IRQC Mode Mask
M_ICL0 EQU 6                ; IRQC Mode Interrupt Priority Level (low)
M_ICL1 EQU 7                ; IRQC Mode Interrupt Priority Level (high)
M_ICL2 EQU 8                ; IRQC Mode Trigger Mode
M_IDL EQU $E00              ; IRQD Mode Mask
M_IDL0 EQU 9                ; IRQD Mode Interrupt Priority Level (low)
M_IDL1 EQU 10               ; IRQD Mode Interrupt Priority Level (high)

```

Preliminary Information

## Power Consumption Benchmark

---

```
M_IDL2 EQU 11           ; IRQD Mode Trigger Mode
M_D0L EQU $3000        ; DMA0 Interrupt priority Level Mask
M_D0L0 EQU 12          ; DMA0 Interrupt Priority Level (low)
M_D0L1 EQU 13          ; DMA0 Interrupt Priority Level (high)
M_D1L EQU $C000        ; DMA1 Interrupt Priority Level Mask
M_D1L0 EQU 14          ; DMA1 Interrupt Priority Level (low)
M_D1L1 EQU 15          ; DMA1 Interrupt Priority Level (high)
M_D2L EQU $30000       ; DMA2 Interrupt priority Level Mask
M_D2L0 EQU 16          ; DMA2 Interrupt Priority Level (low)
M_D2L1 EQU 17          ; DMA2 Interrupt Priority Level (high)
M_D3L EQU $C0000       ; DMA3 Interrupt Priority Level Mask
M_D3L0 EQU 18          ; DMA3 Interrupt Priority Level (low)
M_D3L1 EQU 19          ; DMA3 Interrupt Priority Level (high)
M_D4L EQU $300000      ; DMA4 Interrupt priority Level Mask
M_D4L0 EQU 20          ; DMA4 Interrupt Priority Level (low)
M_D4L1 EQU 21          ; DMA4 Interrupt Priority Level (high)
M_D5L EQU $C00000      ; DMA5 Interrupt priority Level Mask
M_D5L0 EQU 22          ; DMA5 Interrupt Priority Level (low)
M_D5L1 EQU 23          ; DMA5 Interrupt Priority Level (high)
```

```
;      Interrupt Priority Register Peripheral (IPRP)
```

```
M_HPL EQU $3           ; Host Interrupt Priority Level Mask
M_HPL0 EQU 0           ; Host Interrupt Priority Level (low)
M_HPL1 EQU 1           ; Host Interrupt Priority Level (high)
M_S0L EQU $C           ; SSI0 Interrupt Priority Level Mask
M_S0L0 EQU 2           ; SSI0 Interrupt Priority Level (low)
M_S0L1 EQU 3           ; SSI0 Interrupt Priority Level (high)
M_S1L EQU $30          ; SSI1 Interrupt Priority Level Mask
M_S1L0 EQU 4           ; SSI1 Interrupt Priority Level (low)
M_S1L1 EQU 5           ; SSI1 Interrupt Priority Level (high)
M_SCL EQU $C0          ; SCI Interrupt Priority Level Mask
M_SCL0 EQU 6           ; SCI Interrupt Priority Level (low)
M_SCL1 EQU 7           ; SCI Interrupt Priority Level (high)
M_T0L EQU $300         ; TIMER Interrupt Priority Level Mask
M_T0L0 EQU 8           ; TIMER Interrupt Priority Level (low)
M_T0L1 EQU 9           ; TIMER Interrupt Priority Level (high)
```

```
;-----
;
;      EQUATES for TIMER
;
;-----
```

```
;      Register Addresses Of TIMERO
```

### Preliminary Information

```
M_TCSR0 EQU $FFFF8F ; Timer 0 Control/Status Register
M_TLR0 EQU $FFFF8E ; TIMER0 Load Reg
M_T CPR0 EQU $FFFF8D ; TIMER0 Compare Register
M_T CR0 EQU $FFFF8C ; TIMER0 Count Register
```

```
; Register Addresses Of TIMER1
```

```
M_TCSR1 EQU $FFFF8B; TIMER1 Control/Status Register
M_TLR1 EQU $FFFF8A ; TIMER1 Load Reg
M_T CPR1 EQU $FFFF89 ; TIMER1 Compare Register
M_T CR1 EQU $FFFF88 ; TIMER1 Count Register
```

```
; Register Addresses Of TIMER2
```

```
M_TCSR2 EQU $FFFF87 ; TIMER2 Control/Status Register
M_TLR2 EQU $FFFF86 ; TIMER2 Load Reg
M_T CPR2 EQU $FFFF85 ; TIMER2 Compare Register
M_T CR2 EQU $FFFF84 ; TIMER2 Count Register
M_TPLR EQU $FFFF83 ; TIMER Prescaler Load Register
M_T PCR EQU $FFFF82 ; TIMER Prescaler Count Register
```

```
; Timer Control/Status Register Bit Flags
```

```
M_TE EQU 0 ; Timer Enable
M_TOIE EQU 1 ; Timer Overflow Interrupt Enable
M_TCIE EQU 2 ; Timer Compare Interrupt Enable
M_TC EQU $F0 ; Timer Control Mask (TC0-TC3)
M_INV EQU 8 ; Inverter Bit
M_TRM EQU 9 ; Timer Restart Mode
M_DIR EQU 11 ; Direction Bit
M_DI EQU 12 ; Data Input
M_DO EQU 13 ; Data Output
M_PCE EQU 15; Prescaled Clock Enable
M_TOF EQU 20 ; Timer Overflow Flag
M_TCF EQU 21 ; Timer Compare Flag
```

```
; Timer Prescaler Register Bit Flags
```

```
M_PS EQU $600000 ; Prescaler Source Mask
M_PS0 EQU 21
M_PS1 EQU 22
```

```
; Timer Control Bits
```

```
M_TC0 EQU 4 ; Timer Control 0
```

### Preliminary Information

## Power Consumption Benchmark

---

M\_TC1 EQU 5 ; Timer Control 1  
M\_TC2 EQU 6 ; Timer Control 2  
M\_TC3 EQU 7 ; Timer Control 3

-----  
;  
;  
;       EQUATES for Direct Memory Access (DMA)  
;  
-----

;       Register Addresses Of DMA  
M\_DSTR EQU FFFFF4     ; DMA Status Register  
M\_DOR0 EQU \$FFFFFF3 ; DMA Offset Register 0  
M\_DOR1 EQU \$FFFFFF2 ; DMA Offset Register 1  
M\_DOR2 EQU \$FFFFFF1 ; DMA Offset Register 2  
M\_DOR3 EQU \$FFFFFF0 ; DMA Offset Register 3

;       Register Addresses Of DMA0  
  
M\_DSR0 EQU \$FFFFEF ; DMA0 Source Address Register  
M\_DDR0 EQU \$FFFFEE ; DMA0 Destination Address Register  
M\_DCO0 EQU \$FFFFED ; DMA0 Counter  
M\_DCR0 EQU \$FFFFEC ; DMA0 Control Register

;       Register Addresses Of DMA1  
  
M\_DSR1 EQU \$FFFFEB ; DMA1 Source Address Register  
M\_DDR1 EQU \$FFFFEA ; DMA1 Destination Address Register  
M\_DCO1 EQU \$FFFFE9 ; DMA1 Counter  
M\_DCR1 EQU \$FFFFE8 ; DMA1 Control Register

;       Register Addresses Of DMA2  
  
M\_DSR2 EQU \$FFFFE7 ; DMA2 Source Address Register  
M\_DDR2 EQU \$FFFFE6 ; DMA2 Destination Address Register  
M\_DCO2 EQU \$FFFFE5 ; DMA2 Counter  
M\_DCR2 EQU \$FFFFE4 ; DMA2 Control Register

;       Register Addresses Of DMA4  
  
M\_DSR3 EQU \$FFFFE3 ; DMA3 Source Address Register  
M\_DDR3 EQU \$FFFFE2 ; DMA3 Destination Address Register  
M\_DCO3 EQU \$FFFFE1 ; DMA3 Counter  
M\_DCR3 EQU \$FFFFE0 ; DMA3 Control Register

## Preliminary Information

```

;      Register Addresses Of DMA4

M_DSR4 EQU $FFFFDF ; DMA4 Source Address Register
M_DDR4 EQU $FFFFDE ; DMA4 Destination Address Register
M_DC04 EQU $FFFFDD ; DMA4 Counter
M_DCR4 EQU $FFFFDC ; DMA4 Control Register

;      Register Addresses Of DMA5

M_DSR5 EQU $FFFFDB ; DMA5 Source Address Register
M_DDR5 EQU $FFFFDA ; DMA5 Destination Address Register
M_DC05 EQU $FFFFD9 ; DMA5 Counter
M_DCR5 EQU $FFFFD8 ; DMA5 Control Register

;      DMA Control Register

M_DSS EQU $3; DMA Source Space Mask (DSS0-DSS1)
M_DSS0 EQU 0; DMA Source Memory space 0
M_DSS1 EQU 1; DMA Source Memory space 1
M_DDS EQU $C; DMA Destination Space Mask (DDS-DDS1)
M_DDS0 EQU 2; DMA Destination Memory Space 0
M_DDS1 EQU 3; DMA Destination Memory Space 1
M_DAM EQU $3f0; DMA Address Mode Mask (DAM5-DAM0)
M_DAM0 EQU 4; DMA Address Mode 0
M_DAM1 EQU 5; DMA Address Mode 1
M_DAM2 EQU 6; DMA Address Mode 2
M_DAM3 EQU 7; DMA Address Mode 3
M_DAM4 EQU 8; DMA Address Mode 4
M_DAM5 EQU 9; DMA Address Mode 5
M_D3D EQU 10; DMA Three Dimensional Mode
M_DRS EQU $F800; DMA Request Source Mask (DRS0-DRS4)
M_DCON EQU 16; DMA Continuous Mode
M_DPR EQU $60000; DMA Channel Priority
M_DPR0 EQU 17; DMA Channel Priority Level (low)
M_DPR1 EQU 18; DMA Channel Priority Level (high)
M_DTM EQU $380000; DMA Transfer Mode Mask (DTM2-DTM0)
M_DTM0 EQU 19; DMA Transfer Mode 0
M_DTM1 EQU 20; DMA Transfer Mode 1
M_DTM2 EQU 21; DMA Transfer Mode 2
M_DI E EQU 22; DMA Interrupt Enable bit
M_DE EQU 23; DMA Channel Enable bit

;      DMA Status Register

M_DTD EQU $3F; Channel Transfer Done Status MASK (DTD0-DTD5)
M_DTD0 EQU 0 ; DMA Channel Transfer Done Status 0

```

---

**Preliminary Information**



## Power Consumption Benchmark

---

M\_DTD1 EQU 1 ; DMA Channel Transfer Done Status 1  
M\_DTD2 EQU 2 ; DMA Channel Transfer Done Status 2  
M\_DTD3 EQU 3 ; DMA Channel Transfer Done Status 3  
M\_DTD4 EQU 4 ; DMA Channel Transfer Done Status 4  
M\_DTD5 EQU 5; DMA Channel Transfer Done Status 5  
M\_DACT EQU 8; DMA Active State  
M\_DCH EQU \$E00; DMA Active Channel Mask (DCH0-DCH2)  
M\_DCH0 EQU 9; DMA Active Channel 0  
M\_DCH1 EQU 10; DMA Active Channel 1  
M\_DCH2 EQU 11 ; DMA Active Channel 2

-----  
;  
;  
; EQUATES for Phase Locked Loop (PLL)  
;  
-----

; Register Addresses Of PLL

M\_PCTL EQU \$FFFFFF ; PLL Control Register

; PLL Control Register

M\_MF EQU \$FFF : Multiplication Factor Bits Mask (MF0-MF11)  
M\_DF EQU \$7000 ; Division Factor Bits Mask (DF0-DF2)  
M\_XTLR EQU 15 ; XTAL Range select bit  
M\_XTLD EQU 16 ; XTAL Disable Bit  
M\_PSTP EQU 17 ; STOP Processing State Bit  
M\_PEN EQU 18 ; PLL Enable Bit  
M\_PCOD EQU 19 ; PLL Clock Output Disable Bit  
M\_PD EQU \$F00000; PreDivider Factor Bits Mask (PD0-PD3)

-----  
;  
;  
; EQUATES for BIU  
;  
-----

; Register Addresses Of BIU

M\_BCR EQU \$FFFFFFB; Bus Control Register  
M\_DCR EQU \$FFFFFFA; DRAM Control Register  
M\_AAR0 EQU \$FFFFFF9; Address Attribute Register 0

## Preliminary Information

```

M_AAR1 EQU $FFFFFF8; Address Attribute Register 1
M_AAR2 EQU $FFFFFF7; Address Attribute Register 2
M_AAR3 EQU $FFFFFF6; Address Attribute Register 3
M_IDR EQU $FFFFFF5 ; ID Register

;      Bus Control Register

M_BA0W EQU $1F; Area 0 Wait Control Mask (BA0W0-BA0W4)
M_BA1W EQU $3E0; Area 1 Wait Control Mask (BA1W0-BA1W4)
M_BA2W EQU $1C00; Area 2 Wait Control Mask (BA2W0-BA2W2)
M_BA3W EQU $E000; Area 3 Wait Control Mask (BA3W0-BA3W3)
M_BDFW EQU $1F0000 ; Default Area Wait Control Mask (BDFW0-BDFW4)
M_BBS EQU 21; Bus State
M_BLH EQU 22; Bus Lock Hold
M_BRH EQU 23; Bus Request Hold

;      DRAM Control Register

M_BCW EQU $3; In Page Wait States Bits Mask (BCW0-BCW1)
M_BRW EQU $C ; Out Of Page Wait States Bits Mask (BRW0-BRW1)
M_BPS EQU $300; DRAM Page Size Bits Mask (BPS0-BPS1)
M_BPLE EQU 11; Page Logic Enable
M_BME EQU 12; Mastership Enable
M_BRE EQU 13; Refresh Enable
M_BSTR EQU 14; Software Triggered Refresh
M_BRF EQU $7F8000; Refresh Rate Bits Mask (BRF0-BRF7)
M_BRP EQU 23; Refresh prescaler

;      Address Attribute Registers

M_BAT EQU $3 ; Ext. Access Type and Pin Def. Bits Mask (BAT0-BAT1)
M_BAAP EQU 2; Address Attribute Pin Polarity
M_BPEN EQU 3; Program Space Enable
M_BXEN EQU 4; X Data Space Enable
M_BYEN EQU 5; Y Data Space Enable
M_BAM EQU 6; Address Muxing
M_BPAC EQU 7; Packing Enable
M_BNC EQU $F00 ; Number of Address Bits to Compare Mask (BNC0-BNC3)
M_BAC EQU $FFF000; Address to Compare Bits Mask (BAC0-BAC11)

;      control and status bits in SR

M_CP EQU $c00000; mask for CORE DMA priority bits in SR
M_CA EQU 0; Carry
M_V EQU 1; Overflow
M_Z EQU 2; Zero

```

---

Preliminary Information

## Power Consumption Benchmark

---

M\_N EQU 3; Negative  
M\_U EQU 4; Unnormalized  
M\_E EQU 5; Extension  
M\_L EQU 6; Limit  
M\_S EQU 7; Scaling Bit  
M\_I0 EQU 8; Interupt Mask Bit 0  
M\_I1 EQU 9; Interupt Mask Bit 1  
M\_S0 EQU 10; Scaling Mode Bit 0  
M\_S1 EQU 11; Scaling Mode Bit 1  
M\_SC EQU 13; Sixteen\_Bit Compatibility  
M\_DM EQU 14; Double Precision Multiply  
M\_LF EQU 15; DO-Loop Flag  
M\_FV EQU 16; DO-Forever Flag  
M\_SA EQU 17; Sixteen-Bit Arithmetic  
M\_CE EQU 19; Instruction Cache Enable  
M\_SM EQU 20; Arithmetic Saturation  
M\_RM EQU 21; Rounding Mode  
M\_CP0 EQU 22; bit 0 of priority bits in SR  
M\_CP1 EQU 23; bit 1 of priority bits in SR  
  
; control and status bits in OMR  
M\_CDP EQU \$300; mask for CORE-DMA priority bits in OMR  
M\_MA EQU 0; Operating Mode A  
M\_MB EQU 1; Operating Mode B  
M\_MC EQU 2; Operating Mode C  
M\_MD EQU 3; Operating Mode D  
M\_EBD EQU 4; External Bus Disable bit in OMR  
M\_SD EQU 6; Stop Delay  
M\_MS EQU 7; Memory Switch bit in OMR  
M\_CDP0 EQU 8; bit 0 of priority bits in OMR  
M\_CDP1 EQU 9; bit 1 of priority bits in OMR  
M\_BEN EQU 10 ; Burst Enable  
M\_TAS EQU 11 ; TA Synchronize Select  
M\_BRT EQU 12; Bus Release Timing  
M\_ATE EQU 15; Address Tracing Enable bit in OMR.  
M\_XYS EQU 16; Stack Extension space select bit in OMR.  
M\_EUN EQU 17; Extended stack UNDERflow flag in OMR.  
M\_EOV EQU 18; Extended stack OVERflow flag in OMR.  
M\_WRP EQU 19; Extended WRaP flag in OMR.  
M\_SEN EQU 20; Stack Extension Enable bit in OMR.

## Preliminary Information

```

;*****
;
;   EQUATES for DSP56302A interrupts
;
;   Last update: June 11 1995
;
;*****

page 132,55,0,0,0
opt  mex

intequ ident 1,0

if @DEF(I_VEC)
;leave user definition as is.
else
I_VEC EQU $0
endif

;-----
; Non-Maskable interrupts
;-----
I_RESET EQU I_VEC+$00; Hardware RESET
I_STACK EQU I_VEC+$02; Stack Error
I_ILL EQU I_VEC+$04; Illegal Instruction
I_DBG EQU I_VEC+$06; Debug Request
I_TRAP EQU I_VEC+$08; Trap
I_NMI EQU I_VEC+$0A; Non Maskable Interrupt

;-----
; Interrupt Request Pins
;-----
I_IRQA EQU I_VEC+$10 ; IRQA
I_IRQB EQU I_VEC+$12 ; IRQB
I_IRQC EQU I_VEC+$14 ; IRQC
I_IRQD EQU I_VEC+$16 ; IRQD

;-----
; DMA Interrupts
;-----
I_DMA0 EQU I_VEC+$18 ; DMA Channel 0
I_DMA1 EQU I_VEC+$1A ; DMA Channel 1
I_DMA2 EQU I_VEC+$1C ; DMA Channel 2
I_DMA3 EQU I_VEC+$1E ; DMA Channel 3
I_DMA4 EQU I_VEC+$20 ; DMA Channel 4
I_DMA5 EQU I_VEC+$22 ; DMA Channel 5

```

### Preliminary Information

## Power Consumption Benchmark

---

```
;-----  
; Timer Interrupts  
;-----  
I_TIM0C EQU I_VEC+$24; TIMER 0 compare  
I_TIM0OF EQU I_VEC+$26; TIMER 0 overflow  
I_TIM1C EQU I_VEC+$28; TIMER 1 compare  
I_TIM1OF EQU I_VEC+$2A; TIMER 1 overflow  
I_TIM2C EQU I_VEC+$2C; TIMER 2 compare  
I_TIM2OF EQU I_VEC+$2E; TIMER 2 overflow  
  
;-----  
; ESSI Interrupts  
;-----  
I_SI0RD EQU I_VEC+$30; ESSIO Receive Data  
I_SI0RDE EQU I_VEC+$32; ESSIO Receive Data w/ exception Status  
I_SI0RLS EQU I_VEC+$34; ESSIO Receive last slot  
I_SI0TD EQU I_VEC+$36 ; ESSIO Transmit data  
I_SI0TDE EQU I_VEC+$38; ESSIO Transmit Data w/ exception Status  
I_SI0TLS EQU I_VEC+$3A; ESSIO Transmit last slot  
I_SI1RD EQU I_VEC+$40; ESSI1 Receive Data  
I_SI1RDE EQU I_VEC+$42; ESSI1 Receive Data w/ exception Status  
I_SI1RLS EQU I_VEC+$44 ; ESSI1 Receive last slot  
I_SI1TD EQU I_VEC+$46 ; ESSI1 Transmit data  
I_SI1TDE EQU I_VEC+$48; ESSI1 Transmit Data w/ exception Status  
I_SI1TLS EQU I_VEC+$4A; ESSI1 Transmit last slot  
  
;-----  
; SCI Interrupts  
;-----  
I_SCIRD EQU I_VEC+$50 ; SCI Receive Data  
I_SCIRDE EQU I_VEC+$52 ; SCI Receive Data With Exception Status  
I_SCITD EQU I_VEC+$54 ; SCI Transmit Data  
I_SCIIL EQU I_VEC+$56 ; SCI Idle Line  
I_SCITM EQU I_VEC+$58 ; SCI Timer  
  
;-----  
; HOST Interrupts  
;-----  
I_HRDF EQU I_VEC+$60 ; Host Receive Data Full  
I_HTDE EQU I_VEC+$62 ; Host Transmit Data Empty  
I_HC EQU I_VEC+$64 ; Default Host Command  
  
;-----  
; INTERRUPT ENDING ADDRESS  
;-----  
I_INTEND EQU I_VEC+$FF ; last address of interrupt vector space
```



### Preliminary Information



## Bootstrap Programs

---

```
; specifying the number of program words, 3 bytes specifying the address
; to start loading the program words and then 3 bytes for each program
; word to be loaded. The number of words, the starting address and the
; program words are received least significant byte first followed by the
; mid and then by the most significant byte. After receiving the
; program words, program execution starts in the same address where
; loading started. The SCI is programmed to work in asynchronous mode
; with 8 data bits, 1 stop bit and no parity. The clock source is
; external and the clock frequency must be 16x the baud rate.
; After each byte is received, it is echoed back through the SCI
; transmitter.
;
;
; ::::::::::::::::::::::::::::::::::::::::::::::::::::::::::::::::::::::::::::
; If MC:MB:MA=100, then it loads the program RAM from the Host
; Interface programmed to operate in the ISA mode.
; The HOST ISA bootstrap code expects to read a 24-bit word
; specifying the number of program words, a 24-bit word specifying the address
; to start loading the program words and then a 24-bit word for each program
; word to be loaded. The program words will be stored in
; contiguous PRAM memory locations starting at the specified starting address.
; After reading the program words, program execution starts from the same
; address where loading started.
; The Host Interface bootstrap load program may be stopped by
; setting the Host Flag 0 (HF0). This will start execution of the loaded
; program from the specified starting address.
;
;
; ::::::::::::::::::::::::::::::::::::::::::::::::::::::::::::::::::::::::::::
; If MC:MB:MA=101, then it loads the program RAM from the Host
; Interface programmed to operate in the HC11 non multiplexed mode.
;
; The HOST HC11 bootstrap code expects to read a 24-bit word
; specifying the number of program words, a 24-bit word specifying the address
; to start loading the program words and then a 24-bit word for each program
; word to be loaded. The program words will be stored in
; contiguous PRAM memory locations starting at the specified starting address.
; After reading the program words, program execution starts from the same
; address where loading started.
; The Host Interface bootstrap load program may be stopped by
; setting the Host Flag 0 (HF0). This will start execution of the loaded
; program from the specified starting address.
;
;
; ::::::::::::::::::::::::::::::::::::::::::::::::::::::::::::::::::::::::::::
; If MC:MB:MA=110, then it loads the program RAM from the Host
; Interface programmed to operate in the 8051 multiplexed bus mode,
```

### Preliminary Information

```

; in double-strobe pin configuration.
; The HOST 8051 bootstrap code expects accesses that are byte wide.
; The HOST 8051 bootstrap code expects to read 3 bytes forming a 24-bit word
; specifying the number of program words, 3 bytes forming a 24-bit word
; specifying the address to start loading the program words and then 3 bytes
; forming 24-bit words for each program word to be loaded.
; The program words will be stored in contiguous PRAM memory locations
; starting at the specified starting address.
; After reading the program words, program execution starts from the same
; address where loading started.
; The Host Interface bootstrap load program may be stopped by setting the
; Host Flag 0 (HF0). This will start execution of the loaded program from
; the specified starting address.
;
; The base address of the HI08 in multiplexed mode is 0x80 and is not modified
; by the bootstrap code. All the address lines are enabled and should be
; connected accordingly.
;
; ::::::::::::::::::::::::::::::::::::::::::::::::::::::::::::::::::::::::::::
; If MC:MB:MA=111, then it loads the program RAM from the Host
; Interface programmed to operate in the MC68302 bus mode,
; in single-strobe pin configuration.
; The HOST MC68302 bootstrap code expects accesses that are byte wide.
; The HOST MC68302 bootstrap code expects to read 3 bytes forming a 24-bit word
; specifying the number of program words, 3 bytes forming a 24-bit word
; specifying the address to start loading the program words and then 3 bytes
; forming 24-bit words for each program word to be loaded.
; The program words will be stored in contiguous PRAM memory locations
; starting at the specified starting address.
; After reading the program words, program execution starts from the same
; address where loading started.
; The Host Interface bootstrap load program may be stopped by setting the
; Host Flag 0 (HF0). This will start execution of the loaded program from
; the specified starting address.
;

BOOT    equ    $D00000    ; this is the location in P memory
                          ; on the external memory bus
                          ; where the external byte-wide
                          ; EPROM would be located
AARV    equ    $D00409    ; AAR1 selects the EPROM as CE~
                          ; mapped as P from $D00000 to
                          ; $DFFFFFF, active low

M_SSR   EQU     $FFFF93    ; SCI Status Register
M_STXL  EQU     $FFFF95    ; SCI Transmit Data Register (low)
M_SRXL  EQU     $FFFF98    ; SCI Receive Data Register (low)

```

Preliminary Information



## Bootstrap Programs

---

```
M_SCCR EQU    $FFFF9B      ; SCI Clock Control Register
M_SCR   EQU    $FFFF9C      ; SCI Control Register
M_PCRE  EQU    $FFFF9F      ; Port E Control register
M_AAR1  EQU    $FFFFFF8     ; Address Attribute Register 1
M_HPCR  EQU    $FFFFC4      ; Host Polarity Control Register
M_HSR   EQU    $FFFFC3      ; Host Status Register
M_HRX   EQU    $FFFFC6      ; Host Receive Register
HRDF    EQU    $0           ; Host Receive Data Full
HF0     EQU    $3           ; Host Flag 0
HEN     EQU    $6           ; Host Enable

        ORG PL:$ff0000,PL:$ff0000      ; bootstrap code starts at $ff0000

START
        clr a #$0a,X0           ; clear a and load X0 with constant 0a0000
        jclr #2,omr,EPRSCILD     ; If MC:MB:MA=0xx, go load from EPROM/SCI
        jclr #1,omr,OMR1ISO      ; If MC:MB:MA=10x, go to look for ISA/HCI1
                                   ; options
        jclr #0,omr,I8051HOSTLD ; If MC:MB:MA=110, go load from 8051 Host
        jmp  MC68302HOSTLD       ; If MC:MB:MA=111, go load from MC68302 Host
OMR1ISO
        jset #0,omr,HC11HOSTLD  ; If MC:MB:MA=101, go load from HC11 Host
                                   ; If MC:MB:MA=100, go load from ISA HOST

;=====
; This is the routine which loads a program through the HI08 host port
; The program is downloaded from the host MCU with the following scenario:
; 1) 3 bytes - Define the program length.
; 2) 3 bytes - Define the address to which to start loading the program to.
; 3) 3n bytes (while n is any integer number)
; The program words will be stored in contiguous PRAM memory locations starting
; at the specified starting address.
; After reading the program words, program execution starts from the same address
; where loading started.
; The host MCU may terminate the loading process by setting the HF1=0 and HF0=1.
; When the downloading is terminated, the program will start execution of the
; loaded program from the specified starting address.
; The HI08 boot ROM program enables the following busses to download programs
; through the HI08 port:
;
; 1 - ISA - Dual strobes non-multiplexed bus with negative strobe
; pulses dual positive request
; 2 - HCI1 - Single strobe non-multiplexed bus with positive strobe
; pulse single negative request.
; 4 - i8051 - Dual strobes multiplexed bus with negative strobe pulses
; dual negative request.
```

### Preliminary Information

```
; 5 - MC68302 - Single strobe non-multiplexed bus with negative strobe
; pulse single negative request.
;=====
```

ISAHOSTLD

```
movep #%0101000000011000,x:M_HPCR
; Configure the following conditions:
; HAP = 0 Negative host acknowledge
; HRP = 1 Positive host request
; HCSP = 0 Negative chip select input
; HD/HS = 1 Dual strobes bus (RD and WR strobes)
; HMUX = 0 Non multiplexed bus
; HASP = 0 (address strobe polarity has no meaning in non-multiplexed bus)
; HDSP = 0 Negative data strobes polarity
; HROD = 0 Host request is active when enabled spare = 0
; This bit should be set to 0 for future compatibility
; HEN = 0 When the HPCR register is modified HEN should be cleared
; HAEN = 0 Host acknowledge is disabled
; HREN = 1 Host requests are enabled
; HCSEN = 1 Host chip select input enabled
; HA9EN = 0 (address 9 enable bit has no meaning in non-multiplexed bus)
; HA8EN = 0 (address 8 enable bit has no meaning in non-multiplexed bus)
; HGEN = 0 Host GPIO pins are disabled
bra <HI08CONT
```

HC11HOSTLD

```
movep #%0000001000011000,x:M_HPCR
; Configure the following conditions:
; HAP = 0 Negative host acknowledge
; HRP = 0 Negative host request
; HCSP = 0 Negative chip select input
; HD/HS = 0 Single strobe bus (R/W~ and DS strobes)
; HMUX = 0 Non multiplexed bus
; HASP = 0 (address strobe polarity has no meaning in non-multiplexed bus)
; HDSP = 1 Negative data strobes polarity
; HROD = 0 Host request is active when enabled
; spare = 0 This bit should be set to 0 for future compatibility
; HEN = 0 When the HPCR register is modified HEN should be cleared
; HAEN = 0 Host acknowledge is disabled
; HREN = 1 Host requests are enabled
; HCSEN = 1 Host chip select input enabled
; HA9EN = 0 (address 9 enable bit has no meaning in non-multiplexed bus)
; HA8EN = 0 (address 8 enable bit has no meaning in non-multiplexed bus)
; HGEN = 0 Host GPIO pins are disabled
bra <HI08CONT
```

I8051HOSTLD

```
movep #%0001110000011110,x:M_HPCR
; Configure the following conditions:
```

Preliminary Information

## Bootstrap Programs

---

```
; HAP = 0 Negative host acknowledge
; HRP = 0 Negative host request
; HCSP = 0 Negative chip select input
; HD/HS = 1 Dual strobes bus (RD and WR strobes)
; HMUX = 1 Multiplexed bus
; HASP = 1 Positive address strobe polarity
; HDSP = 0 Negative data strobes polarity
; HROD = 0 Host request is active when enabled spare = 0
; This bit should be set to 0 for future compatibility
; HEN = 0 When the HPCR register is modified HEN should be cleared
; HAEN = 0 Host acknowledge is disabled
; HREN = 1 Host requests are enabled
; HCSEN = 1 Host chip select input enabled
; HA9EN = 1 Enable address 9 input
; HA8EN = 1 Enable address 8 input
; HGEN = 0 Host GPIO pins are disabled
bra <HI08CONT
MC68302HOSTLD
movep #00000000000111000,x:M_HPCR
; Configure the following conditions:
; HAP = 0 Negative host acknowledge
; HRP = 0 Negative host request
; HCSP = 0 Negative chip select input
; HD/HS = 0 Single strobe bus (R/W~ and DS strobes)
; HMUX = 0 Non multiplexed bus
; HASP = 0 (address strobe polarity has no meaning in non-multiplexed bus)
; HDSP = 0 Negative data strobes polarity
; HROD = 0 Host request is active when enabled spare = 0
; This bit should be set to 0 for future compatibility
; HEN = 0 When the HPCR register is modified HEN should be cleared
; HAEN = 1 Host acknowledge is enabled
; HREN = 1 Host requests are enabled
; HCSEN = 1 Host chip select input enabled
; HA9EN = 0 (address 9 enable bit has no meaning in non-multiplexed bus)
; HA8EN = 0 (address 8 enable bit has no meaning in non-multiplexed bus)
; HGEN = 0 Host GPIO pins are disabled
HI08CONT
bset #HEN,x:M_HPCR ; Enable the HI08 to operate as host interface
; (set HEN=1)
jclr #HRDF,x:M_HSR,* ; wait for the program length to be written
movep x:M_HRX,a0
jclr #HRDF,x:M_HSR,* ; wait for the program starting address
; to be written
movep x:M_HRX,r0
move r0,r1
do a0,HI08LOOP ; set a loop with the downloaded length counts
```

### Preliminary Information

```

HI08LL
    jset    #RDRF,x:M_HSR,HI08NW ; If new word was loaded then jump
                                           ;to read that word
    jclr    #HF0,x:M_HSR,HI08LL ; If HF0=0 then continue with the downloading
    enddo   ; Must terminate the do loop
    bra     <HI08LOOP
HI08NW
    movep   x:M_HRX,p:(r0)+ ; Move the new word into its destination
                                           ; location in the program RAM
HI08LOOP
    bra     <FINISH
;=====
EPRSCILD
    jclr    #1,omr,EPROMLD ; If MC:MB:MA=001, go load from EPROM
;=====
; This is the routine that loads from the SCI.
; MC:MB:MA=010 - external SCI clock

SCILD
    movep   #$0302,X:M_SCR ; Configure SCI Control Reg
    movep   #$C000,X:M_SCCR ; Configure SCI Clock Control Reg
    movep   #7,X:M_PCRE ; Configure SCLK, TXD and RXD

    do #6,_LOOP6 ; get 3 bytes for number of program words and
                                           ; 3 bytes for the starting address
    jclr    #2,X:M_SSR,* ; Wait for RDRF to go high
    movep   X:M_SRXL,A2 ; Put 8 bits in A2
    jclr    #1,X:M_SSR,* ; Wait for TDRE to go high
    movep   A2,X:M_STXL ; echo the received byte
    asr    #8,a,a
_LOOP6
    move    a1,r0 ; starting address for load
    move    a1,r1 ; save starting address

    do a0,_LOOP7 ; Receive program words
    do #3, LOOP8
    jclr    #2,X:M_SSR,* ; Wait for RDRF to go high
    movep   X:M_SRXL,A2 ; Put 8 bits in A2
    jclr    #1,X:M_SSR,* ; Wait for TDRE to go high
    movep   a2,X:M_STXL ; echo the received byte
    asr    #8,a,a
_LOOP8
    movem   a1,p:(r0)+ ; Store 24-bit result in P mem.
_LOOP7
    bra     <FINISH ; Boot from SCI done

```

Preliminary Information

## Bootstrap Programs

---

```
;=====
; This is the routine that loads from external EPROM.
; MC:MB:MA=001

EPROMLD
    move #BOOT,r2          ; r2 = address of external EPROM
    movep #AARV,X:M_AAR1  ; aar1 configured for SRAM types of access

    do #6,_LOOP9          ; read number of words and starting address
    movem p:(r2)+,a2      ; Get the 8 LSB from ext. P mem.
    asr #8,a,a            ; Shift 8 bit data into A1
_LOOP9
    move a1,r0             ; starting address for load
    move a1,r1             ; save it in r1
                           ; a0 holds the number of words

    do a0,_LOOP10         ; read program words
    do #3,_LOOP11         ; Each instruction has 3 bytes
    movem p:(r2)+,a2      ; Get the 8 LSB from ext. P mem.
    asr #8,a,a            ; Shift 8 bit data into A1
_LOOP11
    movem a1,p:(r0)+      ; Store 24-bit result in P mem.
_LOOP10
                           ; and go get another 24-bit word.
                           ; Boot from EPROM done
;=====
FINISH

; This is the exit handler that returns execution to normal
; expanded mode and jumps to the RESET vector.

    andi #$0,ccr          ; Clear CCR as if RESET to 0.
    jmp (r1)              ; Then go to starting Prog addr.

; End of bootstrap code. Number of program words: 91
```



### Preliminary Information

# INDEX

---

## A

ac electrical characteristics 2-4  
address bus 1-1  
Address Trace mode iv  
address, electronic mail ii  
ALU iii  
applications v  
arbitration bus timings 2-56  
Arithmetic Logic Unit iii

## B

benchmark test algorithm A-1  
bootstrap ROM iv  
boundary scan (JTAG) timing diagram 2-79  
bus  
    address 1-2  
    data 1-2  
    external address 1-6  
    external data 1-6  
    multiplexed 1-2  
    non-multiplexed 1-2  
bus acquisition timings 2-57  
bus control 1-1  
bus release timings 2-58, 2-59

## C

Clock 1-5  
clock 1-1  
    external 2-5  
    operation 2-7  
clocks  
    internal 2-5  
contents ii  
crystal oscillator circuits 2-6

## D

Data Arithmetic Logic Unit iii  
data bus 1-1  
data memory expansion iv  
dc electrical characteristics 2-3  
Debug support iv  
description, general i  
design considerations

    electrical 4-3  
    PLL 4-5, 4-6  
    power consumption 4-4  
    thermal 4-1, 4-2  
Direct Memory Access iii  
DMA iii  
document conventions ii  
documentation list vi  
Double Data Strobe 1-2  
DRAM  
    out of page  
        read access 2-49  
        Wait states selection guide 2-37  
        write access 2-50  
    out of page and refresh timings  
        11 Wait states 2-43  
        15 Wait states 2-46  
        4 Wait states 2-37  
        8 Wait states 2-40  
    Page mode  
        read accesses 2-36  
        Wait states selection guide 2-26  
        write accesses 2-35  
    Page mode timings  
        1 Wait state 2-27  
        2 Wait states 2-29  
        3 Wait states 2-31  
        4 Wait states 2-33  
    refresh access 2-51  
DRAM controller iv  
DS 1-2  
DSP56300  
    core features iii  
    Family Manual vi  
DSP56302  
    User's Manual vi  
DSP56302A  
    block diagram i  
    description i  
    features iii  
    specifications 2-1  
    Technical Data vi

## Preliminary Information

**E**

- electrical design considerations 4-3
- Enhanced Synchronous Serial Interface 1-1, 1-16
- Enhanced Synchronous Serial Interfaces v
- ESSI v, 1-1, 1-2, 1-16
  - receiver timing 2-74
  - timings 2-70
  - transmitter timing 2-73
- External 2-21
- external address bus 1-6
- external bus control 1-6, 1-7, 1-8
- external bus synchronous timings (SRAM access) 2-52
- external clock operation 2-5
- external data bus 1-6
- external interrupt timing (negative edge-triggered) 2-18
- external level-sensitive fast interrupt timing 2-18
- external memory access (DMA Source) timing 2-20
- external memory expansion port 1-6
- External Memory Interface (Port A) 2-21

**F**

- functional groups 1-2
- functional signal groups 1-1

**G**

- general description i
- General Purpose Input/Output v
- GPIO v, 1-2
  - Timers 1-2
- GPIO timing 2-77
- Ground 1-4
  - PLL 1-4
- ground 1-1

**H**

- helpline electronic mail (email) address ii
- HI08 v, 1-1, 1-2, 1-11, 1-12, 1-13, 1-14, 1-15
- Host Interface 1-1
- Host Interface v, 1-2, 1-11, 1-12, 1-13, 1-14, 1-15
- Host Interface timing 2-60
- host port
  - configuration 1-12
  - usage considerations 1-11
- Host Request
  - Double 1-2

- Single 1-2
- HR 1-2

**I**

- information sources vi
- instruction cache iv
- internal clocks 2-5
- internet address ii
- interrupt and mode control 1-1, 1-9
- interrupt control 1-9
- interrupt timing 2-10
  - external level-sensitive fast 2-18
  - external negative edge-triggered 2-18
  - synchronous from Wait state 2-19

**J**

- JTAG iv
- JTAG reset timing diagram 2-80
- JTAG timing 2-78

**M**

- maximum ratings 2-1, 2-2
- memory expansion port iv
- mode control 1-9
- Mode select timing 2-10
- multiplexed bus 1-2
- multiplexed bus timings
  - read 2-65
  - write 2-66

**N**

- non-multiplexed bus 1-2
- non-multiplexed bus timings
  - read 2-63
  - write 2-64

**O**

- off-chip memory iv
- OnCE
  - Debug request 2-80
  - module timing 2-80
- OnCE module iv
- OnCE/JTAG 1-2
- OnCE/JTAG port 1-1
- on-chip DRAM controller iv
- On-Chip Emulation module iv
- on-chip memory iv
- operating mode select timing 2-19
- ordering information 5-1

---

**Preliminary Information**

**P**

package  
 144-pin TQFP 3-1  
 196-pin PBGA 3-1  
 PBGA description 3-10, 3-11, 3-12, 3-15, 3-19  
 TQFP description 3-2, 3-3, 3-4, 3-6, 3-9  
 PBGA 3-1  
 ball grid drawing (bottom) 3-11  
 ball grid drawing (top) 3-10  
 ball list by name 3-15  
 ball list by number 3-12  
 mechanical drawing 3-19  
 PCU iii  
 Phase Lock Loop iii, 2-9  
 PLL iii, 1-1, 1-5, 2-9  
 Characteristics 2-9  
 performance issues 4-5  
 PLL design considerations 4-5, 4-6  
 PLL performance issues 4-6  
 Port A 1-1, 1-6, 2-21  
 Port B 1-1, 1-2, 1-14  
 Port C 1-1, 1-2, 1-16  
 Port D 1-1, 1-2  
 Port E 1-1  
 Power 1-3  
 power 1-1  
 power consumption benchmark test A-1  
 power consumption design considerations 4-4  
 power management v  
 Program Control Unit iii  
 program memory expansion iv  
 program RAM iv

**R**

recovery from Stop state using  $\overline{\text{IRQA}}$  2-19, 2-20  
 RESET 1-9  
 Reset timing 2-10, 2-17  
 synchronous 2-17  
 ROM, bootstrap iv

**S**

SCI v, 1-2  
 Asynchronous mode timing 2-69  
 Synchronous mode timing 2-69  
 timing 2-67  
 Serial Communications Interface v  
 Serial Communications Interface (SCI) 1-1  
 signal groupings 1-1

signals 1-1  
 functional grouping 1-2  
 Single Data Strobe 1-2  
 SRAM 2-54  
 Access 2-52  
 read access 2-25  
 read and write accesses 2-21  
 support iv  
 write access 2-25  
 Stop mode v  
 Stop state  
 recovery from 2-19, 2-20  
 Stop timing 2-10  
 supply voltage 2-2  
 Switch mode iv  
 synchronous bus timings  
 SRAM  
 2 WS 2-55  
 SRAM 1 WS (BCR controlled) 2-54  
 synchronous interrupt from Wait state timing 2-19  
 synchronous Reset timing 2-17

**T**

table of contents ii  
 TAP iv  
 target applications v  
 technical assistance ii  
 Test Access Port iv  
 Test Access Port timing diagram 2-79  
 Test Clock (TCLK) input timing diagram 2-78  
 thermal characteristics 2-2  
 thermal design considerations 4-1, 4-2  
 Timer  
 event input restrictions 2-75  
 interrupt generation 2-76  
 timing 2-75  
 Timers 1-1, 1-2  
 timing  
 interrupt 2-10  
 mode select 2-10  
 Reset 2-10  
 Stop 2-10  
 TQFP 3-1  
 mechanical drawing 3-9  
 pin list by name 3-6  
 pin list by number 3-4  
 pin-out drawing (bottom) 3-3  
 pin-out drawing (top) 3-2

**Preliminary Information**



## Index

---

### W

Wait mode v  
World Wide Web vi

### X

X data RAM iv

### Y

Y data RAM iv

OnCE and Mfax are trademarks of Motorola, Inc.



Motorola reserves the right to make changes without further notice to any products herein. Motorola makes no warranty, representation or guarantee regarding the suitability of its products for any particular purpose, nor does Motorola assume any liability arising out of the application or use of any product or circuit, and specifically disclaims any and all liability, including without limitation consequential or incidental damages. "Typical" parameters which may be provided in Motorola data sheets and/or specifications can and do vary in different applications and actual performance may vary over time. All operating parameters, including "Typicals" must be validated for each customer application by customer's technical experts. Motorola does not convey any license under its patent rights nor the rights of others. Motorola products are not designed, intended, or authorized for use as components in systems intended for surgical implant into the body, or other applications intended to support life, or for any other application in which the failure of the Motorola product could create a situation where personal injury or death may occur. Should Buyer purchase or use Motorola products for any such unintended or unauthorized application, Buyer shall indemnify and hold Motorola and its officers, employees, subsidiaries, affiliates, and distributors harmless against all claims, costs, damages, and expenses, and reasonable attorney fees arising out of, directly or indirectly, any claim of personal injury or death associated with such unintended or unauthorized use, even if such claim alleges that Motorola was negligent regarding the design or manufacture of the part. Motorola and  are registered trademarks of Motorola, Inc. Motorola, Inc. is an Equal Opportunity/Affirmative Action Employer.

How to reach us:

**USA/Europe/Locations Not Listed:**

Motorola Literature Distribution  
P.O. Box 5405  
Denver, Colorado 80217  
303-675-2140  
1 (800) 441-2447

**Asia/Pacific:**

Motorola Semiconductors H.K. Ltd.  
8B Tai Ping Industrial Park  
51 Ting Kok Road  
Tai Po, N.T., Hong Kong  
852-26629298

**Japan:**

Nippon Motorola Ltd.  
SPD, Strategic Planning Office  
4-32-1, Nishi-Gotanda  
Shinagawa-ku, Tokyo 141, Japan  
81-3-5487-8488

**Mfax™:**

RMFAX0@email.sps.mot.com  
TOUCHTONE (602) 244-6609  
US & Canada ONLY (800) 774-1848

**Technical Resource Center:**

1 (800) 521-6274

**DSP Helpline**

dsphelp@dsp.sps.mot.com

**Internet:**

<http://www.motorola-dsp.com>

