



16,384 x 4 Static RAM  
Separate I/O

Features

- Ultra high speed  
— 8 ns  $t_{AA}$
- Low active power  
— 700 mW
- Low standby power  
— 250 mW
- Transparent write (7B161)
- BiCMOS for optimum speed/power
- TTL-compatible inputs and outputs
- Capable of withstanding greater than 2001V electrostatic discharge.

Functional Description

The CY7B161 and CY7B162 are high-performance BiCMOS static RAMs organized as 16,384 by 4 bits with separate I/O. Easy memory expansion is provided by active LOW chip enables ( $CE_1$ ,  $CE_2$ ) and three-state drivers. They have a CE power-down feature, reducing the power consumption by 67% when deselected.

Writing to the device is accomplished when the chip enable ( $CE_1$ ,  $CE_2$ ) and write enable ( $WE$ ) inputs are all LOW. Data on the four input pins ( $I_0$  through  $I_3$ ) is written

into the memory location specified on the address pins ( $A_0$  through  $A_{13}$ ).

Reading the device is accomplished by taking the chip enables ( $CE_1$ ,  $CE_2$ ) and  $OE$  LOW, while write enable ( $WE$ ) remains HIGH. Under these conditions, the contents of the memory location specified on the address pins will appear on the four data output pins ( $O_0$  through  $O_3$ ).

The output pins remain in high-impedance state when write enable ( $WE$ ) is LOW (7B162 only), or one of the chip enables ( $CE_1$ ,  $CE_2$ ) is HIGH, or  $OE$  is HIGH.

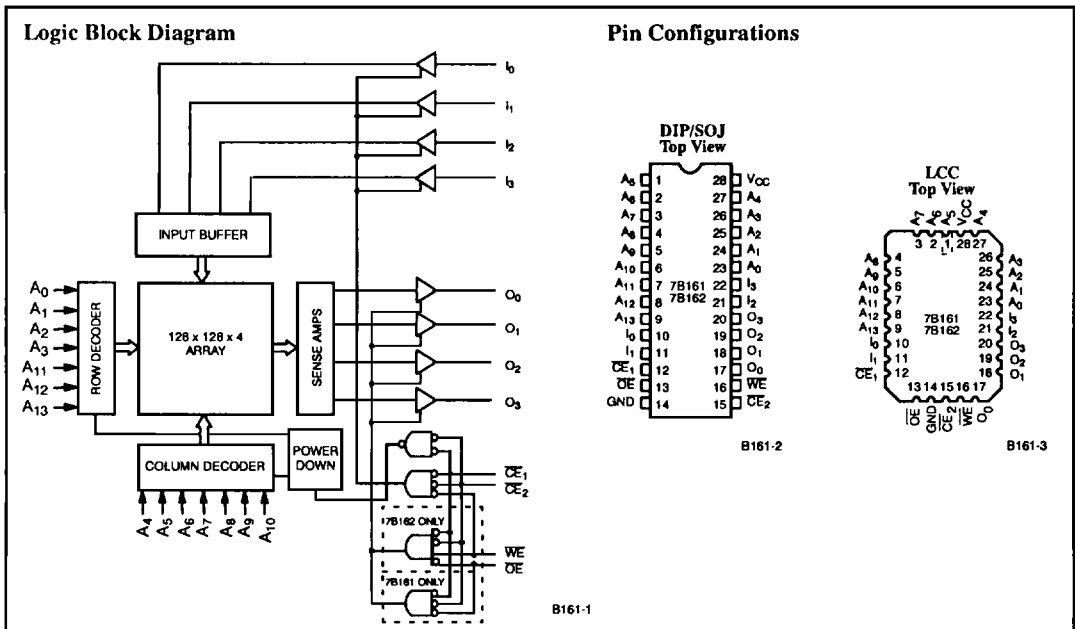

Selection Guide

		7B161-8 7B162-8	7B161-10 7B162-10	7B161-12 7B162-12	7B161-15 7B162-15
Maximum Access Time (ns)		8	10	12	15
Maximum Operating Current (mA)	Commercial	140	130	120	
	Military		145	140	135
Maximum Standby Current (mA)	Commercial	50	40	40	
	Military		60	55	50

Shaded area contains preliminary information.

### Maximum Ratings

(Above which the useful life may be impaired. Exposure to absolute maximum rated conditions for extended periods may affect device reliability. For user guidelines, not tested.)

Storage Temperature	- 65°C to +150°C
Ambient Temperature with Power Applied	- 55°C to +125°C
Supply Voltage to Ground Potential	- 0.5V to +7.0V
DC Voltage Applied to Outputs in High Z State	- 0.5V to +7.0V
DC Input Voltage <sup>[1]</sup>	- 3.0V to +7.0V

Output Current into Outputs (Low)	20 mA
Latch-Up Current	> 200 mA
Static Discharge Voltage (per MIL-STD-883, Method 3015)	> 2001V

### Operating Range

Range	Ambient Temperature	V <sub>CC</sub>	
		-8	-10, -12
Commercial	0°C to +70°C	5V ± 5%	5V ± 10%
Military <sup>[2]</sup>	- 55°C to +125°C	5V ± 10%	

### Electrical Characteristics Over the Operating Range<sup>[3]</sup>

Parameters	Description	Test Conditions	7B161-8 7B162-8		7B161-10 7B162-10		Units	
			Min.	Max.	Min.	Max.		
V <sub>OH</sub>	Output HIGH Voltage	V <sub>CC</sub> = Min., I <sub>OH</sub> = - 4.0 mA I <sub>OH</sub> = - 2.0 mA	Com'l	2.4		2.4	V	
			Mil	2.4		2.4		
V <sub>OL</sub>	Output LOW Voltage	V <sub>CC</sub> = Min., I <sub>OL</sub> = 8.0 mA		0.4		0.4	V	
V <sub>IH</sub>	Input HIGH Level		2.2	V <sub>CC</sub>	2.2	V <sub>CC</sub>	V	
V <sub>IL</sub>	Input LOW Voltage <sup>[1]</sup>		- 0.5	0.8	- 0.5	0.8	V	
I <sub>IX</sub>	Input Load Current	GND ≤ V <sub>I</sub> ≤ V <sub>CC</sub>	- 10	+10	- 10	+10	μA	
I <sub>OZ</sub>	Output Leakage Current	GND ≤ V <sub>I</sub> ≤ V <sub>CC</sub> , Output Disabled	- 10	+10	- 10	+10	μA	
I <sub>CC</sub>	V <sub>CC</sub> Operating Supply Current	V <sub>CC</sub> = Max., I <sub>OUT</sub> = 0 mA, f = f <sub>max</sub>	Com'l		140		130	mA
			Mil				145	
I <sub>SB</sub>	Automatic CE Power-Down Current	CE ≥ V <sub>IH</sub> , I <sub>OUT</sub> = 0 mA	Com'l		50		40	mA
			Mil				60	

Shaded area contains preliminary information.

Parameters	Description	Test Conditions	7B161-12 7B162-12		7B161-15 7B162-15		Units	
			Min.	Max.	Min.	Max.		
V <sub>OH</sub>	Output HIGH Voltage	V <sub>CC</sub> = Min., I <sub>OH</sub> = - 4.0 mA I <sub>OH</sub> = - 2.0 mA	Com'l	2.4		2.4	V	
			Mil	2.4		2.4		
V <sub>OL</sub>	Output LOW Voltage	V <sub>CC</sub> = Min., I <sub>OL</sub> = 8.0 mA		0.4		0.4	V	
V <sub>IH</sub>	Input HIGH Level		2.2	V <sub>CC</sub>	2.2	V <sub>CC</sub>	V	
V <sub>IL</sub>	Input LOW Voltage <sup>[1]</sup>		- 0.5	0.8	- 0.5	0.8	V	
I <sub>IX</sub>	Input Load Current	GND ≤ V <sub>I</sub> ≤ V <sub>CC</sub>	- 10	+10	- 10	+10	μA	
I <sub>OZ</sub>	Output Leakage Current	GND ≤ V <sub>I</sub> ≤ V <sub>CC</sub> , Output Disabled	- 10	+10	- 10	+10	μA	
I <sub>CC</sub>	V <sub>CC</sub> Operating Supply Current	V <sub>CC</sub> = Max., I <sub>OUT</sub> = 0 mA, f = f <sub>max</sub>	Com'l		120			mA
			Mil		140		135	
I <sub>SB</sub>	Automatic CE Power-Down Current	CE ≥ V <sub>IH</sub> , I <sub>OUT</sub> = 0 mA	Com'l		40			mA
			Mil		55		50	

### Capacitance<sup>[4]</sup>

Parameters	Description	Test Conditions	Max. <sup>[5]</sup>	Units
C <sub>IN</sub>	Input Capacitance	T <sub>A</sub> = 25°C, f = 1 MHz, V <sub>CC</sub> = 5.0V	6	pF
C <sub>OUT</sub>	Output Capacitance		6	pF

#### Notes:

- V<sub>IL</sub> (min.) = - 3.0V for pulse width < 20 ns.
- T<sub>A</sub> is the "instant on" case temperature.
- See the last page of this specification for Group A subgroup testing information.
- Tested initially and after any design or process changes that may affect these parameters.
- For all packages except CerDIP (D22), which has maximums of C<sub>IN</sub> = 9.5 pF and C<sub>OUT</sub> = 9 pF.

### AC Test Loads and Waveforms

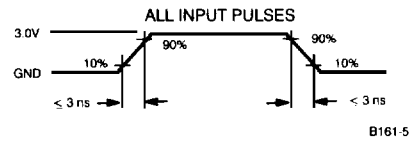
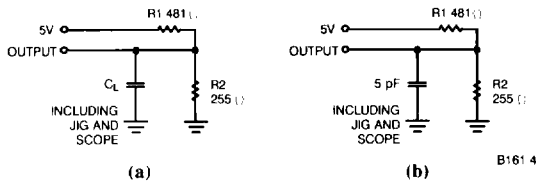

Equivalent to: THEVENIN EQUIVALENT

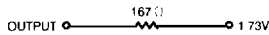

### Switching Characteristics Over the Operating Range<sup>[3, 6, 7]</sup>

Parameters	Description	7B161-8 7B162-8		7B161-10 7B162-10		7B161-12 7B162-12		7B161-15 7B162-15		Units
		Min.	Max.	Min.	Max.	Min.	Max.	Min.	Max.	
<b>READ CYCLE</b>										
$t_{RC}$	Read Cycle Time	8		10		12		15		ns
$t_{AA}$	Address to Data Valid		8		10		12		15	ns
$t_{OHA}$	Output Hold from Address Change	2.5		3		3		3		ns
$t_{ACE}$	$\overline{CE}$ LOW to Data Valid		8		10		12		15	ns
$t_{DOE}$	$\overline{OE}$ LOW to Data Valid		4.2		5		6		8	ns
$t_{LZOE}$	$\overline{OE}$ LOW to Low Z <sup>[8]</sup>	1.5		2		2		3		ns
$t_{HZOE}$	$\overline{OE}$ HIGH to High Z <sup>[9]</sup>		4		5		6		7	ns
$t_{LZCE}$	$\overline{CE}$ LOW to Low Z <sup>[8]</sup>	2		2		2		3		ns
$t_{HZCE}$	$\overline{CE}$ HIGH to High Z <sup>[8, 9]</sup>		4		5		6		7	ns
<b>WRITE CYCLE<sup>[10]</sup></b>										
$t_{WC}$	Write Cycle Time	8		10		12		15		ns
$t_{SCE}$	$\overline{CE}$ LOW to Write End	7		8		8		10		ns
$t_{AW}$	Address Set-Up to Write End	7		8		8		10		ns
$t_{HIA}$	Address Hold from Write End	0		0		0		0		ns
$t_{SA}$	Address Set-Up to Write Start	0		0		0		0		ns
$t_{PWE}$	$\overline{WE}$ Pulse Width	6.5		8		8		10		ns
$t_{SD}$	Data Set-Up to Write End	4		5		6		7		ns
$t_{HD}$	Data Hold from Write End	0		0		0		0		ns
$t_{LZWE}$	$\overline{WE}$ HIGH to Low Z <sup>[8]</sup> (7B162)	2		2		2		3		ns
$t_{HZWE}$	$\overline{WE}$ LOW to High Z <sup>[8, 9]</sup> (7B162)		4		5		6		7	ns
$t_{AWE}$	$\overline{WE}$ LOW to Data Valid (7B161)		8		10		12		15	ns
$t_{ADV}$	Data Valid to Output Valid (7B161)		8		10		12		15	ns

**Notes:**

- Test conditions assume signal transition time of 3 ns or less, timing reference levels of 1.5V, input pulse levels of 0 to 3.0V, and output loading of the specified  $I_{OL}/I_{OH}$  and  $C_L = 20$  pF.
- Both  $CE_1$  and  $CE_2$  are represented by  $\overline{CE}$  in the Switching Characteristics and Waveforms section.
- At any given temperature and voltage condition,  $t_{LZ}$  is less than  $t_{LZ}$  for any given device. This parameter is guaranteed and not 100% tested.
- $t_{HZCE}$ ,  $t_{HZOE}$ , and  $t_{HZWE}$  are specified with  $C_L = 5$  pF as in part (b) of AC Test Loads. Transition is measured  $\pm 200$  mV from steady state voltage. This parameter is guaranteed and not 100% tested.
- The internal write time of the memory is defined by the overlap of  $CE_1$  LOW,  $CE_2$  LOW, and  $WE$  LOW. Both signals must be LOW to initiate a write and either signal can terminate a write by going HIGH. The data input set-up and hold timing should be referenced to the rising edge of the signal that terminates the write.

Switching Waveforms<sup>[7]</sup>

Read Cycle No. 1<sup>[11, 12]</sup>

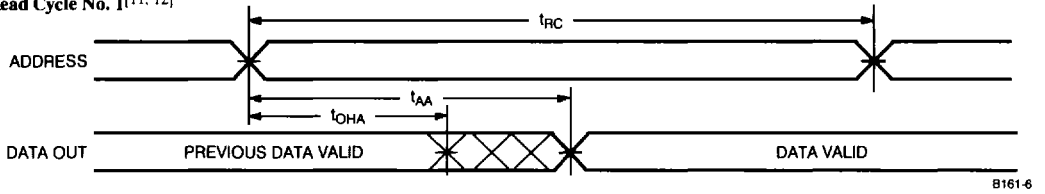

Read Cycle No. 2<sup>[11, 13]</sup>

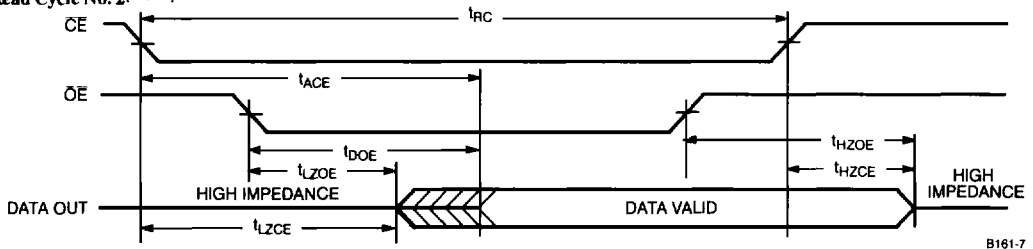

Write Cycle No. 1 ( $\overline{WE}$  Controlled)<sup>[10]</sup>

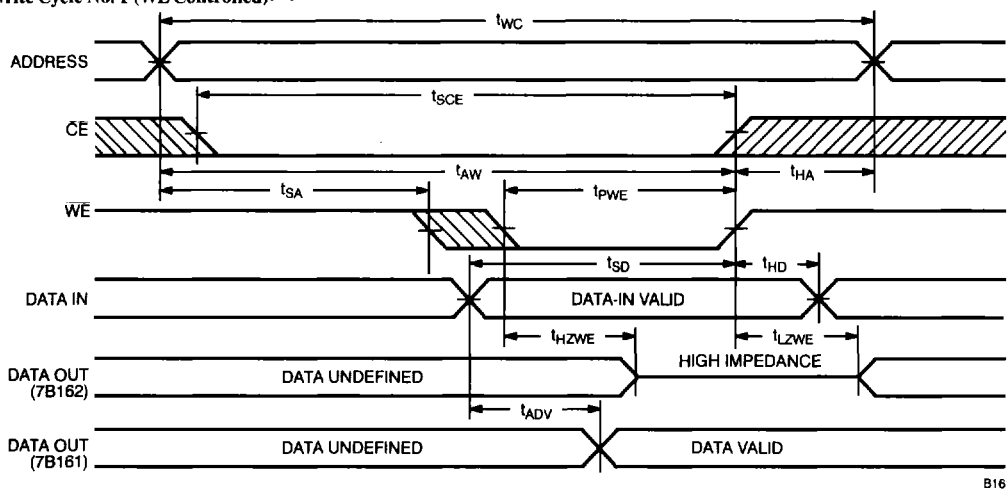

Notes:

11.  $\overline{WE}$  is HIGH for read cycle.
12. Device is continuously selected,  $\overline{CE}_1, \overline{CE}_2 \leq V_{IL}$ .  $\overline{OE} < V_{IL}$ , also.
13. Address valid prior to or coincident with  $\overline{CE}_1$  and  $\overline{CE}_2$  transition LOW.

Switching Waveforms<sup>[7]</sup>(continued)

Write Cycle No. 2 ( $\overline{CE}$  Controlled)<sup>[10,14]</sup>

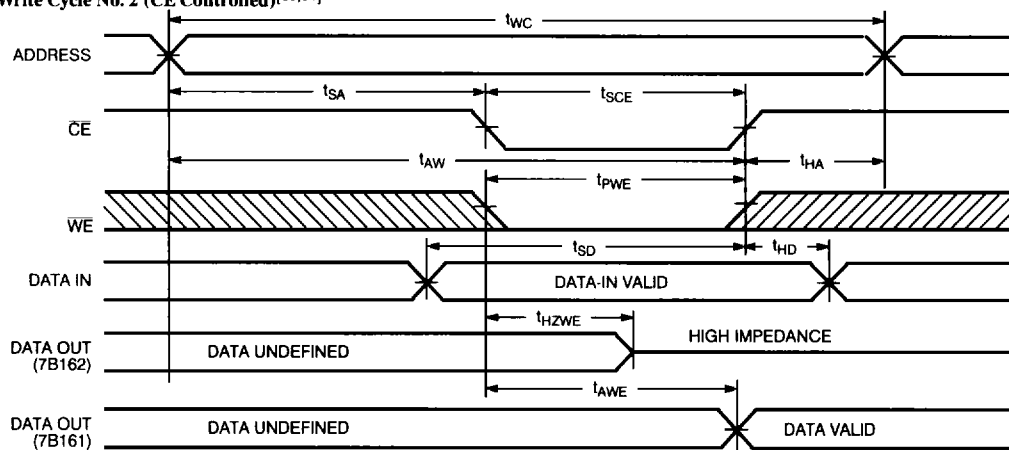

B161-9

Note:

14. If  $\overline{CE}$  goes HIGH simultaneously with  $\overline{WE}$  HIGH, the output remains in a high-impedance state (7B162 only).

7B161 Truth Table

CE <sub>1</sub>	CE <sub>2</sub>	WE	OE	Outputs	Inputs	Mode
H	X	X	X	High Z	X	Deselect/Power-Down
X	H	X	X	High Z	X	Deselect/Power-Down
L	L	H	L	Data Out	X	Read
L	L	L	L	Data In	Data In	Write
L	L	L	H	High Z	Data In	Write
L	L	H	H	High Z	X	Deselect

7B162 Truth Table

CE <sub>1</sub>	CE <sub>2</sub>	WE	OE	Outputs	Inputs	Mode
H	X	X	X	High Z	X	Deselect/Power-Down
X	H	X	X	High Z	X	Deselect/Power-Down
L	L	H	L	Data Out	X	Read
L	L	L	X	High Z	Data In	Write
L	L	H	H	High Z	X	Deselect

### Ordering Information

Speed (ns)	Ordering Code	Package Type	Operating Range
8	CY7B161-8DC	D22	Commercial
	CY7B161-8PC	P21	
	CY7B161-8VC	V21	
10	CY7B161-10DC	D22	Commercial
	CY7B161-10PC	P21	
	CY7B161-10VC	V21	
	CY7B161-10DMB	D22	Military
	CY7B161-10LMB	L54	
12	CY7B161-12DC	D22	Commercial
	CY7B161-12PC	P21	
	CY7B161-12VC	V21	
	CY7B161-12DMB	D22	Military
	CY7B161-12LMB	L54	
15	CY7B161-15DMB	D22	Military
	CY7B161-15LMB	L54	

Shaded area contains preliminary information.

Speed (ns)	Ordering Code	Package Type	Operating Range
8	CY7B162-8DC	D22	Commercial
	CY7B162-8PC	P21	
	CY7B162-8VC	V21	
10	CY7B162-10DC	D22	Commercial
	CY7B162-10PC	P21	
	CY7B162-10VC	V21	
	CY7B162-10DMB	D22	Military
	CY7B162-10LMB	L54	
12	CY7B162-12DC	D22	Commercial
	CY7B162-12PC	P21	
	CY7B162-12VC	V21	
	CY7B162-12DMB	D22	Military
	CY7B162-12LMB	L54	
15	CY7B162-15DMB	D22	Military
	CY7B162-15LMB	L54	

Shaded area contains preliminary information.

### MILITARY SPECIFICATIONS

#### Group A Subgroup Testing

#### DC Characteristics

Parameters	Subgroups
V <sub>OH</sub>	1, 2, 3
V <sub>OL</sub>	1, 2, 3
V <sub>IH</sub>	1, 2, 3
V <sub>IL Max.</sub>	1, 2, 3
I <sub>Ix</sub>	1, 2, 3
I <sub>OZ</sub>	1, 2, 3
I <sub>CC</sub>	1, 2, 3
I <sub>SB</sub>	1, 2, 3

#### Switching Characteristics

Parameters	Subgroups
<b>READ CYCLE</b>	
t <sub>AA</sub>	7, 8, 9, 10, 11
t <sub>OHA</sub>	7, 8, 9, 10, 11
t <sub>ACE</sub>	7, 8, 9, 10, 11
t <sub>DOE</sub>	7, 8, 9, 10, 11
<b>WRITE CYCLE</b>	
t <sub>SCE</sub>	7, 8, 9, 10, 11
t <sub>AW</sub>	7, 8, 9, 10, 11
t <sub>HA</sub>	7, 8, 9, 10, 11
t <sub>SA</sub>	7, 8, 9, 10, 11
t <sub>PWE</sub>	7, 8, 9, 10, 11
t <sub>SD</sub>	7, 8, 9, 10, 11
t <sub>HD</sub>	7, 8, 9, 10, 11
t <sub>AWE</sub> <sup>[15]</sup>	7, 8, 9, 10, 11
t <sub>ADV</sub> <sup>[15]</sup>	7, 8, 9, 10, 11

Note:

15. 7B161 only.