

J-FET INPUT QUAD OP-AMPS

- LOW POWER CONSUMPTION
- WIDE COMMON-MODE AND DIFFERENTIAL VOLTAGE RANGE
- LOW INPUT BIAS AND OFFSET CURRENT
- OUTPUT SHORT-CIRCUIT PROTECTION
- HIGH INPUT IMPEDANCE J-FET INPUT STAGE
- INTERNAL FREQUENCY COMPENSATION
- LATCH UP FREE OPERATION
- HIGH SLEW RATE : 13 V/ μ s (typ)

DESCRIPTION

These circuits are high speed J-FET input quad operational amplifiers incorporating well matched, high voltage J-FET and bipolar transistors in a monolithic integrated circuit.

The devices feature high slew rates, low input bias and offset currents, and low offset voltage temperature coefficient.

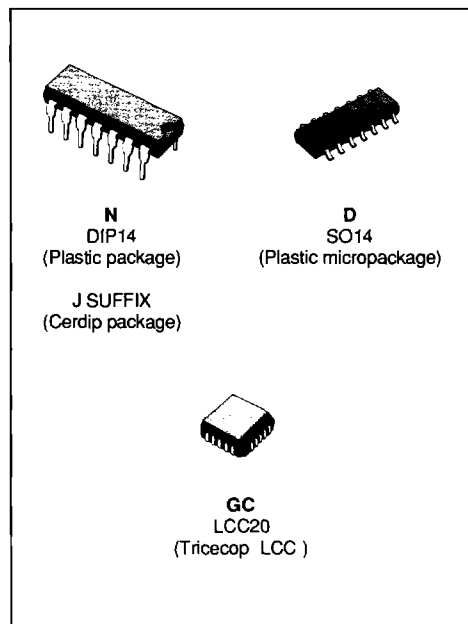

PIN CONNECTIONS (Top views)

**DIP14/CERDIP14
SO14**

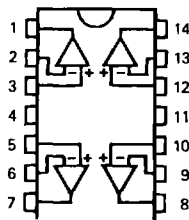

- | | |
|---------------------------|----------------------------|
| 1 - Output 1 | 8 - Output 3 |
| 2 - Inverting input 1 | 9 - Inverting input 3 |
| 3 - Non-inverting input 1 | 10 - Non-Inverting input 3 |
| 4 - V_{CC} | 11 - V_{CC} |
| 5 - Non-inverting input 2 | 12 - Non-Inverting input 4 |
| 6 - Inverting input 2 | 13 - Inverting input 4 |
| 7 - Output 2 | 14 - Output 4 |

LCC20

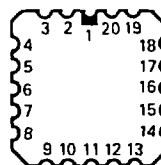

- | | |
|---------------------------|----------------------------|
| 1 - NC | 11 - NC |
| 2 - Output 1 | 12 - Output 3 |
| 3 - Inverting input 1 | 13 - Inverting input 3 |
| 4 - Non-inverting input 1 | 14 - Non-inverting input 3 |
| 5 - NC | 15 - NC |
| 6 - V_{CC} | 16 - V_{CC} |
| 7 - NC | 17 - NC |
| 8 - Non-inverting input 2 | 18 - Non-inverting input 4 |
| 9 - Inverting input 2 | 19 - Inverting input 4 |
| 10 - Output 2 | 20 - Output 4 |

ORDER CODES

Part Number	Temperature	Package
LF147GC	- 55 °C to + 125 °C	LCC
LF147AGC	- 55 °C to + 125 °C	LCC
LF147BGC	- 55 °C to + 125 °C	LCC
LF147J	- 55 °C to + 125 °C	CERDIP
LF147AJ	- 55 °C to + 125 °C	CERDIP
LF147BJ	- 55 °C to + 125 °C	CERDIP
LF247N	- 40 °C to + 105 °C	DIP14
LF247AN	- 40 °C to + 105 °C	DIP14
LF247BN	- 40 °C to + 105 °C	DIP14
LF247D	- 40 °C to + 105 °C	SO14
LF247AD	- 40 °C to + 105 °C	SO14
LF247BD	- 40 °C to + 105 °C	SO14
LF347N	0 °C to + 70 °C	DIP14
LF347AN	0 °C to + 70 °C	DIP14
LF347BN	0 °C to + 70 °C	DIP14
LF347D	0 °C to + 70 °C	SO14
LF347AD	0 °C to + 70 °C	SO14
LF347BD	0 °C to + 70 °C	SO14

ABSOLUTE MAXIMUM RATINGS

Symbol	Parameter	Value	Unit
V _{CC}	Supply Voltage (note 1)	± 18	V
V _i	Input Voltage (note 3)	± 15	V
V _{CC}	Diff. Input Voltage (note 2)	± 30	V
P _{tot}	Power Dissipation	680	mW
	Output Short-circuit Duration (note 4)	Infinite	
T _{oper}	Operating Free Air Temperature Range	LF347, A, B 0 to 70 LF247, A, B - 40 to 105 LF147, A, B - 55 to 125	°C
T _{stg}	Storage Temperature Range	- 65 to 150	°C

- Notes :**
1. All voltage values, except differential voltage, are with respect to the zero reference level (ground) of the supply voltages where the zero reference level is the midpoint between V_{CC} and V_{CC}.
 2. Differential voltages are at the non-inverting input terminal with respect to the inverting input terminal.
 3. The magnitude of the input voltage must never exceed the magnitude of the supply voltage or 15 volts, whichever is less.
 4. The output may be shorted to ground or to either supply. Temperature and /or supply voltages must be limited to ensure that the dissipation rating is not exceeded.

SCHEMATIC (each amplifier)

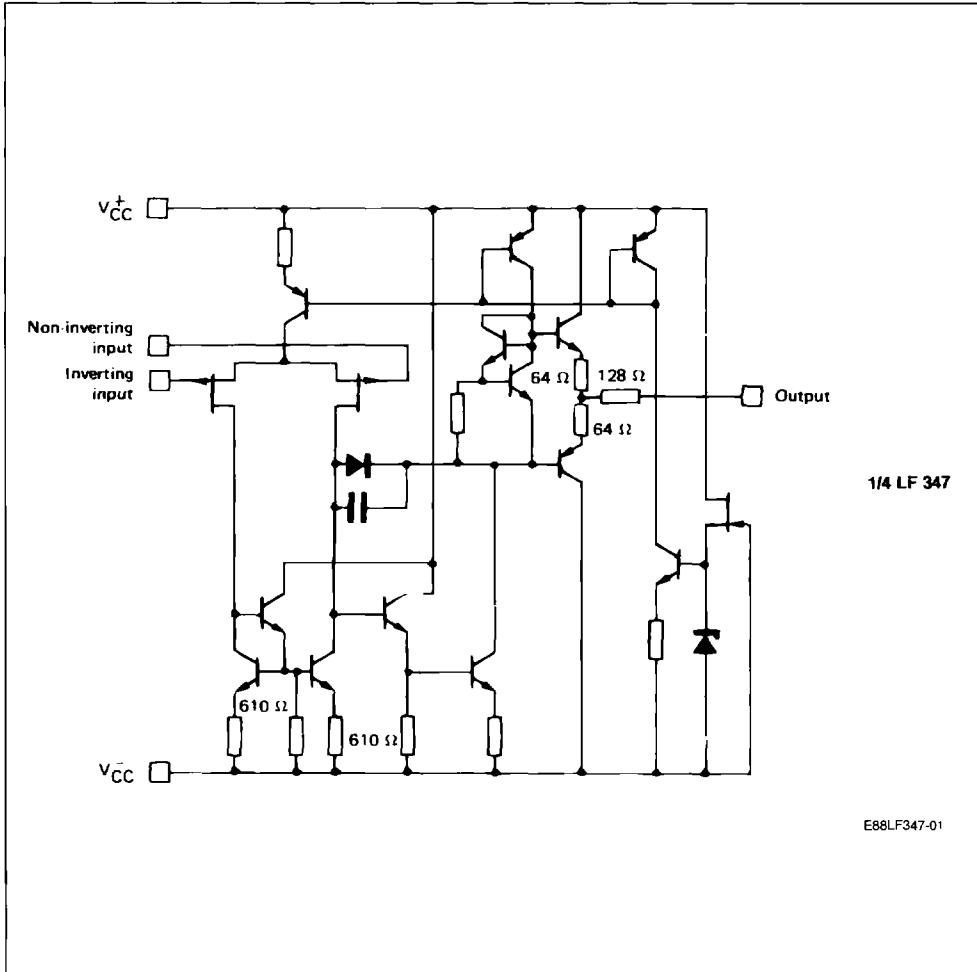

Case	Outputs	Inverting Inputs	Non-inverting Inputs	V _{cc}	V _{cc}	N.C.
DIP14 SO14 CERDIP14	1, 7, 14, 8	2, 6, 13, 9	3, 5, 12, 10	4	11	
LCC20	2, 10, 12, 20	3, 9, 13, 19	4, 8, 14, 18	6	16	*

* LCC20 : Other pins are not connected.

ELECTRICAL CHARACTERISTICS

$V_{CC} = \pm 15$ V (unless otherwise specified)

LF147, LF147B, LF147A $-55 \leq T_{amb} \leq +125$ °C

LF247, LF247B, LF247A $-40 \leq T_{amb} \leq +105$ °C

LF247, LF247B, LF247A $0 \leq T_{amb} \leq +70$ °C

Symbol	Parameter	LF147A, B LF247A, B LF347A, B			LF147 LF247 LF347			Unit
		Min.	Typ.	Max.	Min.	Typ.	Max.	
V_{io}	Input Offset Voltage $T_{amb} = 25$ °C ($R_S < 10$ k Ω) LF147B, LF247B, LF347B LF147A, LF247A, LF347A $T_{min} \leq T_{amb} \leq T_{max}$ LF147B, LF247B, LF347B LF147A, LF247A, LF347A		3 1	5 2		3	8 13	mV
DV_{io}	Input Offset Voltage Drift		10			10		μ V/°C
I_{io}	Input Offset Current * $T_{amb} = 25$ °C $T_{min} \leq T_{amb} \leq T_{max}$		5	50 4		5	50 4	ρ A nA
I_{ib}	Input Bias Current * $T_{amb} = 25$ °C $T_{min} \leq T_{amb} \leq T_{max}$		30	200 20		30	200 20	ρ A nA
A_{vd}	Large Signal Voltage Gain ($R_L > 2$ k Ω , $V_o = \pm 10$ V) $T_{amb} = 25$ °C $T_{min} \leq T_{amb} \leq T_{max}$	50 25	200		50 25	200		V/mV
SVR	Supply Voltage Rejection Ratio ($R_S < 10$ k Ω) $T_{amb} = 25$ °C $T_{min} \leq T_{amb} \leq T_{max}$	80 80	86		80 80	86		dB
I_{cc}	Supply Current, per Amp, no Load $T_{amb} = 25$ °C $T_{min} \leq T_{amb} \leq T_{max}$		1.4	2.5 2.5		1.4	2.5 2.5	mA
V_i	Input Voltage Range $T_{amb} = 25$ °C $T_{min} \leq T_{amb} \leq T_{max}$	-11		+11	-11		+11	V
CMR	Common Mode Rejection Ratio ($R_S < 10$ k Ω) $T_{amb} = 25$ °C $T_{min} \leq T_{amb} \leq T_{max}$	80 80	86		70 70	86		dB
I_{os}	Output Short-circuit Current $T_{amb} = 25$ °C $T_{min} \leq T_{amb} \leq T_{max}$	10 10	40	60 60	10 10	40	60 60	mA
$\pm V_{opp}$	Output Voltage Swing $T_{amb} = 25$ °C $T_{min} \leq T_{amb} \leq T_{max}$		$R_L \geq 2$ k Ω 11 $R_L \geq 10$ k Ω 12 13.5 $R_L \geq 2$ k Ω 11 $R_L \geq 10$ k Ω 12			11 12 13.5 11 12		V
S_{vo}	Slew-rate ($V_i = 10$ V, $R_L = 2$ k Ω) $C_L \leq 100$ pF, $T_{amb} = 25$ °C, unity gain		12	16		12	16	V/ μ s

* The input bias currents are junction leakage currents which approximately double for every 10 °C increase in the junction temperature.

ELECTRICAL CHARACTERISTICS (continued)

Symbol	Parameter	LF147A, B LF247A, B LF347A, B			LF147 LF247 LF347			Unit
		Min.	Typ.	Max.	Min.	Typ.	Max.	
t_r	Rise Time ($V_i = 20$ mV, $R_L = 2$ k Ω) $C_L = 100$ pF, $T_{amb} = 25$ °C, unity gain		0.1			0.1		μ s
K_{ov}	Overshoot ($V_i = 20$ mV, $R_L = 2$ k Ω) $C_L \leq 100$ pF, $T_{amb} = 25$ °C, unity gain)		10			10		%
GBP	Gain Bandwidth Product ($f = 100$ kHz, $T_{amb} = 25$ °C) $V_{in} = 10$ mV, $R_L = 2$ k Ω , $C_L = 100$ pF)	3.3	4.0	5.0	3.3	4.0	5.0	MHz
R_i	Input Resistance ($T_{amb} = 25$ °C)		10^{12}			10^{12}		Ω
THD	Total Harmonic Distortion ($f = 1$ kHz, $A_v = 20$ dB, $R_L = 2$ k Ω) $C_L \leq 100$ pF, $T_{amb} = 25$ °C, $V_o = 2$ V _{pp})		0.01			0.01		%
V_n	Equivalent Input Noise Voltage ($f = 1$ kHz, $R_g = 100$ Ω)		15			15		nV/ \sqrt{Hz}
ϕ_m	Phase Margin		45			45		Degrees
V_{o1}/V_{o2}	Channel Separation $A_{vd} = 100$, $T_{amb} = 25$ °C		120			120		dB

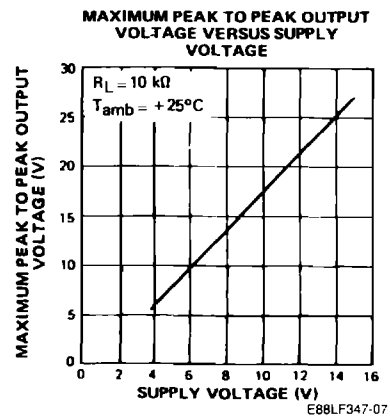
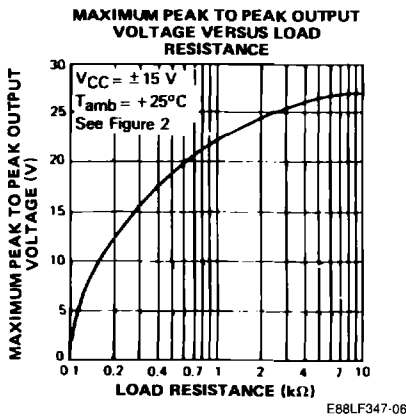
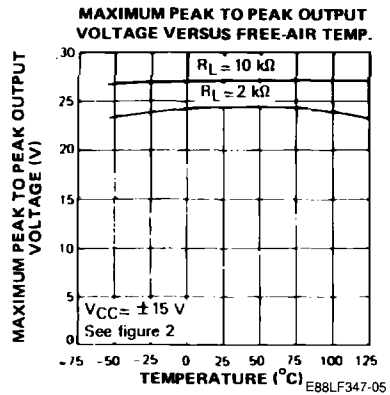
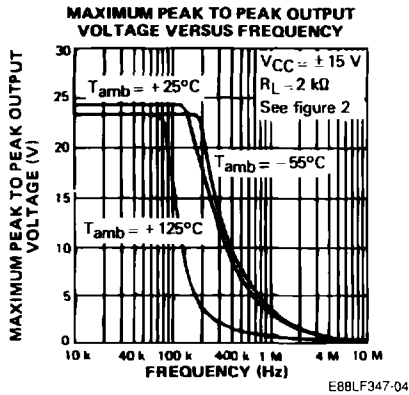
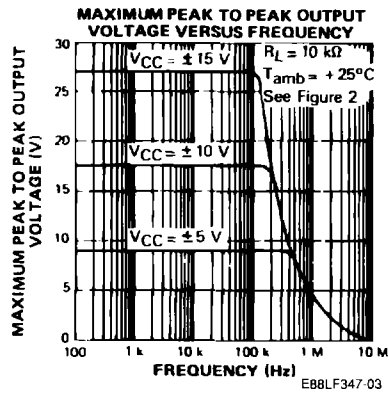
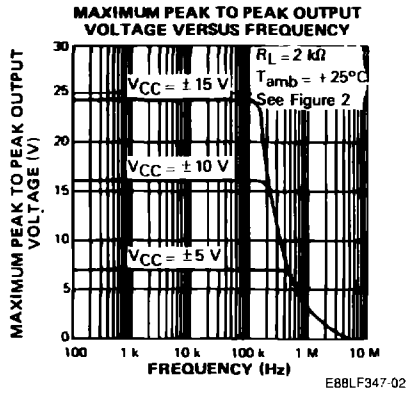

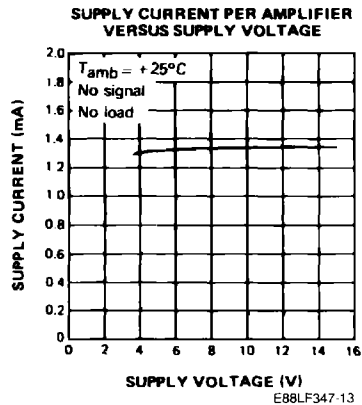
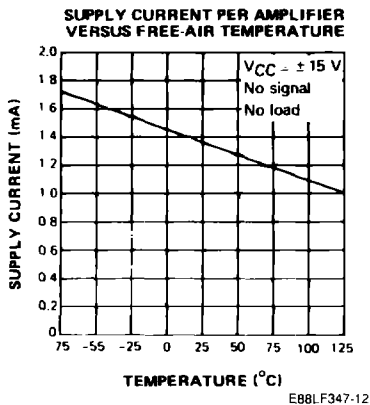
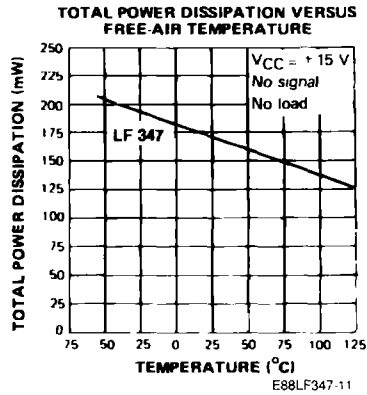
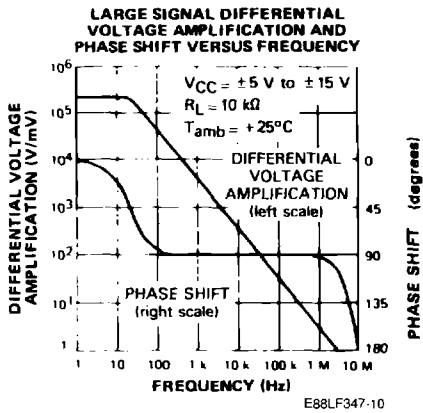
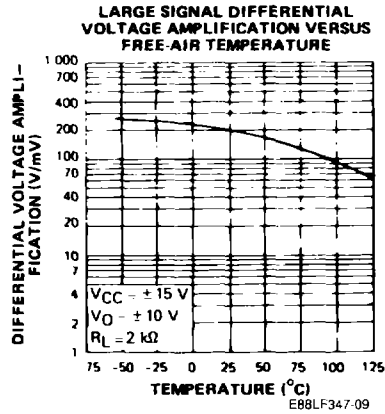
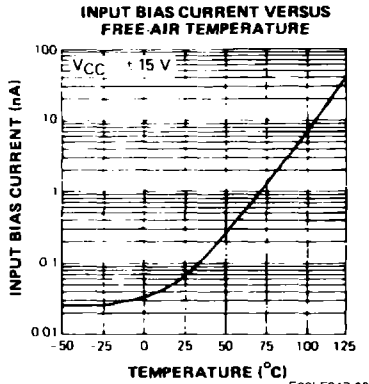

**COMMON MODE REJECTION RATIO
VERSUS FREE-AIR TEMPERATURE**

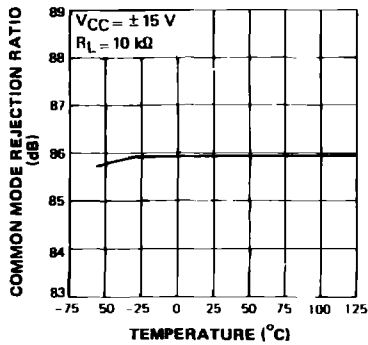

E88LF347-14

**VOLTAGE FOLLOWER LARGE
SIGNAL PULSE RESPONSE**

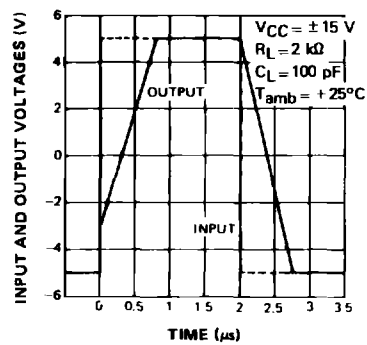

E88LF347-15

OUTPUT VOLTAGE VERSUS TIME

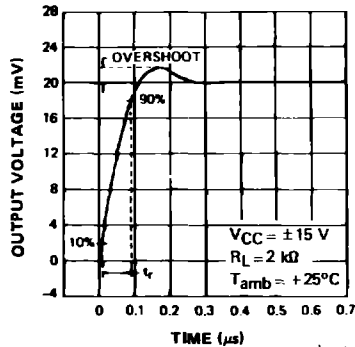

E88LF347-16

**EQUIVALENT INPUT NOISE VOL-
TAGE VERSUS FREQUENCY**

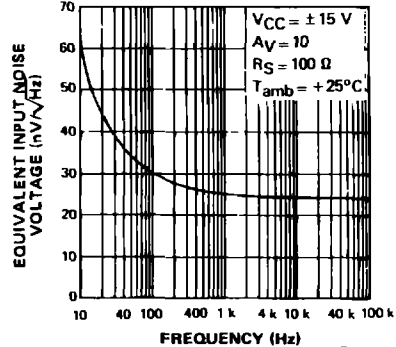

E88LF347-17

**TOTAL HARMONIC DISTORTION
VERSUS FREQUENCY**

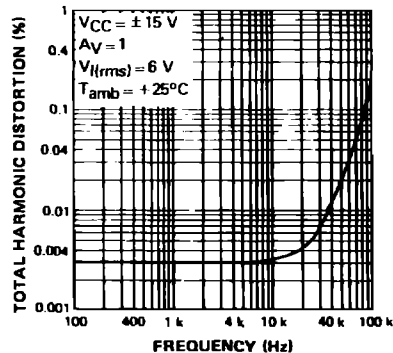

E88LF347-18

PARAMETER MEASUREMENT INFORMATION

Figure 1 : Voltage Follower.

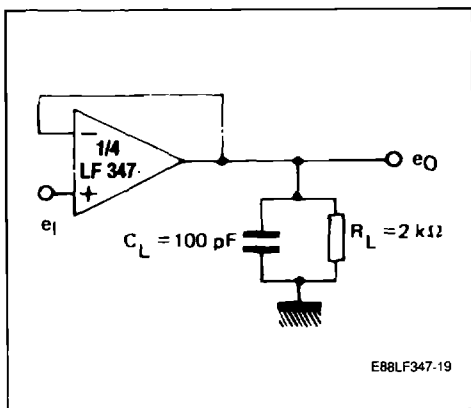
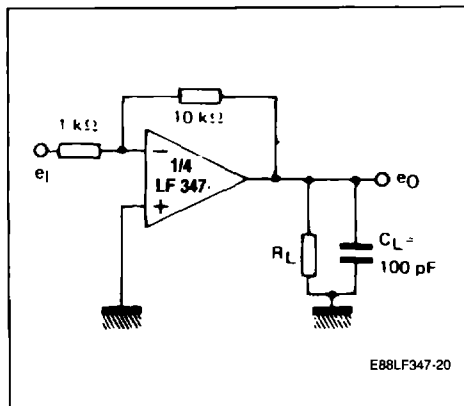
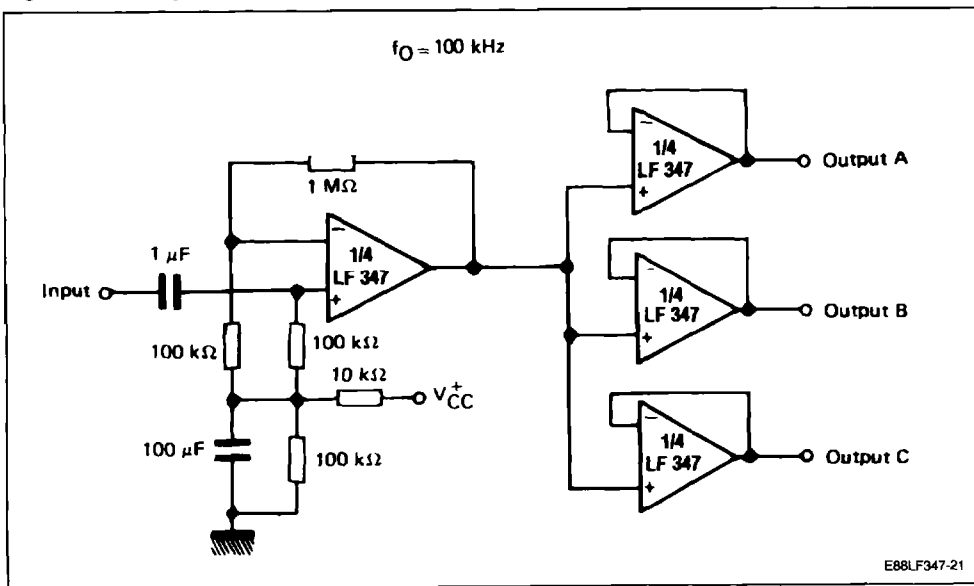

Figure 2 : Gain-of-10 Inverting Amplifier.



AUDIO DISTRIBUTION AMPLIFIER ($f_0 = 100$ KHz)

Figure 3 : Voltage Follower.



TYPICAL APPLICATION

POSITIVE FEEDBACK BANDPASS FILTER

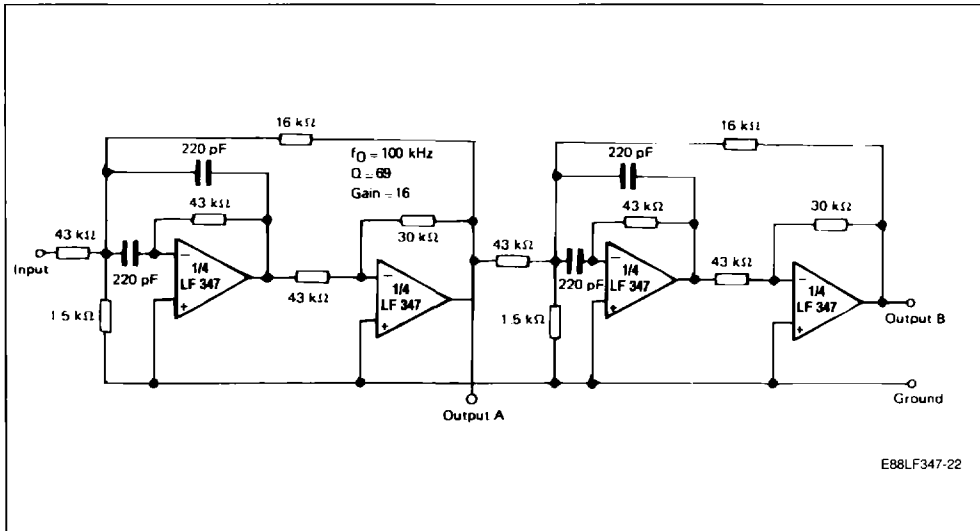

OUTPUT A

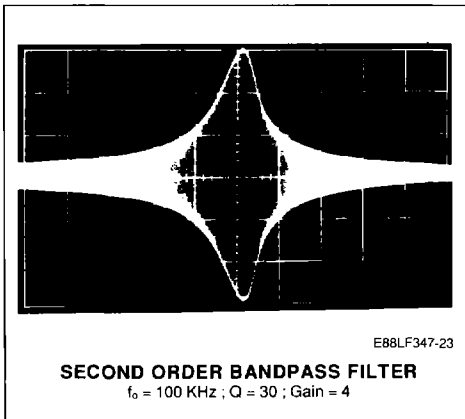

OUTPUT B

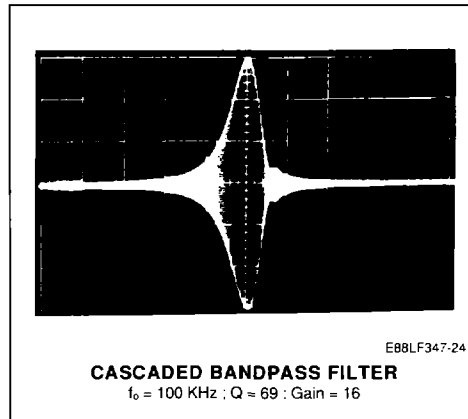

PACKAGE MECHANICAL DATA

14 PINS – PLASTIC DIP OR CerdIP

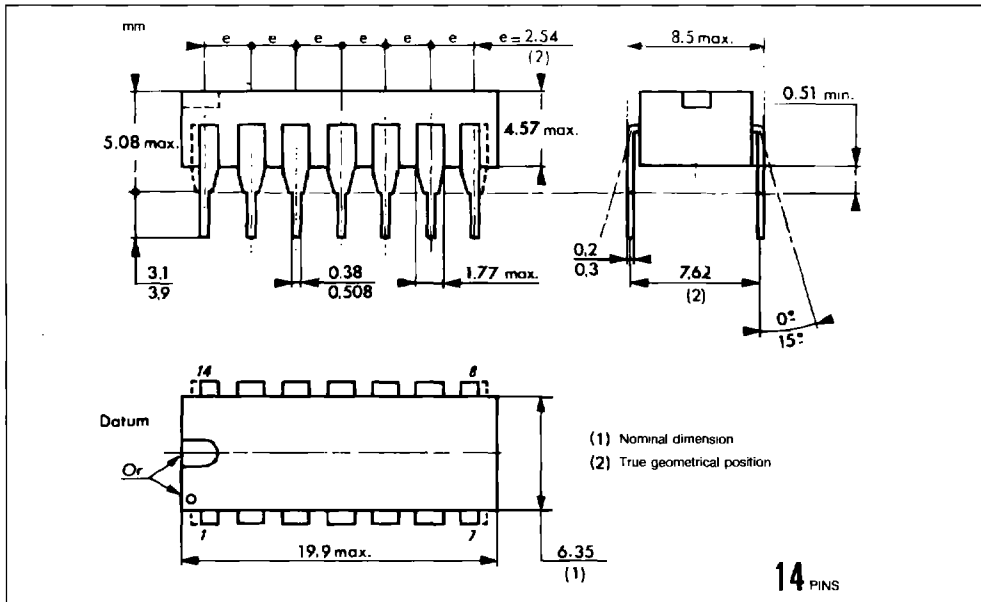

14 PINS – PLASTIC MICROPACKAGE SO

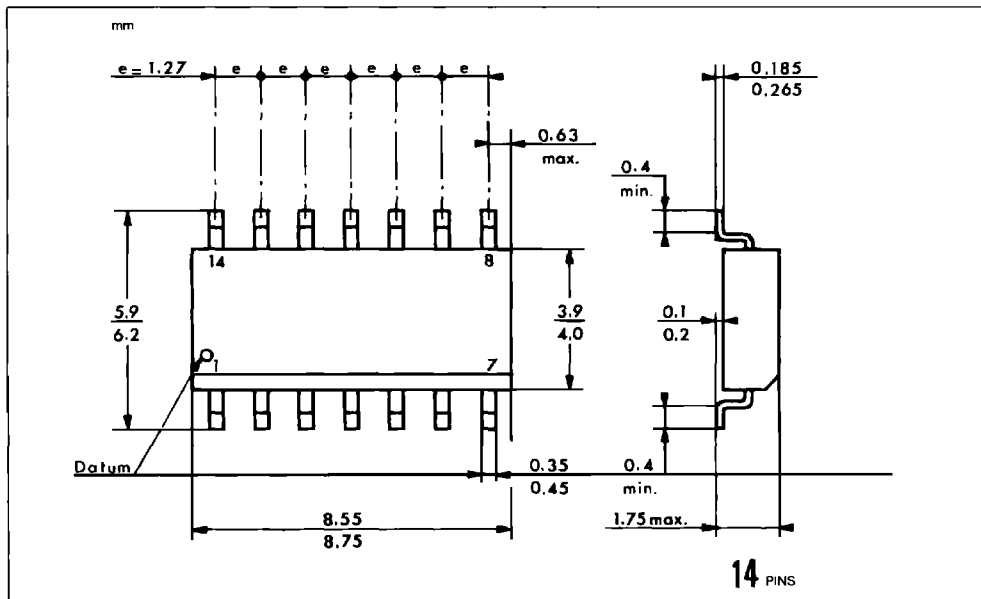

20 PINS – TRICECOP (LCC)

