

Triple 3-input AND gate

74LVC11

FEATURES

- Wide supply voltage range of 1.2 V to 3.6 V
- In accordance with JEDEC standard no. 8-1A.
- Inputs accept voltages up to 5.5 V
- CMOS low power consumption
- Direct interface with TTL levels
- Output capability: standard
- I_{CC} category: SSI

DESCRIPTION

The 74LVC11 is a high-performance, low power, low-voltage Si-gate CMOS device and superior to most advanced CMOS compatible TTL families.

The 74LVC11 provides the 3-input AND function.

QUICK REFERENCE DATA

GND = 0 V; $T_{amb} = 25^{\circ}\text{C}$; $t_r = t_f \leq 2.5$ ns

SYMBOL	PARAMETER	CONDITIONS	TYPICAL	UNIT
t_{PHL}/t_{PLH}	Propagation delay nA, nB, nC to nY	$C_L = 50$ pF; $V_{CC} = 3.3$ V	3.7	ns
C_I	Input capacitance		5.0	pF
C_{PD}	Power dissipation capacitance per gate	Notes 1 and 2	26	pF

NOTES:

1. C_{PD} is used to determine the dynamic power dissipation (P_D in μW)

$P_D = C_{PD} \times V_{CC}^2 \times f_i + \sum (C_L \times V_{CC}^2 \times f_o)$ where:

f_i = input frequency in MHz; C_L = output load capacity in pF;

f_o = output frequency in MHz; V_{CC} = supply voltage in V;

$\sum (C_L \times V_{CC}^2 \times f_o)$ = sum of the outputs.

2. The condition is $V_i = \text{GND to } V_{CC}$.

ORDERING INFORMATION

PACKAGES	TEMPERATURE RANGE	OUTSIDE NORTH AMERICA	NORTH AMERICA	DWG NUMBER
14-Pin Plastic SO	$-40^{\circ}\text{C to } +85^{\circ}\text{C}$	74LVC11 D	74LVC11 D	SOT108-1
14-Pin Plastic SSOP Type II	$-40^{\circ}\text{C to } +85^{\circ}\text{C}$	74LVC11 DB	74LVC11 DB	SOT337-1
14-Pin Plastic TSSOP Type I	$-40^{\circ}\text{C to } +85^{\circ}\text{C}$	74LVC11 PW	74LVC11PW DH	SOT402-1

PIN CONFIGURATION

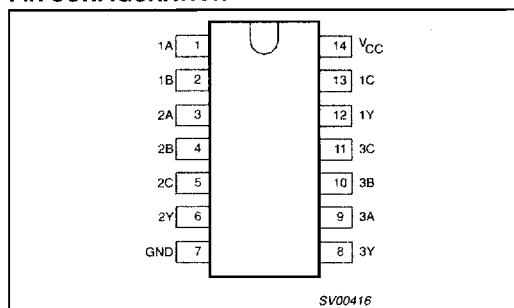

LOGIC SYMBOL (IEEE/IEC)

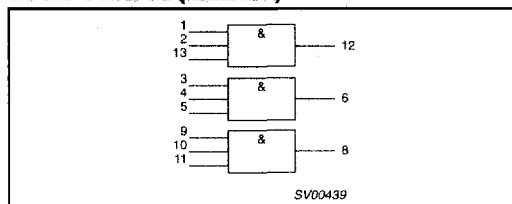

Triple 3-input AND gate

74LVC11

PIN DESCRIPTION

PIN NUMBER	SYMBOL	NAME AND FUNCTION
1, 3, 9	1A – 3A	Data inputs
2, 4, 10	1B – 3B	Data inputs
7	GND	Ground (0 V)
12, 6, 8	1Y – 3Y	Data outputs
13, 5, 11	1C – 3C	Data inputs
14	V _{CC}	Positive supply voltage

LOGIC SYMBOL

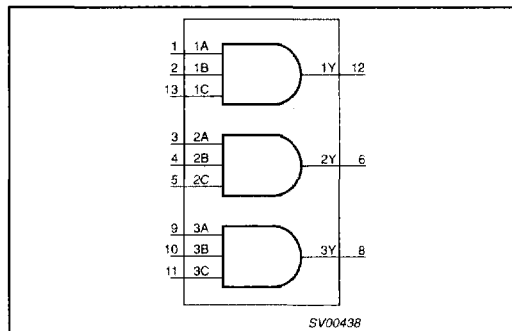

LOGIC DIAGRAM (ONE GATE)

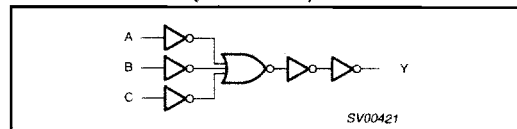

FUNCTION TABLE

INPUTS			OUTPUTS
nA	nB	nC	nY
L	L	L	L
L	L	H	L
L	H	L	L
L	H	H	L
H	L	L	L
H	L	H	L
H	H	L	L
H	H	H	H

NOTES:

H = HIGH voltage level
L = LOW voltage level

RECOMMENDED OPERATING CONDITIONS

SYMBOL	PARAMETER	CONDITIONS	LIMITS		UNIT
			MIN	MAX	
V _{CC}	DC supply voltage (for max. speed performance)		2.7	3.6	V
V _{CC}	DC supply voltage (for low-voltage applications)		1.2	3.6	V
V _I	DC input voltage range		0	5.5	V
V _O	DC output voltage range		0	V _{CC}	V
T _{amb}	Operating free-air temperature range		-40	+85	°C
t _r , t _f	Input rise and fall times	V _{CC} = 1.2 to 2.7V V _{CC} = 2.7 to 3.6V	0	20	ns/V
			0	10	

Triple 3-input AND gate

74LVC11

ABSOLUTE MAXIMUM RATINGS¹

In accordance with the Absolute Maximum Rating System (IEC 134)
 Voltages are referenced to GND (ground = 0V)

SYMBOL	PARAMETER	CONDITIONS	RATING	UNIT
V_{CC}	DC supply voltage		-0.5 to +6.5	V
I_{IK}	DC input diode current	$V_I < 0$	-50	mA
V_I	DC input voltage	Note 2	-0.5 to +5.5	V
I_{OK}	DC output diode current	$V_O > V_{CC}$ or $V_O < 0$	± 50	mA
V_O	DC output voltage	Note 2	-0.5 to $V_{CC} + 0.5$	V
I_O	DC output source or sink current	$V_O = 0$ to V_{CC}	± 50	mA
I_{GND}, I_{CC}	DC V_{CC} or GND current		± 100	mA
T_{stg}	Storage temperature range		-65 to +150	$^{\circ}C$
P_{TOT}	Power dissipation per package - plastic mini-pack (SO) - plastic shrink mini-pack (SSOP and TSSOP)	above +70 $^{\circ}C$ derate linearly with 8 mW/K above +60 $^{\circ}C$ derate linearly with 5.5 mW/K	500 500	mW

NOTES:

- Stresses beyond those listed may cause permanent damage to the device. These are stress ratings only and functional operation of the device at these or any other conditions beyond those indicated under "recommended operating conditions" is not implied. Exposure to absolute-maximum-rated conditions for extended periods may affect device reliability.
- The input and output voltage ratings may be exceeded if the input and output current ratings are observed.

DC ELECTRICAL CHARACTERISTICS

Over recommended operating conditions voltages are referenced to GND (ground = 0V)

SYMBOL	PARAMETER	TEST CONDITIONS	LIMITS			UNIT
			Temp = -40 $^{\circ}C$ to +85 $^{\circ}C$			
			MIN	TYP ¹	MAX	
V_{IH}	HIGH level Input voltage	$V_{CC} = 1.2V$	V_{CC}			V
		$V_{CC} = 2.7$ to $3.6V$	2.0			
V_{IL}	LOW level Input voltage	$V_{CC} = 1.2V$			GND	V
		$V_{CC} = 2.7$ to $3.6V$			0.8	
V_{OH}	HIGH level output voltage	$V_{CC} = 2.7V; V_I = V_{IH}$ or $V_{IL}; I_O = -12mA$	$V_{CC} - 0.5$			V
		$V_{CC} = 3.0V; V_I = V_{IH}$ or $V_{IL}; I_O = -100\mu A$	$V_{CC} - 0.2$	V_{CC}		
		$V_{CC} = 3.0V; V_I = V_{IH}$ or $V_{IL}; I_O = -12mA$	$V_{CC} - 0.6$			
		$V_{CC} = 3.0V; V_I = V_{IH}$ or $V_{IL}; I_O = -24mA$	$V_{CC} - 1.0$			
V_{OL}	LOW level output voltage	$V_{CC} = 2.7V; V_I = V_{IH}$ or $V_{IL}; I_O = 12mA$			0.40	V
		$V_{CC} = 3.0V; V_I = V_{IH}$ or $V_{IL}; I_O = 100\mu A$		GND	0.20	
		$V_{CC} = 3.0V; V_I = V_{IH}$ or $V_{IL}; I_O = 24mA$			0.55	
I_I	Input leakage current	$V_{CC} = 3.6V; V_I = 5.5V$ or GND		± 0.1	± 5	μA
I_{CC}	Quiescent supply current	$V_{CC} = 3.6V; V_I = V_{CC}$ or GND; $I_O = 0$		0.1	10	μA
ΔI_{CC}	Additional quiescent supply current per input pin	$V_{CC} = 2.7V$ to $3.6V; V_I = V_{CC} - 0.6V; I_O = 0$		5	500	μA

NOTE:

- All typical values are at $V_{CC} = 3.3V$ and $T_{amb} = 25^{\circ}C$.

