

## Isolated High Side FET Driver

### FEATURES

- Receives Both Power and Signal Across the Isolation Boundary
- 9 to 15 Volt High Level Gate Drive
- Under-voltage Lockout
- Programmable Over-current Shutdown and Restart
- Output Enable Function

### DESCRIPTION

The UC1725 and its companion chip, the UC1724, provide all the necessary features to drive an isolated MOSFET transistor from a TTL input signal. A unique modulation scheme is used to transmit both power and signals across an isolation boundary with a minimum of external components.

Protection circuitry, including under-voltage lockout, over-current shutdown, and gate voltage clamping provide fault protection for the MOSFET. High level gate drive is guaranteed to be greater than 9 volts and less than 15 volts under all conditions.

Uses include isolated off-line full bridge and half bridge drives for driving motors, switches, and any other load requiring full electrical isolation.

The UC1725 is characterized for operation over the full military temperature range of  $-55^{\circ}\text{C}$  to  $+125^{\circ}\text{C}$  while the UC2725 and UC3725 are characterized for  $-25^{\circ}\text{C}$  to  $+85^{\circ}\text{C}$  and  $0^{\circ}\text{C}$  to  $+70^{\circ}\text{C}$  respectively.

### BLOCK DIAGRAM

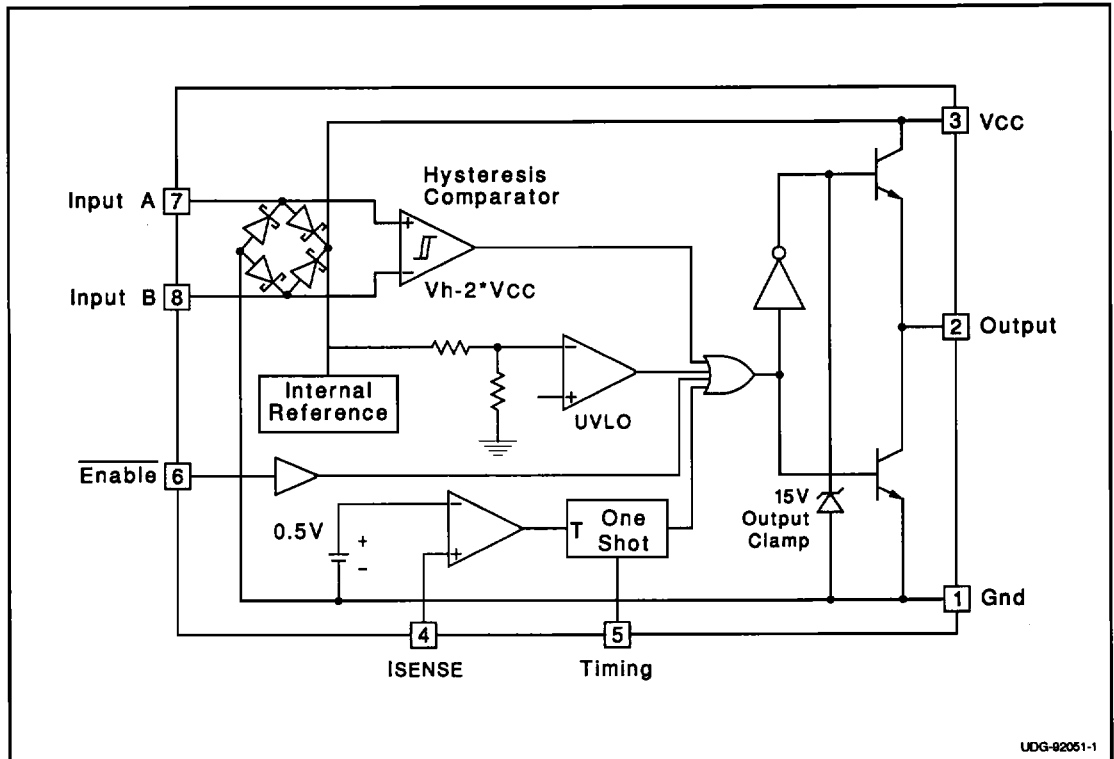

**ABSOLUTE MAXIMUM RATINGS**

Supply Voltage (pin 3) .....	30V
Power inputs (pins 7 & 8) .....	30V
Output current, source or sink (pin 2)	
DC .....	0.5A
Pulse (0.5 us) .....	2.0A
Enable and Current limit inputs (pins 4 & 6) .....	-0.3 to 6V
Power Dissipation at TA ≤ 25°C (DIL-8) .....	1W
Power Dissipation at TA ≤ 25°C (SO-14) .....	725mW
Lead Temperature (Soldering, 10 Seconds) .....	300°C

Note 1: Unless otherwise indicated, voltages are referenced to ground and currents are positive into, negative out of, the specified terminals (pin numbers refer to DIL-8 package).

Note 2: See Unitorde Integrated Circuits databook for information regarding thermal specifications and limitations of packages.

**CONNECTION DIAGRAMS**

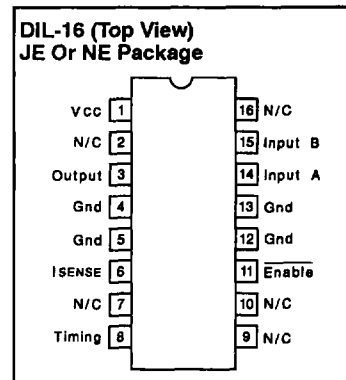
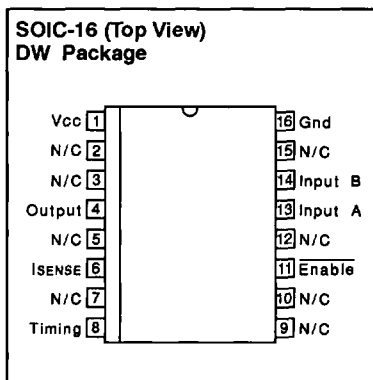
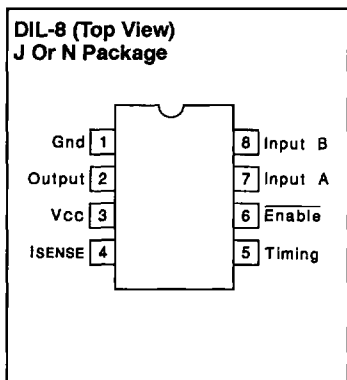
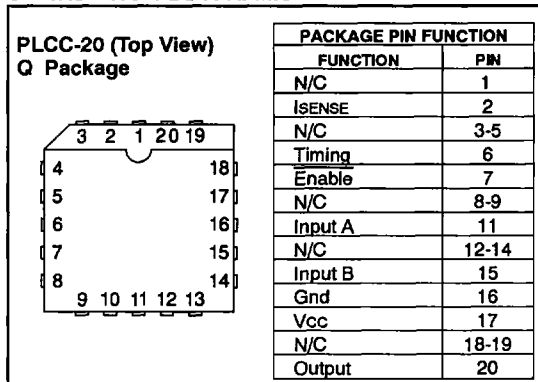

**ELECTRICAL CHARACTERISTICS:** (Unless otherwise stated, these specifications apply for -55°C ≤ TA ≤ 125°C for UC1725; -25°C ≤ TA ≤ 85°C for UC2725; 0°C ≤ TA ≤ 70°C for UC3725; Vcc (pin 3) = 0 to 15V, RT=10k, CT=2.2nf, TA = Tj, pin numbers refer to DIL-8 package.)

PARAMETER	TEST CONDITIONS	MIN	TYP	MAX	UNITS
<b>POWER INPUT SECTION (PINS 7 &amp; 8)</b>					
Forward Diode Drop, Schottky Rectifier	IF = 50ma		.55	.7	V
	IF = 500ma		1.1	1.5	V
<b>CURRENT LIMIT SECTION (PIN 4)</b>					
Input bias current	V <sub>PIN4</sub> = 0V		-1	-10	μA
Threshold voltage		0.4	0.5	0.6	V
Delay to outputs	V <sub>PIN4</sub> = 0 to 1V		100	250	ns
<b>TIMING SECTION (PIN 5)</b>					
Output Off Time		27	30	33	μs
Upper Mono Threshold		6.3	7.0	7.7	V
Lower Mono Threshold		1.9	2.0	2.3	V
<b>HYSTERESIS AMPLIFIER (PINS 7 &amp; 8)</b>					
Input Open Circuit Voltage	Inputs (pins 7 & 8), Open Circuited, TA = 25°C	7.0	Vcc/2	8.0	V
Input Impedance	TA = 25°C	23	28	33	kΩ
Hysteresis		26.5	2*Vcc	30.5	V
Delay to Outputs	V <sub>PIN7</sub> - V <sub>PIN8</sub> = Vcc + 1V		100	300	ns

**ELECTRICAL CHARACTERISTICS (cont.)**

(Unless otherwise stated, these specifications apply for  $-55^{\circ}\text{C} \leq \text{TA} \leq +125^{\circ}\text{C}$  for UC1725;  $-25^{\circ}\text{C} \leq \text{TA} \leq +85^{\circ}\text{C}$  for UC2725;  $0^{\circ}\text{C} \leq \text{TA} \leq +70^{\circ}\text{C}$  for UC3725;  $V_{\text{CC}}$  (pin 3) = 0 to 15V,  $R_{\text{T}}=10\text{k}$ ,  $C_{\text{T}}=2.2\text{nf}$ ,  $\text{TA} = \text{TJ}$ , pin numbers refer to DIL-8 package.)

PARAMETER	TEST CONDITIONS	MIN	TYP	MAX	UNITS
<b>ENABLE SECTION (PIN 6)</b>					
High Level Input Voltage		2.1	1.4		V
Low Level Input Voltage			1.4	.8	V
Input Bias Current			-250	-500	$\mu\text{A}$
<b>OUTPUT SECTION</b>					
Output Low Level	$I_{\text{OUT}} = 20\text{mA}$		0.35	0.5	V
	$I_{\text{OUT}} = 200\text{mA}$		0.6	2.5	V
Output High Level	$I_{\text{OUT}} = -20\text{mA}$	13	13.5		V
	$I_{\text{OUT}} = -200\text{mA}$	12	13.4		V
	$V_{\text{CC}} = 30\text{V}$ , $I_{\text{OUT}} = -20\text{mA}$		14	15	V
Rise/Fall Time	$C_{\text{T}} = 1\text{nf}$		30	60	ns
<b>UNDER VOLTAGE LOCKOUT</b>					
UVLO Low Saturation	20mA, $V_{\text{CC}} = 8\text{V}$		0.8	1.5	V
Start-up Threshold		11.2	12	12.6	V
Threshold Hysteresis		.75	1.0	1.12	V
<b>TOTAL STANDBY CURRENT</b>					
Supply Current			12	16	ma

**APPLICATION AND OPERATION INFORMATION**

**INPUTS:** Figure 1 shows the rectification and detection scheme used in the UC1725 to derive both power and signal information from the input waveform.  $V_{\text{CC}}$  is generated by peak detecting the input signal via the internal bridge rectifier and storing on a small external capacitor,  $C_1$ . Note that this capacitor is also used to bypass high pulse currents in the output stage, and therefore should be placed directly between pins 1 and 3 using minimal lead lengths.

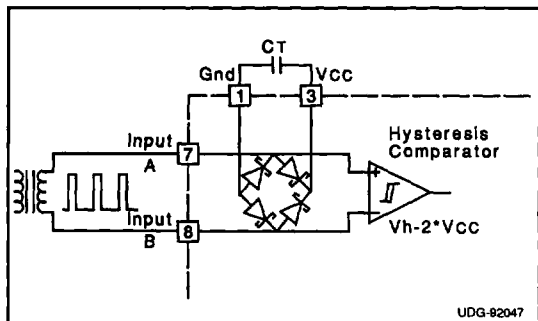

FIGURE 1 - Input Stage

Signal detection is performed by the internal hysteresis comparator which senses the polarity of the input signal as shown in Figure 2. This is accomplished by setting (resetting) the comparator only if the input signal exceeds  $V_{\text{CC}}$  ( $-V_{\text{CC}}$ ). In some cases it may be necessary to

add a damping resistor across the transformer secondary to minimize ringing and eliminate false triggering of the hysteresis amplifier as shown in Figure 3.

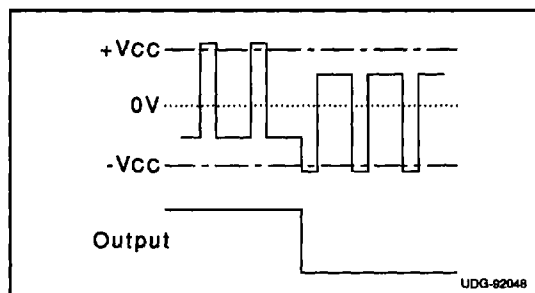

FIGURE 2 - Input Waveform (DIL-8 Pin 7 - Pin 8)

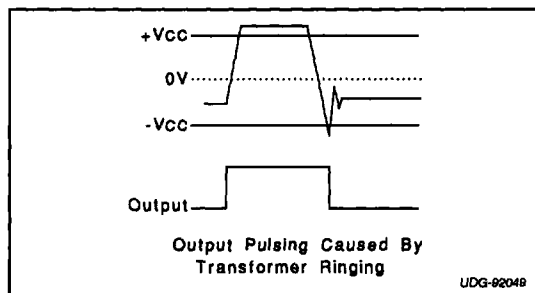

FIGURE 3 - Signal Detection

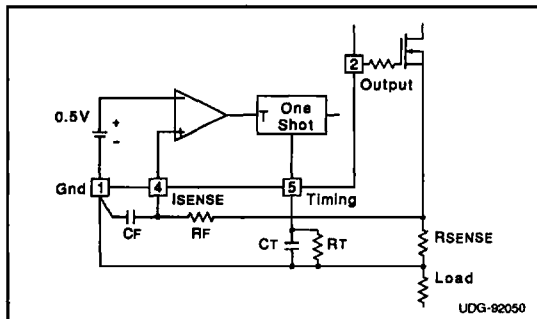

FIGURE 4 - Current Limit

**CURRENT LIMIT AND TIMING:** Current sensing and shutdown can be implemented directly at the output using the scheme shown in Figure 4. Alternatively, a current transformer can be used in place of RSENSE. A small RC filter in series with the input (pin 4) is generally needed to eliminate the leading edge current spike caused by parasitic circuit capacitances being charged during turn on. Due to the speed of the current sense circuit, it is very important to ground CF directly to Gnd as shown to eliminate false triggering of the one shot caused by ground drops.

One shot timing is easily programmed using an external

capacitor and resistor as shown in Figure 4. This, in turn, controls the output off time according to the formula:

$$T_{OFF} = 1.28 \cdot RC.$$

If current limit feature is not required, simply ground pin 4 and leave pin 5 open.

**OUTPUT:** Gate drive to the power FET is provided by a totem pole output stage capable of sourcing and sinking currents in excess of 1 amp. The undervoltage lockout circuit guarantees that the high level output will never be less than 9 volts. In addition, during undervoltage lockout, the output stage will actively sink current to eliminate the need for an external gate to source resistor. High level output is also clamped to 15 volts. Under high capacitive loading however, the output may overshoot 2 to 3 volts, due to the drivers' inability to switch from full to zero output current instantaneously. In a practical circuit this is not normally a concern. A few ohms of series gate resistance is normally required to prevent parasitic oscillations, and will also eliminate overshoot at the gate.

**ENABLE:** An enable pin is provided as a fast, digital input that can be used in a number of applications to directly switch the output. Figure 6 shows a simple means of providing a fast, high voltage translation by using a small signal, high voltage transistor in a cascode configuration. Note that the UC1725 is still used to provide power, drive and protection circuitry for the power FET.

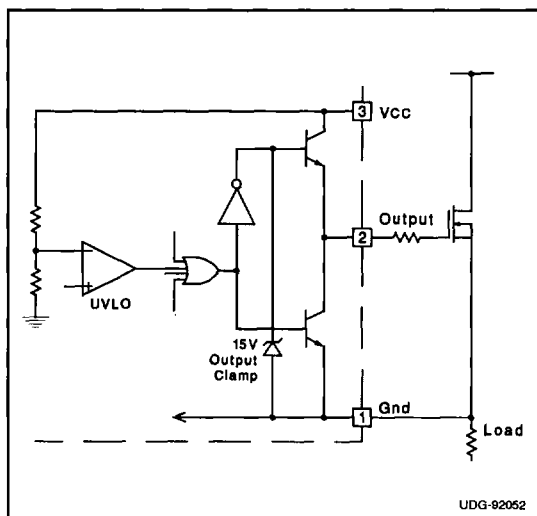

FIGURE 5 - Output Circuit

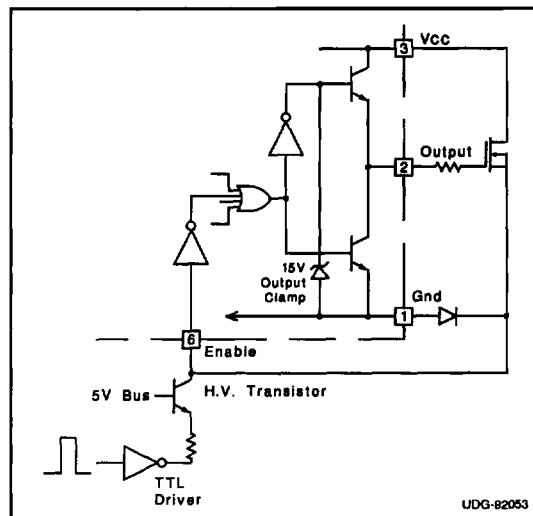

FIGURE 6 - Using Enable Pin as a High Speed Input Path