

7416, 17 Inverter/Buffer/Drivers

'16 Hex Inverter Buffer/Driver (Open Collector)

'17 Hex Buffer/Driver (Open Collector)

Product Specification

Logic Products

TYPE	TYPICAL PROPAGATION DELAY	TYPICAL SUPPLY CURRENT (TOTAL)
7416	10ns (t _{PLH}) 15ns (t _{PHL})	31mA
7417	6ns (t _{PLH}) 20ns (t _{PHL})	25mA

ORDERING CODE

PACKAGES	COMMERCIAL RANGE V _{CC} = 5V ±5%; T _A = 0°C to +70°C
Plastic DIP	N7416N, N7417N
Plastic SO	N7417D

FUNCTION TABLE

'16		'17	
INPUT	OUTPUT	INPUT	OUTPUT
A	Y	A	Y
L	H	L	L
H	L	H	H

H = HIGH voltage level
L = LOW voltage level

NOTE:

For information regarding devices processed to Military Specifications, see the Signetics Military Products Data Manual.

INPUT AND OUTPUT LOADING AND FAN-OUT TABLE

PINS	DESCRIPTION	74
A	Input	1uI
Y	Output	10uI

NOTE:

A 74 unit load (uI) is understood to be 40μA I_{IH} and -1.6mA I_{IL}.

PIN CONFIGURATION

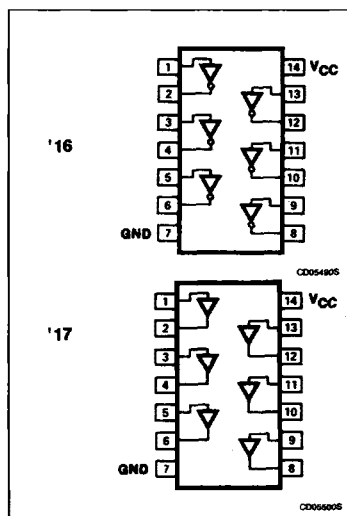

LOGIC SYMBOL

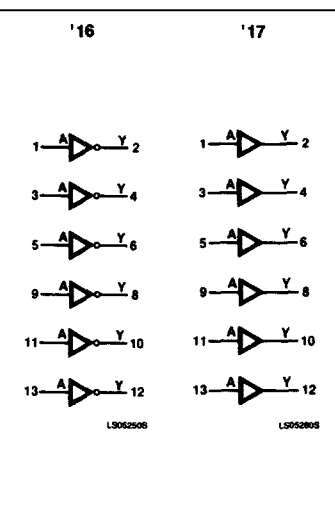

LOGIC SYMBOL (IEEE/IEC)

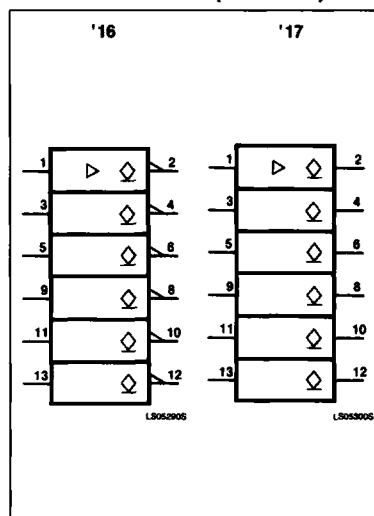

Inverter/Buffer/Drivers

7416, 17

ABSOLUTE MAXIMUM RATINGS (Over operating free-air temperature range unless otherwise noted.)

PARAMETER		74	UNIT
V _{CC}	Supply voltage	7.0	V
V _{IN}	Input voltage	-0.5 to +5.5	V
I _{IN}	Input current	-30 to +5	mA
V _{OUT}	Voltage applied to output in HIGH output state	-0.5 to +15	V
T _A	Operating free-air temperature range	0 to 70	°C

RECOMMENDED OPERATING CONDITIONS

PARAMETER	74			UNIT	
	Min	Nom	Max		
V _{CC}	Supply voltage	4.75	5.0	5.25	V
V _{IH}	HIGH-level input voltage	2.0			V
V _{IL}	LOW-level input voltage			+0.8	V
I _{IK}	Input clamp current			-12	mA
V _{OH}	HIGH-level output voltage			15	V
I _{OL}	LOW-level output current			40	mA
T _A	Operating free-air temperature	0		70	°C

5

TEST CIRCUITS AND WAVEFORMS

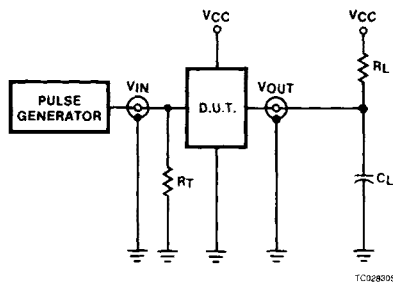

Test Circuit For 74 Open Collector Outputs

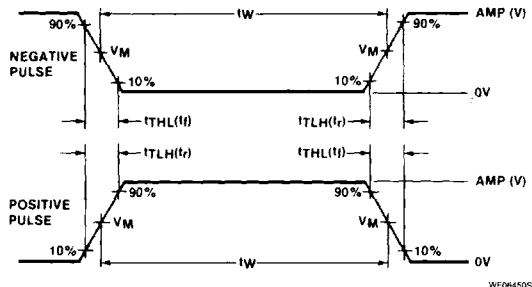

V_M = 1.3V for 74LS; V_M = 1.5V for all other TTL families.

Input Pulse Definition

DEFINITIONS

R_L = Load resistor to V_{CC}; see AC CHARACTERISTICS for value.

C_L = Load capacitance includes jig and probe capacitance; see AC CHARACTERISTICS for value.

R_T = Termination resistance should be equal to Z_{OUT} of Pulse Generators.

D = Diodes are 1N916, 1N3064, or equivalent.

t_{PLH}, t_{PLL} Values should be less than or equal to the table entries.

FAMILY	INPUT PULSE REQUIREMENTS				
	Amplitude	Rep. Rate	Pulse Width	t _{PLH}	t _{PLL}
74	3.0V	1MHz	500ns	7ns	7ns
74LS	3.0V	1MHz	500ns	15ns	6ns
74S	3.0V	1MHz	500ns	2.5ns	2.5ns

Inverter/Buffer/Drivers

7416, 17

DC ELECTRICAL CHARACTERISTICS (Over recommended operating free-air temperature range unless otherwise noted.)

PARAMETER	TEST CONDITIONS ¹	7416, 7417			UNIT	
		Min	Typ ²	Max		
I _{OH} HIGH-level output current	V _{CC} = MIN, V _{IH} = MIN, V _{IL} = MAX, V _{OH} = 15V			250	μA	
V _{OL} LOW-level output voltage	V _{CC} = MIN, V _{IH} = MIN, V _{IL} = MAX	I _{OL} = 16mA		0.4	V	
		I _{OL} = 30mA				
		I _{OL} = 40mA		0.7	V	
V _{IK} Input clamp voltage	V _{CC} = MIN, I _I = I _{IK}			-1.5	V	
I _I Input current at maximum input voltage	V _{CC} = MAX, V _I = 5.5V			1.0	mA	
I _{IH} HIGH-level input current	V _{CC} = MAX, V _I = 2.4V			40	μA	
I _{IL} LOW-level input current	V _{CC} = MAX, V _I = 0.4V			-1.6	mA	
I _{CC} Supply current (total)	V _{CC} = MAX	I _{CCH} Outputs HIGH	'16	30	48	mA
		I _{CCL} Outputs LOW		32	51	mA
		I _{CCH} Outputs HIGH	'17	29	41	mA
		I _{CCL} Outputs LOW		21	30	mA

NOTES:

- For conditions shown as MIN or MAX, use the appropriate value specified under recommended operating conditions for the applicable type.
- All typical values are at V_{CC} = 5V, T_A = 25°C.

AC WAVEFORMS

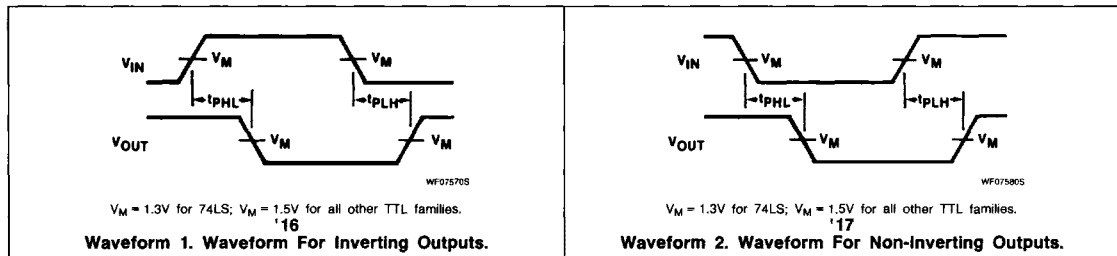

AC ELECTRICAL CHARACTERISTICS T_A = 25°C, V_{CC} = 5.0V

PARAMETER	TEST CONDITIONS	7416		7417		UNIT
		C _L = 15pF, R _L = 110Ω		C _L = 15pF, R _L = 110Ω		
		Min	Max	Min	Max	
t _{PLH} t _{PHL} Propagation delay	Waveform 1, '16 Waveform 2, '17		15 23		10 30	ns