

National Semiconductor is now part of
Texas Instruments.

Search <http://www.ti.com/> for the latest technical
information and details on our current products and services.

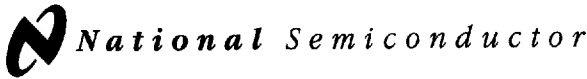

LM136-5.0/LM236-5.0/LM336-5.0, 5.0V Reference Diode

General Description

The LM136-5.0/LM236-5.0/LM336-5.0 integrated circuits are precision 5.0V shunt regulator diodes. These monolithic IC voltage references operate as a low temperature coefficient 5.0V zener with 0.6Ω dynamic impedance. A third terminal on the LM136-5.0 allows the reference voltage and temperature coefficient to be trimmed easily.

The LM136-5.0 series is useful as a precision 5.0V low voltage reference for digital voltmeters, power supplies or op amp circuitry. The 5.0V makes it convenient to obtain a stable reference from low voltage supplies. Further, since the LM136-5.0 operates as a shunt regulator, it can be used as either a positive or negative voltage reference.

The LM136-5.0 is rated for operation over -55°C to +125°C while the LM236-5.0 is rated over a -25°C to +85°C temperature range. The LM336-5.0 is rated for oper-

ation over a 0°C to +70°C temperature range. See the connection diagrams for available packages. For applications requiring 2.5V see LM136-2.5.

Features

- Adjustable 4V to 6V
- Low temperature coefficient
- Wide operating current of 600 μA to 10 mA
- 0.6Ω dynamic impedance
- ± 1% initial tolerance available
- Guaranteed temperature stability
- Easily trimmed for minimum temperature drift
- Fast turn-on
- Three lead transistor package

Connection Diagrams

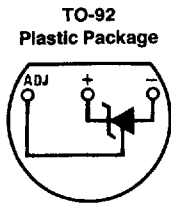

TL/H/5716-4

Bottom View

Order Number LM236AZ-5.0,
LM336Z-5.0 or LM336BZ-5.0
See NS Package Number Z03A

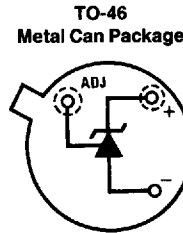

TL/H/5716-5

Bottom View

Order Number LM136H-5.0,
LM136H-5.0/883, LM236H-5.0,
LM136AH-5.0, LM136AH-5.0/883,
or LM236AH-5.0
See NS Package Number H03H

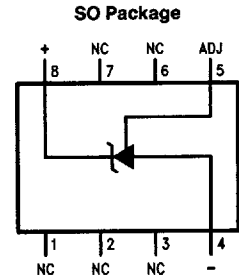

TL/H/5716-7

Order Number LM336M-5.0 or
LM336BM-5.0
See NS Package Number M08A

Typical Applications

5.0V Reference

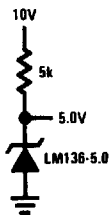

TL/H/5716-1

5.0V Reference with Minimum Temperature Coefficient

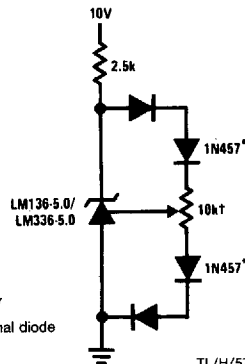

TL/H/5716-15

*Adjust to 5.00V

*Any silicon signal diode

Trimmed 4V to 6V Reference with Temperature Coefficient Independent of Breakdown Voltage

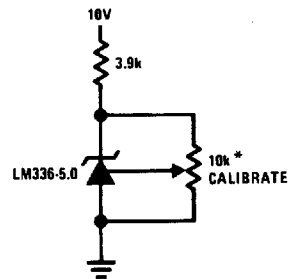

TL/H/5716-3

*Does not affect temperature coefficient

Absolute Maximum Ratings (Note 1)

If Military/Aerospace specified devices are required, please contact the National Semiconductor Sales Office/Distributors for availability and specifications.

Reverse Current	15mA
Forward Current	10mA
Storage Temperature	-60°C to +150°C
Operating Temperature Range (Note 2)	
LM136-5.0	-55°C to +150°C
LM236-5.0	-25°C to +85°C
LM336-5.0	0°C to +70°C

Soldering Information

TO-92 Package (10 sec.)	260°C
TO-46 Package (10 sec.)	300°C
SO Package	
Vapor Phase (60 sec.)	215°C
Infrared (15 sec.)	220°C

See AN-450 "Surface Mounting Methods and Their Effect on Product Reliability" (appendix D) for other methods of soldering surface mount devices.

Electrical Characteristics (Note 3)

Parameter	Conditions	LM136A-5.0/LM236A-5.0 LM136-5.0/LM236-5.0			LM336B-5.0 LM336-5.0			Units
		Min	Typ	Max	Min	Typ	Max	
Reverse Breakdown Voltage	$T_A = 25^\circ\text{C}$, $I_R = 1\text{ mA}$							
	LM136-5.0/LM236-5.0/LM336-5.0 LM136A-5.0/LM236A-5.0, LM336B-5.0	4.9 4.95	5.00 5.00	5.1 5.05	4.8 4.90	5.00 5.00	5.2 5.1	V V
Reverse Breakdown Change With Current	$T_A = 25^\circ\text{C}$, $600\ \mu\text{A} \leq I_R \leq 10\text{ mA}$		6	12		6	20	mV
Reverse Dynamic Impedance	$T_A = 25^\circ\text{C}$, $I_R = 1\text{ mA}$, $f = 100\text{ Hz}$		0.6	1.2		0.6	2	Ω
Temperature Stability (Note 4)	V_R Adjusted 5.00V $I_R = 1\text{ mA}$, (Figure 2) $0^\circ\text{C} \leq T_A \leq 70^\circ\text{C}$ (LM336-5.0) $-25^\circ\text{C} \leq T_A \leq +85^\circ\text{C}$ (LM236-5.0) $-55^\circ\text{C} \leq T_A \leq +125^\circ\text{C}$ (LM136-5.0)					4	12	mV
			7	18				mV
			20	36				mV
Reverse Breakdown Change With Current	$600\ \mu\text{A} \leq I_R \leq 10\text{ mA}$		6	17		6	24	mV
Adjustment Range	Circuit of Figure 1		± 1			± 1		V
Reverse Dynamic Impedance	$I_R = 1\text{ mA}$		0.8	1.6		0.8	2.5	Ω
Long Term Stability	$T_A = 25^\circ\text{C} \pm 0.1^\circ\text{C}$, $I_R = 1\text{ mA}$, $t = 1000\text{ hrs}$		20			20		ppm

Note 1: Absolute Maximum Ratings indicate limits beyond which damage to the device may occur. Electrical specifications do not apply when operating the device beyond its specified operating conditions.

Note 2: For elevated temperature operation, T_J max is:

LM136	150°C
LM236	125°C
LM336	100°C

Thermal Resistance	TO-92	TO-46	SO-8
θ_{JA} (Junction to Ambient)	180°C/W (0.4" Leads) 170°C/W (0.125" Leads)	440°C/W	165°C/W
θ_{JC} (Junction to Case)	N/A	80°C/W	N/A

Note 3: Unless otherwise specified, the LM136-5.0 is specified from $-55^\circ\text{C} \leq T_A \leq +125^\circ\text{C}$, the LM236-5.0 from $-25^\circ\text{C} \leq T_A \leq +85^\circ\text{C}$ and the LM336-5.0 from $0^\circ\text{C} \leq T_A \leq +70^\circ\text{C}$.

Note 4: Temperature stability for the LM336 and LM236 family is guaranteed by design. Design limits are guaranteed (but not 100% percent production tested) over the indicated temperature and supply voltage ranges. These limits are not used to calculate outgoing quality levels. Stability is defined as the maximum change in V_{REF} from 25°C to $T_A(\text{min})$ or $T_A(\text{max})$.

Typical Performance Characteristics

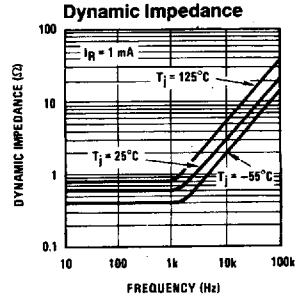
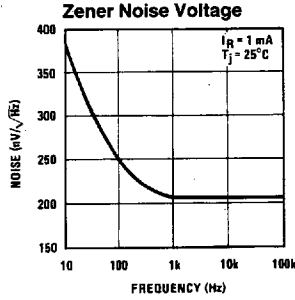
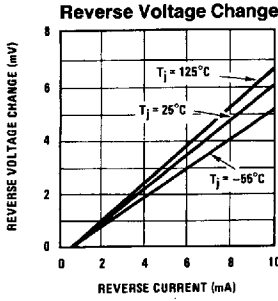

TL/H/5716-2

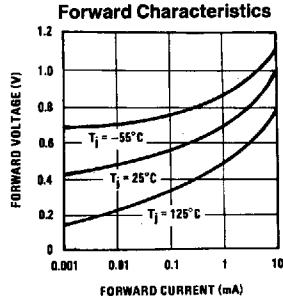
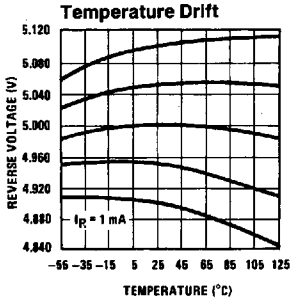
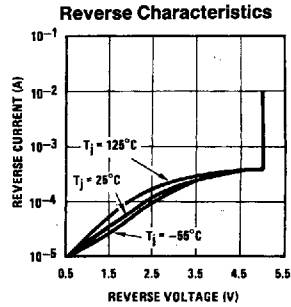
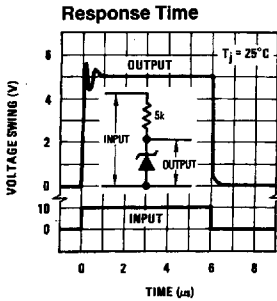

TL/H/5716-8

Application Hints

The LM136-5.0 series voltage references are much easier to use than ordinary zener diodes. Their low impedance and wide operating current range simplify biasing in almost any circuit. Further, either the breakdown voltage or the temperature coefficient can be adjusted to optimize circuit performance.

Figure 1 shows an LM136-5.0 with a 10k potentiometer for adjusting the reverse breakdown voltage. With the addition of R1 the breakdown voltage can be adjusted without affecting the temperature coefficient of the device. The adjustment range is usually sufficient to adjust for both the initial device tolerance and inaccuracies in buffer circuitry.

If minimum temperature coefficient is desired, four diodes can be added in series with the adjustment potentiometer as shown in Figure 2. When the device is adjusted to 5.00V the temperature coefficient is minimized. Almost any silicon signal diode can be used for this purpose such as a 1N914, 1N4148 or a 1N457. For proper temperature compensation the diodes should be in the same thermal environment as the LM136-5.0. It is usually sufficient to mount the diodes near the LM136-5.0 on the printed circuit board. The absolute resistance of the network is not critical and any value from 2k to 20k will work. Because of the wide adjustment range, fixed resistors should be connected in series with the pot to make pot setting less critical.

Application Hints (Continued)

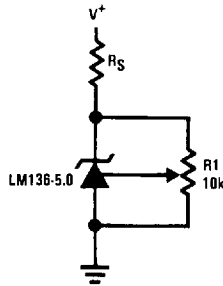

TL/H/5716-9

FIGURE 1. LM136-5.0 with Pot for Adjustment of Breakdown Voltage (Trim Range = ± 1.0V Typical)

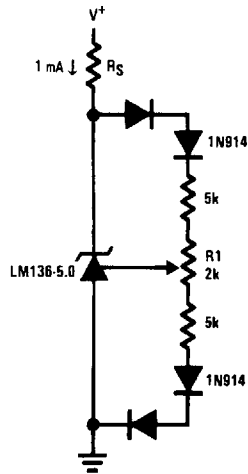

TL/H/5716-10

FIGURE 2. Temperature Coefficient Adjustment (Trim Range = ± 0.5V Typical)

Typical Applications (Continued)

Precision Power Regulator with Low Temperature Coefficient

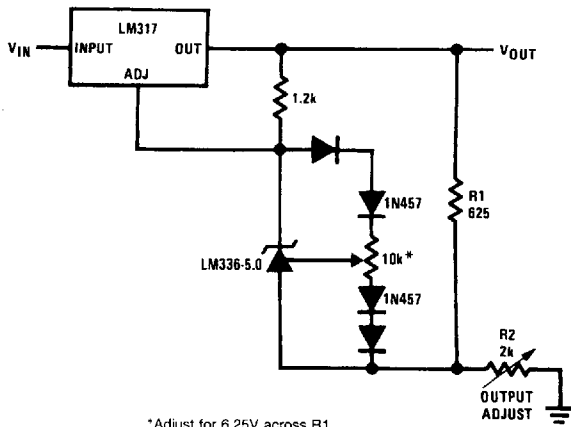

*Adjust for 6.25V across R1

TL/H/5716-11

Typical Applications (Continued)

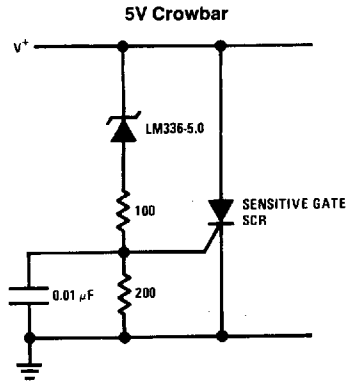

TL/H/5716-12

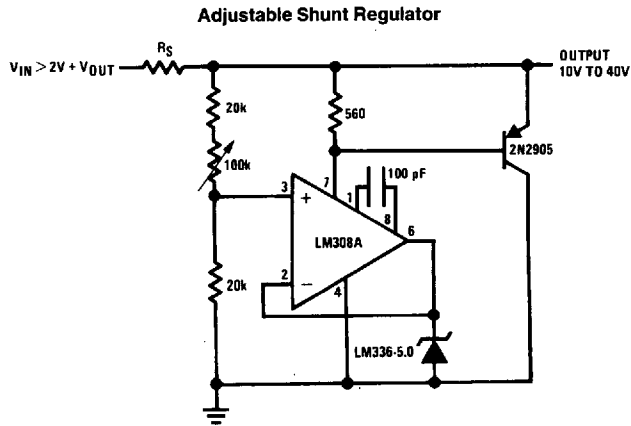

TL/H/5716-13

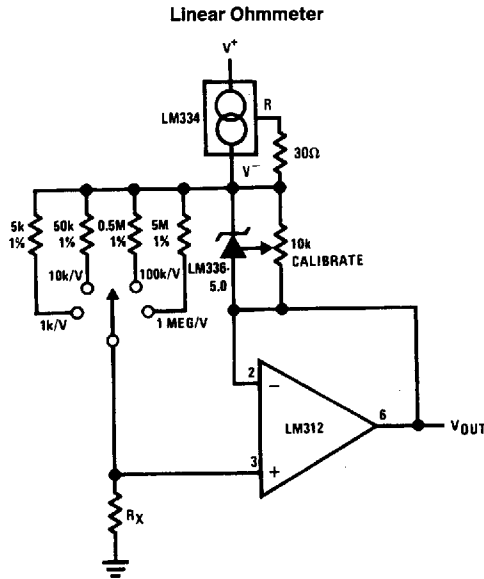

TL/H/5716-14

Typical Applications (Continued)

Op Amp with Output Clamped

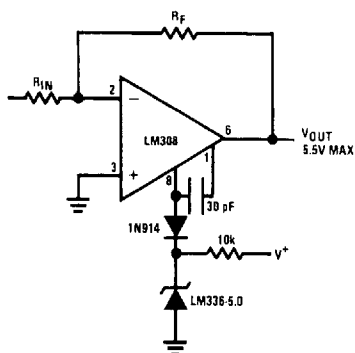

Bipolar Output Reference

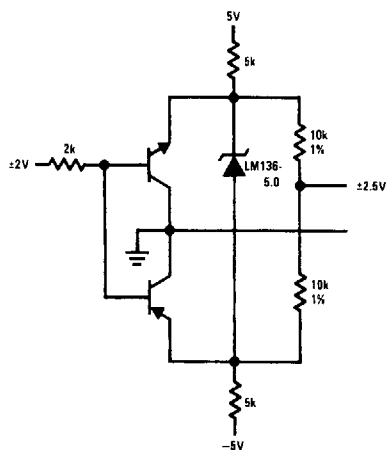

5.0V Square Wave Calibrator

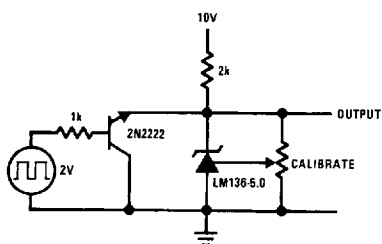

10V Buffered Reference

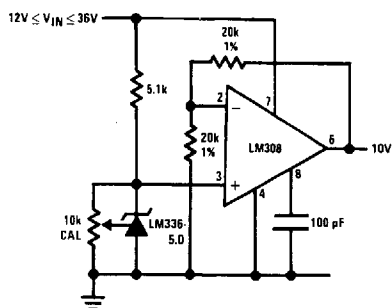

Low Noise Buffered Reference

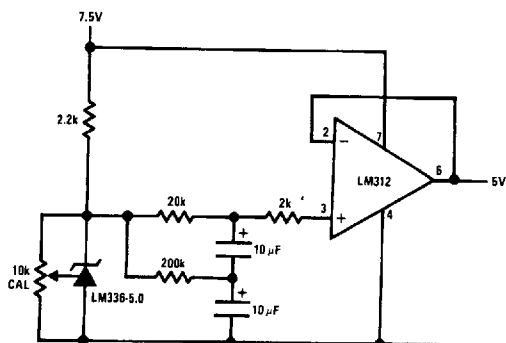

Wide Input Range Reference

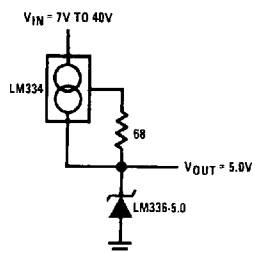

TL/H/5716-6

Schematic Diagram

