

Customer Information Sheet

DRAWING No.: M20-970XXXX

SHEET 2 OF 2

IF IN DOUBT - ASK



NOT TO SCALE

THIRD ANGLE PROJECTION

ALL DIMENSIONS IN mm

NOTES:

1. RECOMMENDED PCB MOUNTING HOLE SIZE = $\varnothing 1.00\text{mm}$.
2. ALL TOLERANCES ARE $\pm 0.25\text{mm}$ UNLESS OTHERWISE STATED.
3. FOR COMPLETE SPECIFICATION, SEE COMPONENT SPECIFICATION C001XX (LATEST ISSUE).

SPECIFICATION:

MATERIAL:
 MOULDING = HIGH TEMP NYLON 6T UL94V-0, BLACK
 PINS = BRASS
FINISH:
 PINS:
 45 = GOLD
 46 = 100% TIN OVER NICKEL
ELECTRICAL:
 CURRENT RATING = 3A MAX
 CONTACT RESISTANCE = 25 m Ω MAX (GOLD), 30 m Ω MAX (TIN)
 INSULATION RESISTANCE = 1,000 M Ω MIN
 DIELECTRIC STRENGTH = 750V AC/DC
MECHANICAL:
 DURABILITY = 300 OPERATIONS (GOLD), 50 OPERATIONS (TIN)
ENVIRONMENTAL:
 TEMPERATURE RANGE = -40°C TO +105°C
PACKING:
 BAG

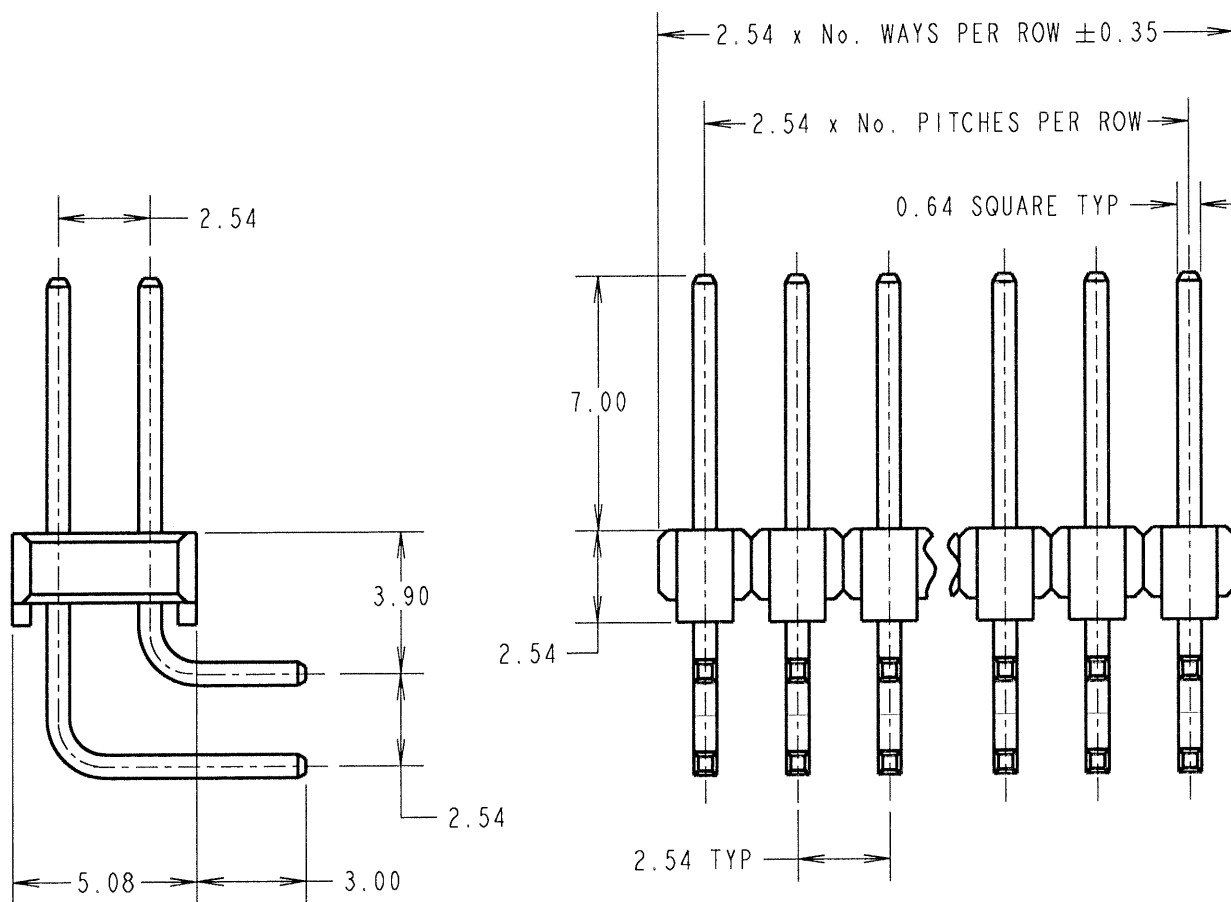

OBSOLETE

**No. of Contacts per Row:
 21, 23, 24, 26, 28 to 35, 37 to 39**

ORDER CODE:
M20-970XXXX
 No. OF WAYS: _____
 02 TO 40
 FINISH: _____
 45 = GOLD
 46 = 100% TIN

JMB	11	05.12.06	9602
NAME	ISS.	DATE	C/NOTE
APPROVED: <i>[Signature]</i>			
CHECKED: <i>[Signature]</i>			
DRAWN: D. FAIRS			
CUSTOMER REF.:			
ASSEMBLY DRG:			

HARWIN

HARWIN INC U.S.A. TEL: (812) 542 2540 FAX: (812) 542 2541	HARWIN PLC U.K. TEL: 023 9231 4545 FAX: 023 9231 4590	HARWIN PTE SINGAPORE TEL: 65 6779 4909 FAX: 65 6779 3868
--	--	---

THIS DRAWING AND ANY INFORMATION OR DESCRIPTIVE MATTER SET OUT HEREON ARE CONFIDENTIAL AND COPYRIGHT PROPERTY OF THE HARWIN GROUP AND MUST NOT BE DISCLOSED, LOANED, COPIED OR USED FOR MANUFACTURING, TENDERING OR FOR ANY OTHER PURPOSE WITHOUT THEIR WRITTEN PERMISSION.

TOLERANCES
~~mm = $\pm 1\text{mm}$~~
~~X.X = $\pm 0.25\text{mm}$~~
~~X.XX = $\pm 0.10\text{mm}$~~
~~X.XXX = $\pm 0.01\text{mm}$~~
 ANGLES = $\pm 5^\circ$
 UNLESS STATED

MATERIAL:
 SEE ABOVE
FINISH:
 SEE ABOVE
S/AREA: mm²

TITLE: 2.54mm PITCH SIL HORIZONTAL PC TAIL PIN HEADER ASSEMBLY
DRAWING NUMBER: M20-970XXXX
 SHT 2 OF 2