

2530 Series 2.54mm(.100") Crimp Terminal Socket

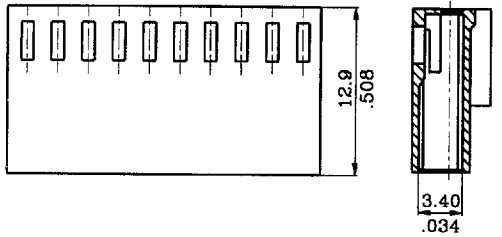

Unit : $\frac{\text{mm}}{\text{inch}}$

Dimensional & Ordering Information:

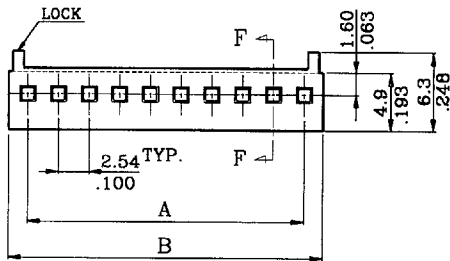

SECTION F-F

Circuits	Part No.		Dimension	
	With Lock	Without Lock	A	B
2	2530S020013	2530S020N13	2.54(.100)	5.70(.224)
3	2530S030013	2530S030N13	5.08(.200)	8.20(.323)
4	2530S040013	2530S040N13	7.62(.300)	10.80(.425)
5	2530S050013	2530S050N13	10.16(.400)	13.30(.524)
6	2530S060013	2530S060N13	12.70(.500)	15.90(.626)
7	2530S070013	2530S070N13	15.24(.600)	18.40(.724)
8	2530S080013	2530S080N13	17.78(.700)	20.90(.823)
9	2530S090013	2530S090N13	20.32(.800)	23.50(.925)
10	2530S100013	2530S100N13	22.86(.900)	26.00(1.024)
11	2530S110013	2530S110N13	25.40(1.000)	28.60(1.126)
12	2530S120013	2530S120N13	27.94(1.100)	31.10(1.224)
13	2530S130013	2530S130N13	30.48(1.200)	33.60(1.323)
14	2530S140013	2530S140N13	33.02(1.300)	36.20(1.425)
15	2530S150013	2530S150N13	35.56(1.400)	38.70(1.524)
16	2530S160013	2530S160N13	38.10(1.500)	41.30(1.626)
17	2530S170013	2530S170N13	40.64(1.600)	43.80(1.724)
18	2530S180013	2530S180N13	43.18(1.700)	46.30(1.823)
19	2530S190013	2530S190N13	45.72(1.800)	48.90(1.925)
20	2530S200013	2530S200N13	48.26(1.900)	51.40(2.024)

2533 Series Crimp Terminal



Unit : $\frac{\text{mm}}{\text{inch}}$

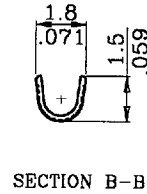
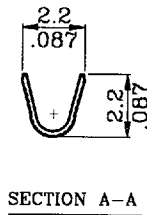
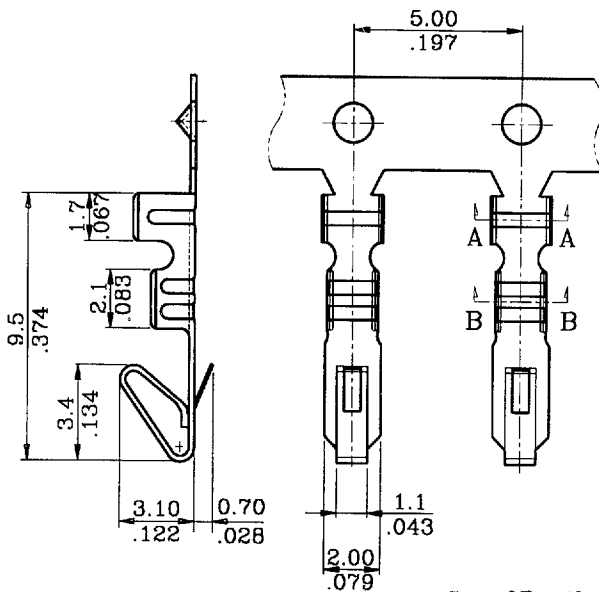

Specifications & Ordering Information:

Part No.	Wire Ranges	Insulation Diameter	Reel Q'ty	Tooling
2533TCB*000	AWG 22 ~ 28	1.50 (.059) MAX.	10,000PCS	CCD-2533R01

2430 Series 2.50mm(.098") Crimp Type Socket



Unit : $\frac{mm}{inch}$

Dimensional & Ordering Information:

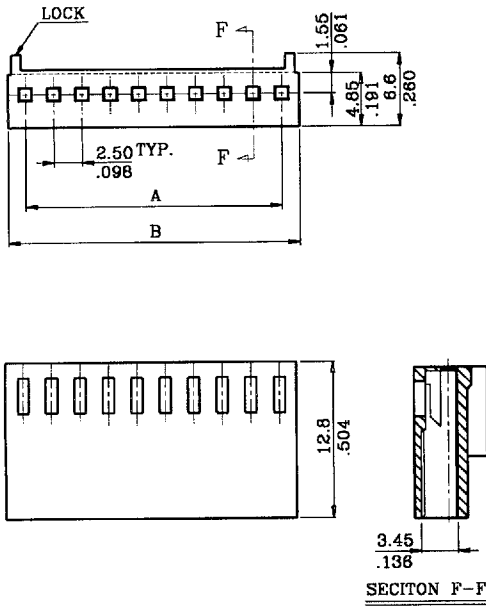

Circuits	Part No.		Dimension	
	With Lock	Without Lock	A	B
2	2430S020000	2430S020N00	2.50(.098)	5.50(.217)
3	2430S030000	2430S030N00	5.00(.197)	8.00(.315)
4	2430S040000	2430S040N00	7.50(.295)	10.50(.413)
5	2430S050000	2430S050N00	10.00(.394)	13.00(.512)
6	2430S060000	2430S060N00	12.50(.492)	15.50(.610)
7	2430S070000	2430S070N00	15.00(.591)	18.00(.709)
8	2430S080000	2430S080N00	17.50(.689)	20.50(.807)
9	2430S090000	2430S090N00	20.00(.787)	23.00(.906)
10	2430S100000	2430S100N00	22.50(.886)	25.50(1.004)
11	2430S110000	2430S110N00	25.00(.984)	28.00(1.102)
12	2430S120000	2430S120N00	27.50(1.083)	30.50(1.201)
13	2430S130000	2430S130N00	30.00(1.181)	33.00(1.299)
14	2430S140000	2430S140N00	32.50(1.280)	35.50(1.398)
15	2430S150000	2430S150N00	35.00(1.378)	38.00(1.496)
16	2430S160000	2430S160N00	37.50(1.476)	40.50(1.594)
17	2430S170000	2430S170N00	40.00(1.575)	43.00(1.693)
18	2430S180000	2430S180N00	42.50(1.673)	45.50(1.791)
19	2430S190000	2430S190N00	45.00(1.771)	48.00(1.890)
20	2430S200000	2430S200N00	47.50(1.870)	50.50(1.988)

2431 Series 2.50mm(.098") Header



Straight (V version)

Unit : $\frac{mm}{inch}$

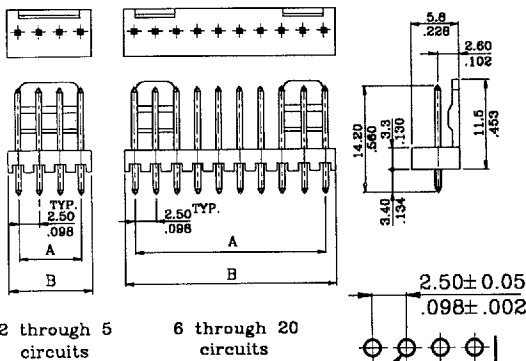

Right Angle (H version)

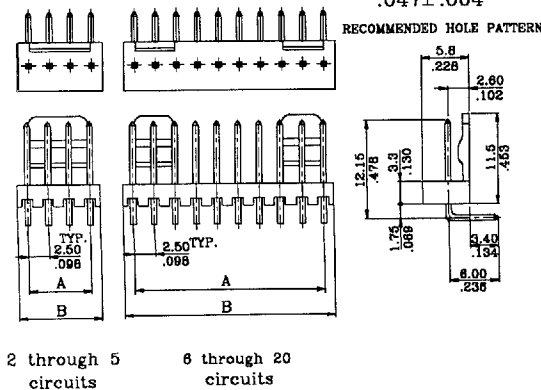

Dimensional & Ordering Information:

Circuits	Part No.		Dimension	
	Straight	Right Angle	A	B
2	2431P02V000	2431P02H000	2.50(.098)	5.00(.197)
3	2431P03V000	2431P03H000	5.00(.197)	7.50(.295)
4	2431P04V000	2431P04H000	7.50(.295)	10.00(.394)
5	2431P05V000	2431P05H000	10.00(.394)	12.50(.492)
6	2431P06V000	2431P06H000	12.50(.492)	15.00(.591)
7	2431P07V000	2431P07H000	15.00(.591)	17.50(.689)
8	2431P08V000	2431P08H000	17.50(.689)	20.00(.787)
9	2431P09V000	2431P09H000	20.00(.787)	22.50(.886)
10	2431P10V000	2431P10H000	22.50(.886)	25.00(.984)
11	2431P11V000	2431P11H000	25.00(.984)	27.50(1.083)
12	2431P12V000	2431P12H000	27.50(1.083)	30.00(1.181)
13	2431P13V000	2431P13H000	30.00(1.181)	32.50(1.280)
14	2431P14V000	2431P14H000	32.50(1.280)	35.00(1.378)
15	2431P15V000	2431P15H000	35.00(1.378)	37.50(1.476)
16	2431P16V000	2431P16H000	37.50(1.476)	40.00(1.575)
17	2431P17V000	2431P17H000	40.00(1.575)	42.50(1.673)
18	2431P18V000	2431P18H000	42.50(1.673)	45.00(1.772)
19	2431P19V000	2431P19H000	45.00(1.772)	47.50(1.870)
20	2431P20V000	2431P20H000	47.50(1.870)	50.00(1.969)