

OCTAL BUS BUFFER
TC74ACT540P/F/FW/FS INVERTING, 3-STATE OUTPUTS
TC74ACT541P/F/FW/FS NON-INVERTING, 3-STATE OUTPUTS

The TC74ACT540 / TC74ACT541 are advanced high speed CMOS OCTAL BUS BUFFERs fabricated with silicon gate and double-layer metal wiring C²MOS technology. They achieve the high speed operation similar to equivalent Bipolar Schottky TTL while maintaining the CMOS low power dissipation.

These devices may be used as a level converter for interfacing TTL or NMOS to High Speed CMOS. The inputs are compatible with TTL, NMOS and CMOS output voltage levels.

The TC74ACT540 is an inverting type, and the TC74ACT541 is a non-inverting type.

When either $\bar{G}1$ or $\bar{G}2$ are high, the terminal outputs are in the high-impedance state.

All inputs are equipped with protection circuits against static discharge or transient excess voltage.

FEATURES:

- High Speed..... $t_{pd} = 4.3ns$ (typ.) at $V_{CC} = 5V$
- Low Power Dissipation..... $I_{CC} = 8\mu A$ (Max.) at $T_a = 25^\circ C$
- Compatible with TTL outputs ... $V_{IL} = 0.8V$ (Max.)
 $V_{IH} = 2.0V$ (Min.)
- Symmetrical Output Impedance... $|I_{OH}| = I_{OL} = 24mA$ (Min.)
Capability of driving 50Ω transmission lines.
- Balanced Propagation Delays..... $t_{pLH} \approx t_{pHL}$
- Pin and Function Compatible with 74F540/541

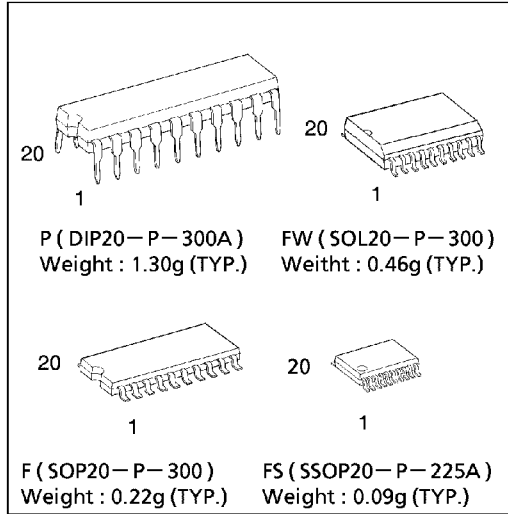

TRUTH TABLE

INPUTS			OUTPUTS	
$\bar{G}1$	$\bar{G}2$	An	Y_n^*	\bar{Y}_n^*
H	X	X	Z	Z
X	H	X	Z	Z
L	L	H	H	L
L	L	L	L	H

X : Don't Care
Z : High Impedance
* : Y_n ACT541
 \bar{Y}_n ACT540

PIN ASSIGNMENT

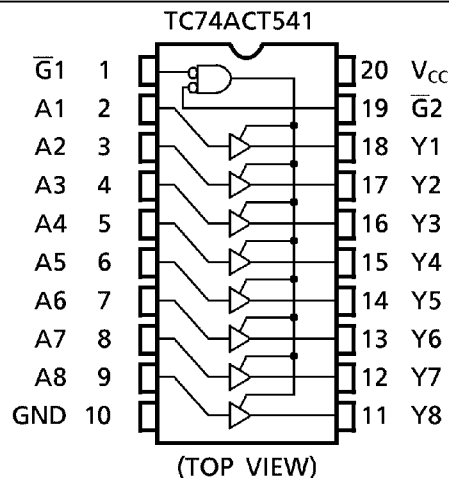
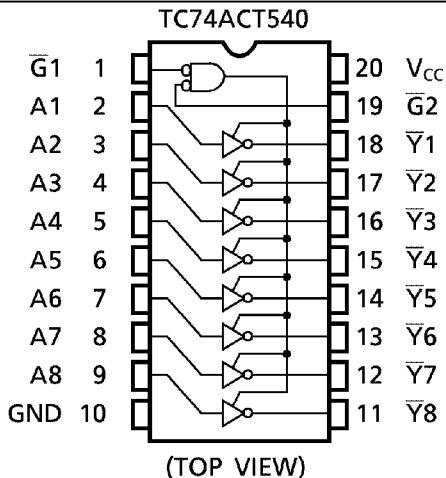

© The information contained herein is presented only as a guide for the applications of our products. No responsibility is assumed by TOSHIBA CORPORATION for any infringements of intellectual property or other rights of the third parties which may result from its use. No license is granted by implication or otherwise under any intellectual property or other rights of TOSHIBA CORPORATION or others.

© These TOSHIBA products are intended for use in general commercial applications (office equipment, communication equipment, measuring equipment, domestic appliances, etc.). please make sure that you consult with us before you use these TOSHIBA products in equipment which requires extraordinarily high quality and/or reliability, and in equipment which may involve life threatening or critical application, including but not limited to such uses as atomic energy control, airplane or spaceship instrumentation, traffic signals, medical instrumentation, combustion control, all types of safety devices, etc. TOSHIBA cannot accept and hereby disclaims liability for any damage which may occur in case the TOSHIBA products are used in such equipment or applications without prior consultation with TOSHIBA.

IEC LOGIC SYMBOL

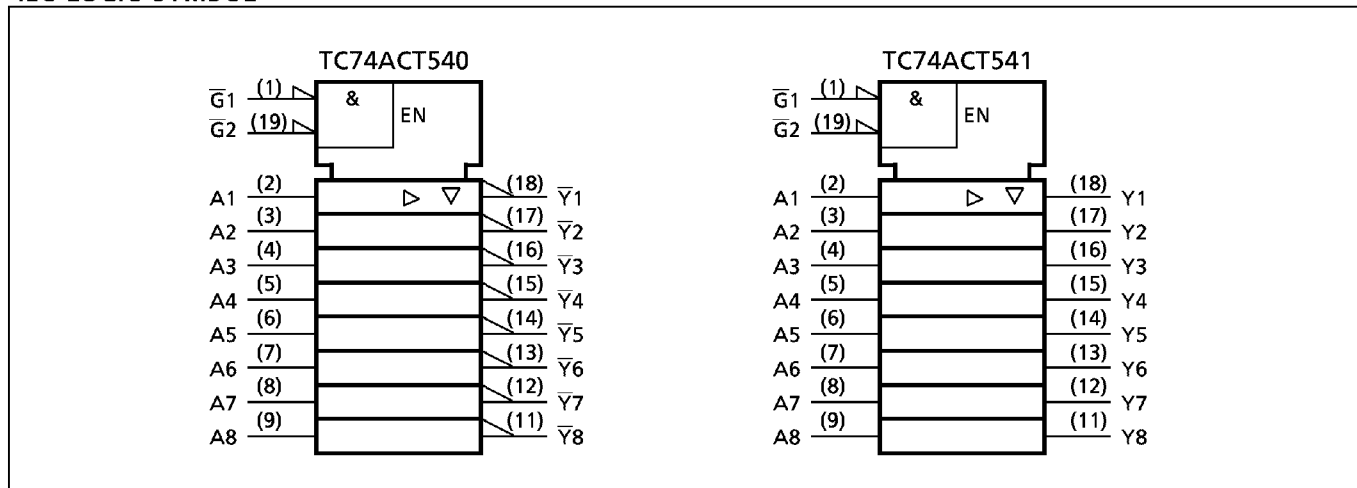

ABSOLUTE MAXIMUM RATINGS

PARAMETER	SYMBOL	VALUE	UNIT
Supply Voltage Range	V_{CC}	-0.5~7.0	V
DC Input Voltage	V_{IN}	-0.5~ $V_{CC} + 0.5$	V
DC Output Voltage	V_{OUT}	-0.5~ $V_{CC} + 0.5$	V
Input Diode Current	I_{IK}	± 20	mA
Output Diode Current	I_{OK}	± 50	mA
DC Output Current	I_{OUT}	± 50	mA
DC V_{CC} /Ground Current	I_{CC}	± 200	mA
Power Dissipation	P_D	500 (DIP)* / 180 (SOP / SSOP)	mW
Storage Temperature	T_{stg}	-65~150	°C

*500mW in the range of $T_a = -40^{\circ}\text{C} \sim 65^{\circ}\text{C}$. From $T_a = 65^{\circ}\text{C}$ to 85°C a derating factor of $-10\text{mW}/^{\circ}\text{C}$ should be applied up to 300mW.

RECOMMENDED OPERATING CONDITIONS

PARAMETER	SYMBOL	VALUE	UNIT
Supply Voltage	V_{CC}	4.5~5.5	V
Input Voltage	V_{IN}	0~ V_{CC}	V
Output Voltage	V_{OUT}	0~ V_{CC}	V
Operating Temperature	T_{opr}	-40~85	°C
Input Rise and Fall Time	dt/dV	0~10	ns/V

DC ELECTRICAL CHARACTERISTICS

PARAMETER	SYMBOL	TEST CONDITION	V _{CC} (V)	Ta = 25°C			Ta = -40~85°C		UNIT	
				MIN.	TYP.	MAX.	MIN.	MAX.		
High - Level Input Voltage	V _{IH}		4.5 } 5.5	2.0	—	—	2.0	—	V	
Low - Level Input Voltage	V _{IL}		4.5 } 5.5	—	—	0.8	—	0.8	V	
High - Level Output Voltage	V _{OH}	V _{IN} = V _{IH} or V _{IL}	I _{OH} = -50μA	4.5	4.4	4.5	—	4.4	—	V
			I _{OH} = -24mA	4.5	3.94	—	—	3.80	—	
			I _{OH} = -75mA*	5.5	—	—	—	3.85	—	
Low - Level Output Voltage	V _{OL}	V _{IN} = V _{IH} or V _{IL}	I _{OL} = 50μA	4.5	—	0.0	0.1	—	0.1	V
			I _{OL} = 24mA	4.5	—	—	0.36	—	0.44	
			I _{OL} = 75mA*	5.5	—	—	—	—	1.65	
3 - State Output Off - State Current	I _{OZ}	V _{IN} = V _{IH} or V _{IL} V _{OUT} = V _{CC} or GND	5.5	—	—	±0.5	—	±5.0	μA	
Input Leakage Current	I _{IN}	V _{IN} = V _{CC} or GND	5.5	—	—	±0.1	—	±1.0		
Quiescent Supply Current	I _{CC}	V _{IN} = V _{CC} or GND	5.5	—	—	8.0	—	80.0	mA	
	I _C	PER INPUT : V _{IN} = 3.4V OTHER INPUT : V _{CC} or GND	5.5	—	—	1.35	—	1.5		

* : This spec indicates the capability of driving 50Ω transmission lines.

One output should be tested at a time for a 10ms maximum duration.

AC ELECTRICAL CHARACTERISTICS (C_L = 50pF, R_L = 500Ω, Input t_r = t_f = 3ns)

PARAMETER	SYMBOL	TEST CONDITION	V _{CC} (V)	Ta = 25°C			Ta = -40~85°C		UNIT
				MIN.	TYP.	MAX.	MIN.	MAX.	
Propagation Delay Time *	t _{pLH} t _{pHL}		5.0 ± 0.5	—	5.0	8.3	1.0	9.5	ns
				—	5.0	8.3	1.0	9.5	
Propagation Delay Time**	t _{pLH} t _{pHL}		5.0 ± 0.5	—	5.0	8.3	1.0	9.5	
				—	5.0	8.3	1.0	9.5	
Output Enable Time	t _{pZL} t _{pZH}		5.0 ± 0.5	—	7.3	11.4	1.0	13.0	
				—	5.9	9.2	1.0	10.5	
Output Disable Time	t _{pLZ} t _{pHZ}		5.0 ± 0.5	—	5.9	9.2	1.0	10.5	
				—	5.9	9.2	1.0	10.5	
Input Capacitance	C _{IN}			—	5	10	—	10	pF
Output Capacitance	C _{OUT}			—	10	—	—	—	
Power Dissipation Capacitance	C _{PD} (1)	TC74ACT540		—	24	—	—	—	
		TC74ACT541		—	27	—	—	—	

Note (1) C_{PD} is defined as the value of the internal equivalent capacitance which is calculated from the operating current consumption without load.

Average operating current can be obtained by the equation :

$$I_{CC(opr.)} = C_{PD} \cdot V_{CC} \cdot f_{IN} + I_{CC} / 8 \text{ (per bit)}$$

(2) * for TC74ACT540 only

** for TC74ACT541 only

DIP 20PIN OUTLINE DRAWING (DIP20-P-300A)

Unit in mm

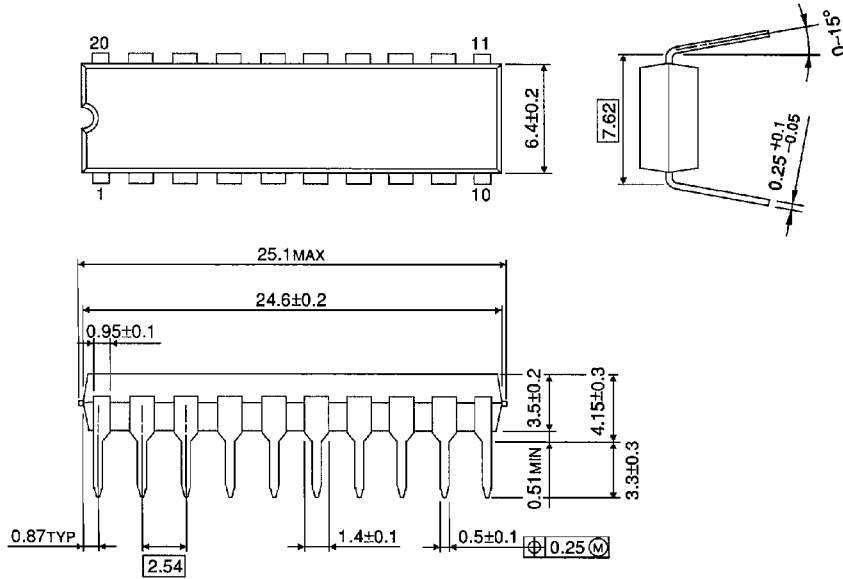

Weight: 1.30g (TYP.)

SOP 20PIN (200mil BODY) OUTLINE DRAWING (SOP20-P-300)

Unit in mm

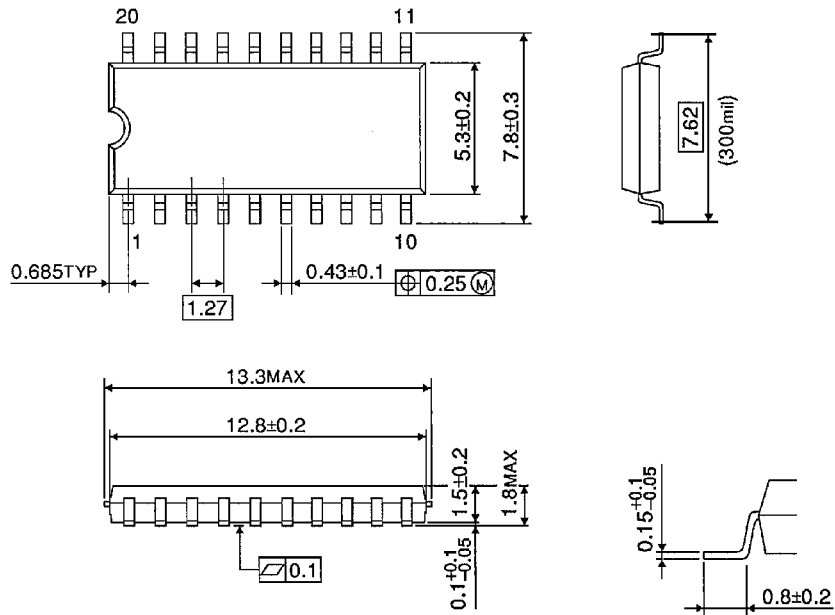

Weight: 0.22g (TYP.)

SOP 20PIN (300mil BODY) OUTLINE DRAWING (SOL20-P-300)

Unit in mm

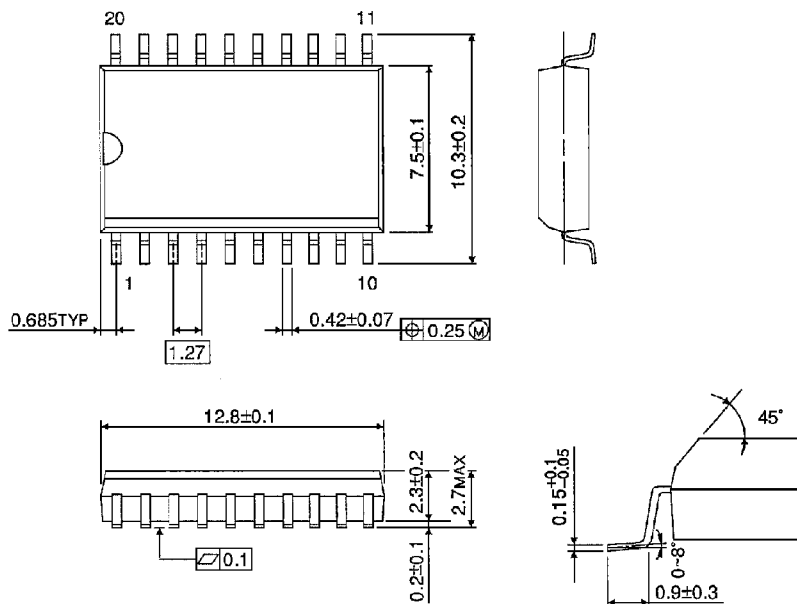

Weight: 0.46g (TYP.)

SSOP 20PIN OUTLINE DRAWING (SSOP20-P-225A)

Unit in mm

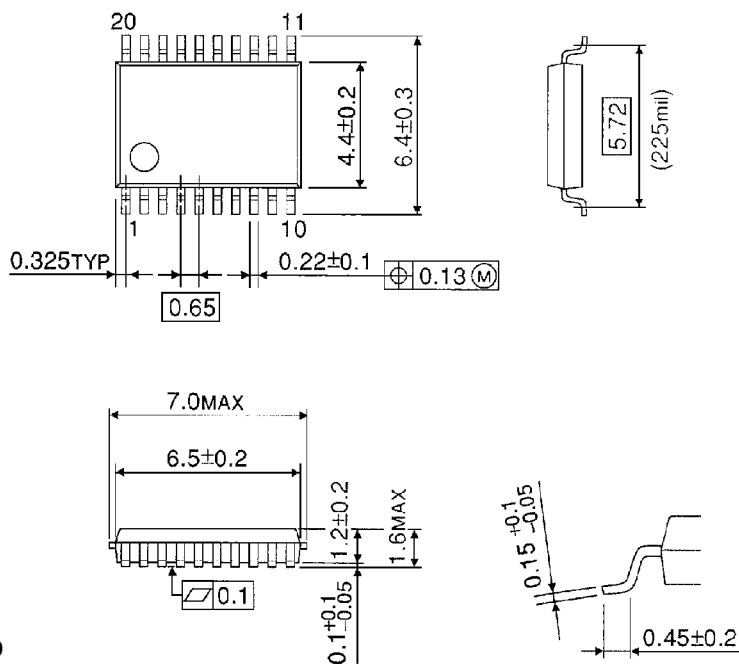

Weight: 0.09g (TYP.)