

DO NOT SCALE FROM THIS PRINT

TERMINAL SPEC	PIN #1	PIN #2	PIN #3
-05	T-1S6-21-X-2	N/A	N/A
-06	T-1S6-18-X-2	N/A	N/A
-07	T-1S6-07-X-2	T-1S6-15-X-2	T-1S6-10-X-2
-08	T-1S6-08-X-2	T-1S6-09-X-2	T-1S6-11-X-2
-09	T-1S6-09-X-2	T-1S6-11-X-2	T-1S6-20-X-2
-10	T-1S6-10-X-2	T-1S6-12-X-2	T-1S6-13-X-2
-11	T-1S6-11-X-2	T-1S6-20-X-2	T-1S6-19-X-2
-12	T-1S6-12-X-2	T-1S6-13-X-2	T-1S6-14-X-2
-13	T-1S6-13-X-2	T-1S6-14-X-2	N/A
-21	T-1S6-14-X-2	N/A	N/A
-22	T-1S6-15-X-2	T-1S6-10-X-2	T-1S6-12-X-2
-23	T-1S6-16-X-2	N/A	N/A
-24	T-1S6-17-X-2	N/A	N/A
-27	T-1S6-19-X-2	N/A	N/A
-28	T-1S6-20-X-2	T-1S6-19-X-2	N/A

LEAD STYLE	C MAXIMUM STRAIGHT	C MAXIMUM W/RA	C MAXIMUM W/RE
-05	.235 [5.97]	N/A	N/A
-06	.200 [5.08]	N/A	N/A
-07	.330 [8.38]	.130 [3.30]	N/A
-08	.430 [10.92]	.230 [5.84]	.130 [3.30]
-09	.630 [16.00]	.430 [10.92]	.330 [8.38]
-10	.730 [18.54]	.530 [13.46]	.430 [10.92]
-11	.830 [21.08]	.630 [16.00]	.530 [13.46]
-12	.930 [23.62]	.730 [18.54]	.630 [16.00]
-13	1.130 [28.70]	.930 [23.62]	.830 [21.08]
-21	1.330 [33.78]	1.130 [28.70]	1.030 [26.16]
-22	.530 [13.46]	.330 [8.38]	.230 [5.84]
-23	.345 [8.76]	.145 [3.68]	N/A
-24	.380 [9.65]	.180 [4.57]	N/A
-27	1.230 [31.24]	1.030 [26.16]	.930 [23.62]
-28	1.030 [26.16]	.830 [21.08]	.730 [18.54]

- NOTES:
1. TERMINAL PUSHOUT FORCE: 3 LBS. MIN.
  2. HEIGHT VARIATION BETWEEN ANY TWO ROWS SHALL BE .005 [.13] MAX (R.A. TAIL N/A).
  3. ASSEMBLE GOLD PLATE END AS SHOWN.
  4. NOTE DELETED
  5. (C) REPRESENTS CRITICAL DIMENSION.
  6. TOW & SWAY SPEC. OF 2° APPLIES TO ALL POSITIONS, POST & TAIL, IN ALL DIRECTIONS.
  7. -STL PLATING AVAILABLE IN LEAD STYLES -07, -08, -10, 16, 17 & 21. STRAIGHT THROUGH HOLE ONLY.
  8. ORIENTATE PINS TO REDUCE THE NUMBER OF BANDOLIER MARKS IN THE POST AREA. (SEE TABLE 6)
  9. NOTE DELETED
  10. MAXIMUM CUT FLASH: .010 [.25]
  11. TABLE 5 IS A REFERENCE FOR INDIVIDUAL PIN LENGTHS AS LISTED ON THE T-1S6 COMPONENT PRINT AND NOT THE TERMINAL SPEC IN TABLE 1 OR IN THE PART CALLOUT.

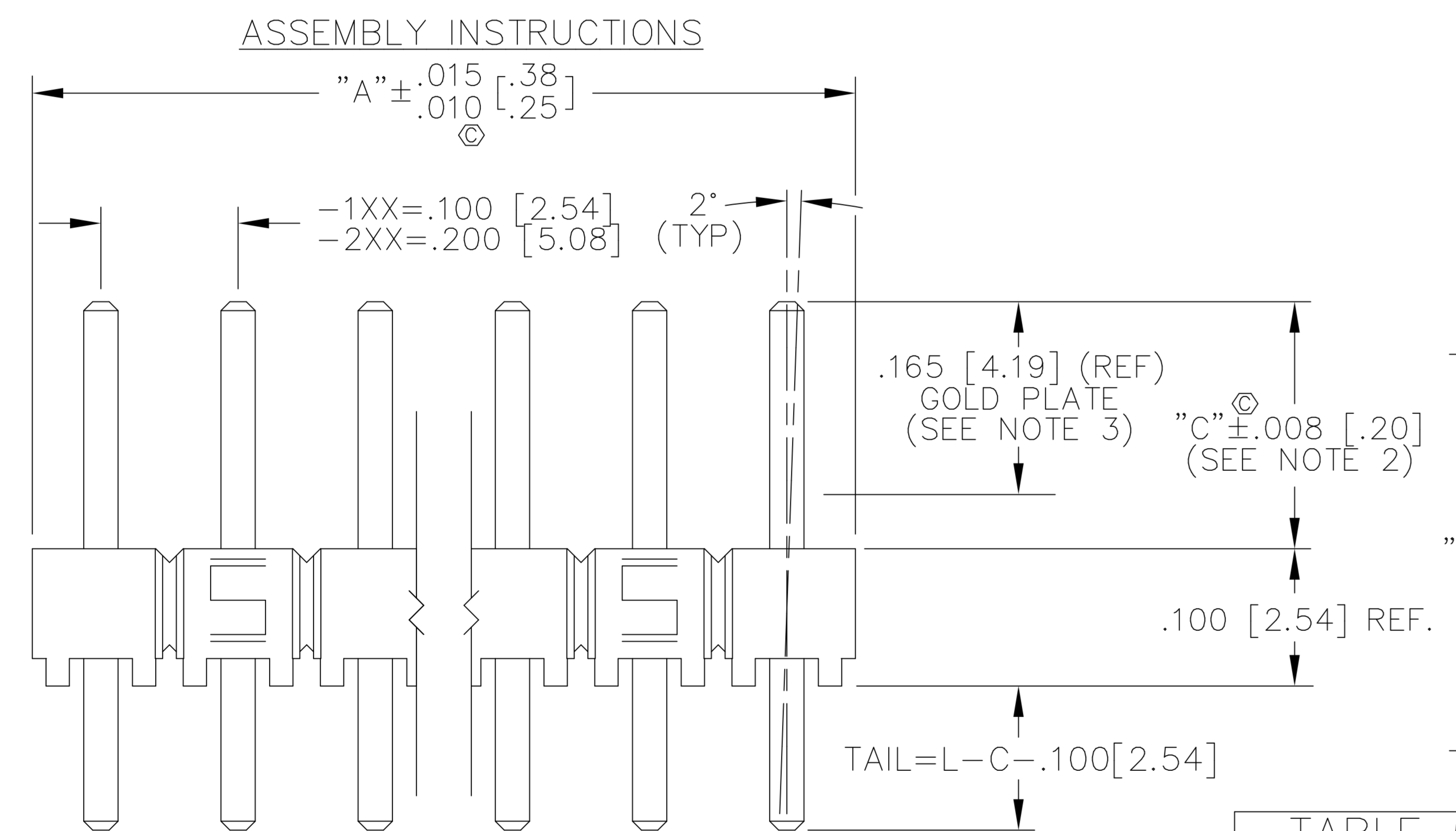
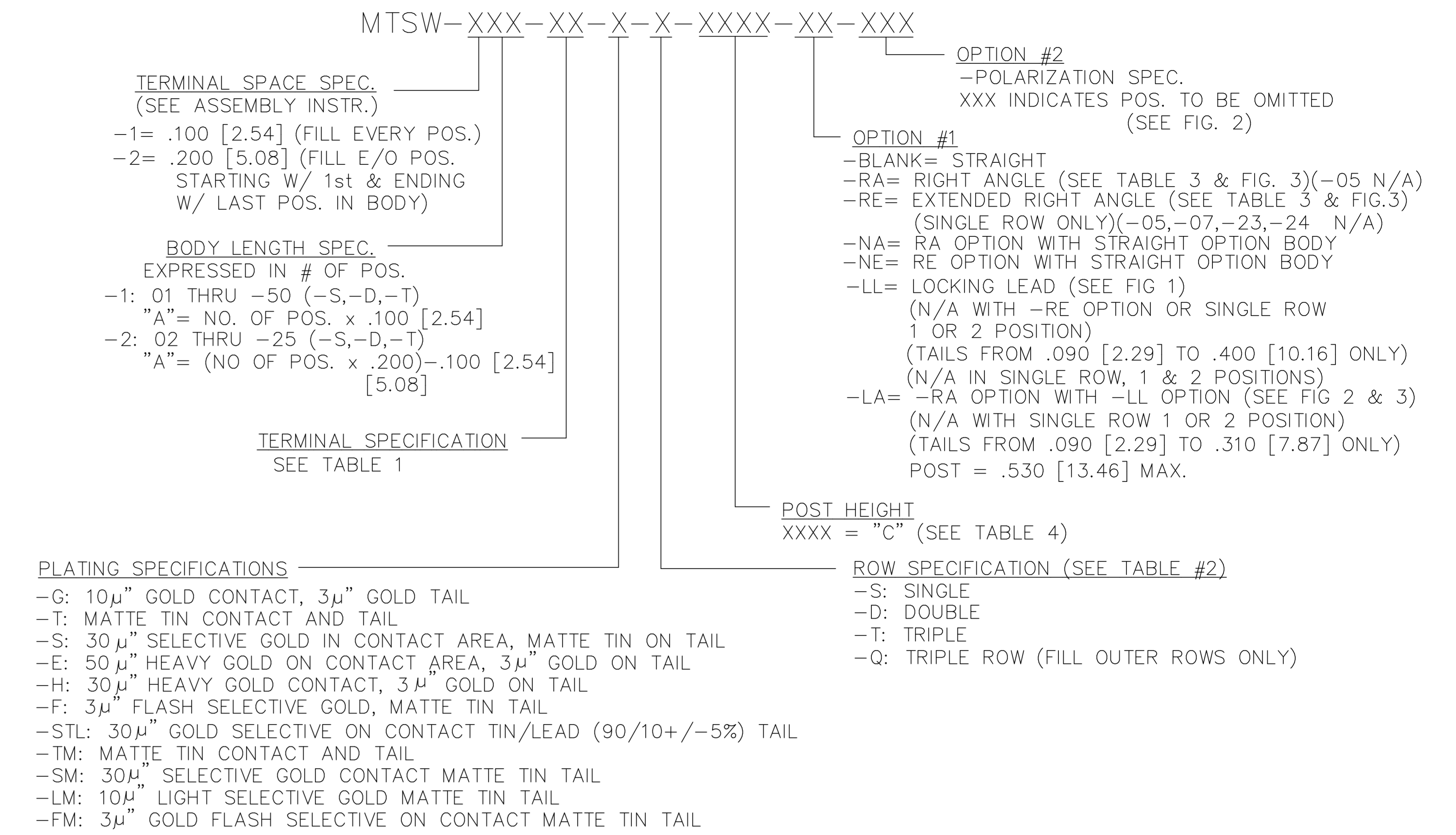

ROW/OPTION	USE BODY
-S/-S-NA/-S-NE	TSW-50-S
-S-RA/-S-RE	TSW-50-S-RA
-D/-D-NA/-D-NE	RTSW-50-D *
-D-RA	TSW-50-D-RA
-T/-T-NA/-T-NE	TSW-50-T
-T-RA	TSW-50-T-RA
-Q	TSW-50-T

-XX	"B"
-RA	.060 [1.52]
-RE	.160 [4.06]

LENGTH	"L"
-07	.430 [10.92]
-08	.530 [13.46]
-09	.730 [18.54]
-10	.830 [21.08]
-11	.930 [23.62]
-12	1.030 [26.16]
-13	1.230 [31.24]
-14	1.430 [36.32]
-15	.630 [16.00]
-16	.445 [11.30]
-17	.480 [12.19]
-18	.300 [7.62]
-19	1.330 [33.78]
-20	1.130 [28.70]
-21	.335 [8.51]

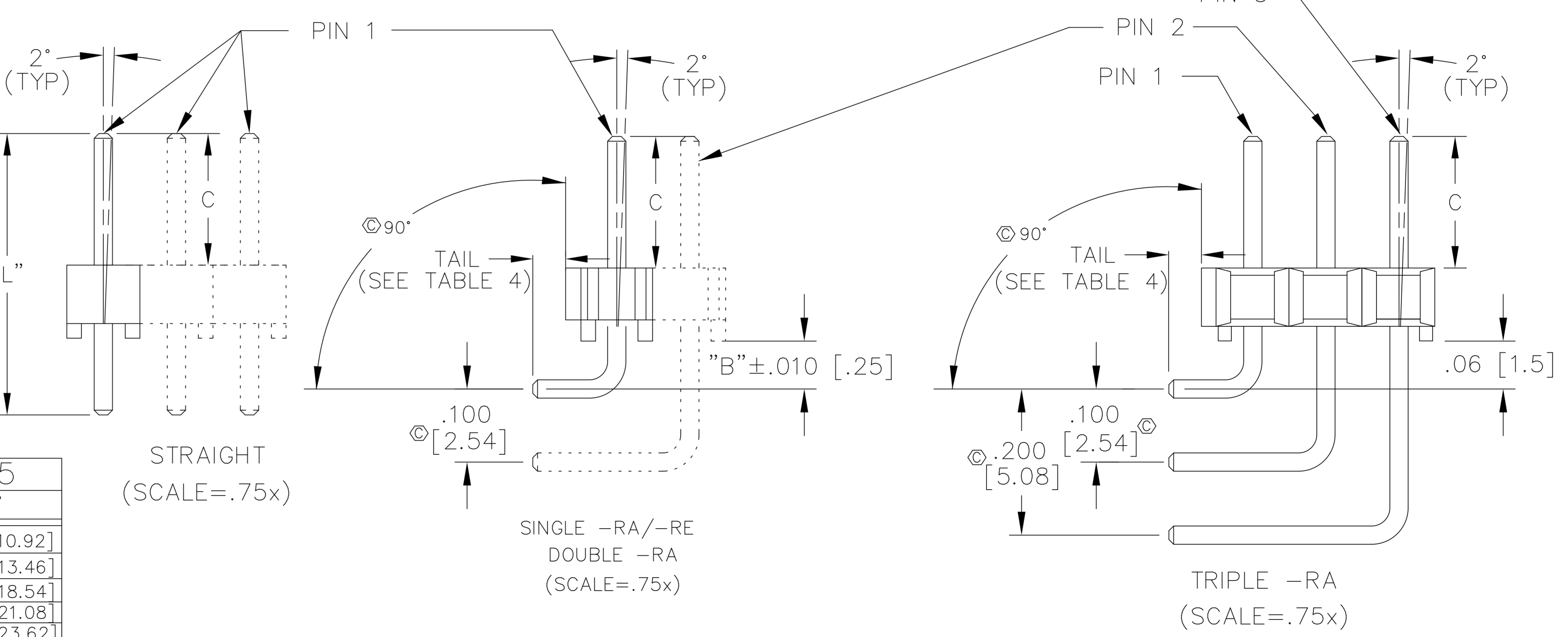

PROPRIETARY NOTE  
 THIS DOCUMENT CONTAINS INFORMATION CONFIDENTIAL AND PROPRIETARY TO SAMTEC INC. AND SHALL NOT BE REPRODUCED OR TRANSFERRED TO OTHER DOCUMENTS OR DISCLOSED TO OTHERS OR USED FOR ANY PURPOSE OTHER THAN THAT FOR WHICH IT WAS OBTAINED WITHOUT THE EXPRESSED WRITTEN CONSENT OF SAMTEC INC.

\* RTSW FOR HAND FILL. TSW FOR MACHINE FILL. TSW AND RTSW ARE INTERCHANGEABLE.  
 SEE NOTE 11  
 \* REF FOR PIN LENGTH, SHT 1

MATERIAL:  
 BODIES: GLASS FILLED POLYESTER  
 COLOR: BLACK  
 TERMINALS: PHOSPHOR BRONZE

**samtec**

520 PARK EAST BLVD. NEW ALBANY, INDIANA 47150  
 PHONE (812) 944-6733 P.O. BOX 1147  
 CODE 55322

MADE BY: PURVIS 2-17-87  
 MTSW-XXX-XX-X-X-XXXX-XX-XXX  
 SHEET 1 OF 3