

# MC10E256, MC100E256

## 5V ECL 3-Bit 4:1 Mux-Latch

The MC10E/100E256 contains three 4:1 multiplexers followed by transparent latches with differential outputs. Separate Select controls are provided for the leading 2:1 mux pairs (see logic symbol).

When the Latch Enable (LEN) is LOW, the latch is transparent, and output data is controlled by the multiplexer select controls. A logic HIGH on LEN latches the outputs. The Master Reset (MR) overrides all other controls to set the Q outputs LOW.

The 100 Series contains temperature compensation.

- 950 ps Max. D to Output
- 850 ps Max. LEN to Output
- Split Select
- Differential Outputs
- PECL Mode Operating Range:  $V_{CC}= 4.2\text{ V to }5.7\text{ V}$  with  $V_{EE}= 0\text{ V}$
- NECL Mode Operating Range:  $V_{CC}= 0\text{ V}$  with  $V_{EE}= -4.2\text{ V to }-5.7\text{ V}$
- Internal Input Pulldown Resistors
- ESD Protection:  $> 1\text{ KV HBM}$ ,  $> 75\text{ V MM}$
- Meets or Exceeds JEDEC Spec EIA/JESD78 IC Latchup Test
- Moisture Sensitivity Level 1
- For Additional Information, see Application Note AND8003/D
- Flammability Rating: UL-94 code V-0 @ 1/8", Oxygen Index 28 to 34
- Transistor Count = 280 devices



ON Semiconductor™

<http://onsemi.com>

### MARKING DIAGRAMS

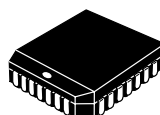

PLCC-28  
FN SUFFIX  
CASE 776

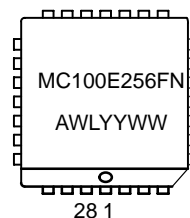
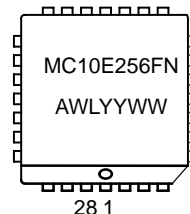

A = Assembly Location  
WL = Wafer Lot  
YY = Year  
WW = Work Week

### ORDERING INFORMATION

Device	Package	Shipping
MC10E256FN	PLCC-28	37 Units/Rail
MC10E256FNR2	PLCC-28	500 Units/Reel
MC100E256FN	PLCC-28	37 Units/Rail
MC100E256FNR2	PLCC-28	500 Units/Reel

# MC10E256, MC100E256

## LOGIC DIAGRAM AND PINOUT ASSIGNMENT

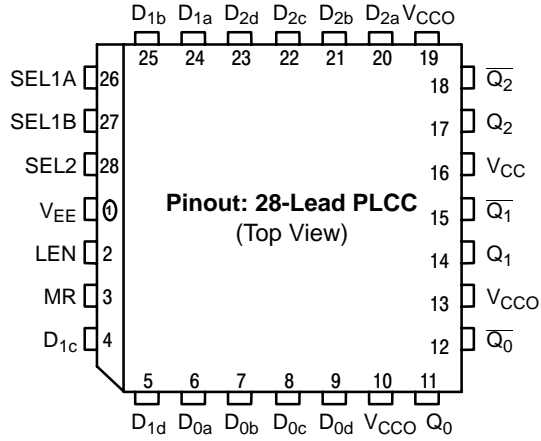

\* All  $V_{CC}$  and  $V_{CCO}$  pins are tied together on the die.  
Warning: All  $V_{CC}$ ,  $V_{CCO}$ , and  $V_{EE}$  pins must be externally connected to Power Supply to guarantee proper operation.

## PIN DESCRIPTION

PIN	FUNCTION
$D_{0x} - D_{2x}$	ECL Data Inputs
SEL1A, SEL1B	ECL First-stage Select Inputs
SEL2	ECL Second-stage Select Input
LEN	ECL Latch Enable
MR	ECL Master Reset
$Q_0, \overline{Q_0} - Q_2, \overline{Q_2}$	ECL Data Outputs
$V_{CC}, V_{CCO}$	Positive Supply
$V_{EE}$	Negative Supply

## FUNCTION TABLE

Pin	State	Operation
SEL2	H	Output c/d Data
SEL1A	H	Input d Data
SEL1B	H	Input b Data

## LOGIC DIAGRAM

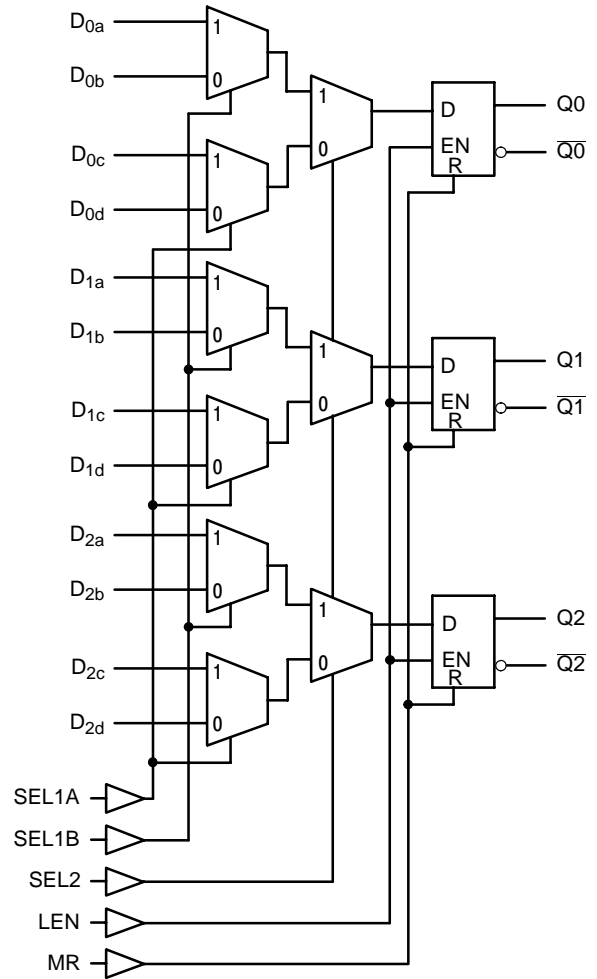

# MC10E256, MC100E256

## MAXIMUM RATINGS (Note 1.)

Symbol	Parameter	Condition 1	Condition 2	Rating	Units
V <sub>CC</sub>	PECL Mode Power Supply	V <sub>EE</sub> = 0 V		8	V
V <sub>EE</sub>	NECL Mode Power Supply	V <sub>CC</sub> = 0 V		-8	V
V <sub>I</sub>	PECL Mode Input Voltage NECL Mode Input Voltage	V <sub>EE</sub> = 0 V V <sub>CC</sub> = 0 V	V <sub>I</sub> ≤ V <sub>CC</sub> V <sub>I</sub> ≥ V <sub>EE</sub>	6 -6	V V
I <sub>out</sub>	Output Current	Continuous Surge		50 100	mA mA
T <sub>A</sub>	Operating Temperature Range			0 to +85	°C
T <sub>stg</sub>	Storage Temperature Range			-65 to +150	°C
θ <sub>JA</sub>	Thermal Resistance (Junction to Ambient)	0 LFPM 500 LFPM	28 PLCC 28 PLCC	63.5 43.5	°C/W °C/W
θ <sub>JC</sub>	Thermal Resistance (Junction to Case)	std bd	28 PLCC	22 to 26	°C/W
V <sub>EE</sub>	PECL Operating Range NECL Operating Range			4.2 to 5.7 -5.7 to -4.2	V V
T <sub>sol</sub>	Wave Solder	<2 to 3 sec @ 248°C		265	°C

1. Maximum Ratings are those values beyond which device damage may occur.

## 10E SERIES PECL DC CHARACTERISTICS V<sub>CCx</sub>= 5.0 V; V<sub>EE</sub>= 0.0 V (Note 1.)

Symbol	Characteristic	0°C			25°C			85°C			Unit
		Min	Typ	Max	Min	Typ	Max	Min	Typ	Max	
I <sub>EE</sub>	Power Supply Current		69	83		69	83		69	83	mA
V <sub>OH</sub>	Output HIGH Voltage (Note 2.)	3980	4070	4160	4020	4105	4190	4090	4185	4280	mV
V <sub>OL</sub>	Output LOW Voltage (Note 2.)	3050	3210	3370	3050	3210	3370	3050	3227	3405	mV
V <sub>IH</sub>	Input HIGH Voltage	3830	3995	4160	3870	4030	4190	3940	4110	4280	mV
V <sub>IL</sub>	Input LOW Voltage	3050	3285	3520	3050	3285	3520	3050	3302	3555	mV
I <sub>IH</sub>	Input HIGH Current			150			150			150	μA
I <sub>IL</sub>	Input LOW Current	0.5	0.3		0.5	0.25		0.3	0.2		μA

NOTE: Devices are designed to meet the DC specifications shown in the above table, after thermal equilibrium has been established. The circuit is in a test socket or mounted on a printed circuit board and transverse air flow greater than 500 lpm is maintained.

1. Input and output parameters vary 1:1 with V<sub>CC</sub>. V<sub>EE</sub> can vary +0.46 V / -0.06 V.
2. Outputs are terminated through a 50 ohm resistor to V<sub>CC</sub>-2 volts.

## 10E SERIES NECL DC CHARACTERISTICS V<sub>CCx</sub>= 0.0 V; V<sub>EE</sub>= -5.0 V (Note 1.)

Symbol	Characteristic	0°C			25°C			85°C			Unit
		Min	Typ	Max	Min	Typ	Max	Min	Typ	Max	
I <sub>EE</sub>	Power Supply Current		69	83		69	83		69	83	mA
V <sub>OH</sub>	Output HIGH Voltage (Note 2.)	-1020	-930	-840	-980	-895	-810	-910	-815	-720	mV
V <sub>OL</sub>	Output LOW Voltage (Note 2.)	-1950	-1790	-1630	-1950	-1790	-1630	-1950	-1773	-1595	mV
V <sub>IH</sub>	Input HIGH Voltage	-1170	-1005	-840	-1130	-970	-810	-1060	-890	-720	mV
V <sub>IL</sub>	Input LOW Voltage	-1950	-1715	-1480	-1950	-1715	-1480	-1950	-1698	-1445	mV
I <sub>IH</sub>	Input HIGH Current			150			150			150	μA
I <sub>IL</sub>	Input LOW Current	0.5	0.3		0.5	0.065		0.3	0.2		μA

NOTE: Devices are designed to meet the DC specifications shown in the above table, after thermal equilibrium has been established. The circuit is in a test socket or mounted on a printed circuit board and transverse air flow greater than 500 lpm is maintained.

1. Input and output parameters vary 1:1 with V<sub>CC</sub>. V<sub>EE</sub> can vary +0.46 V / -0.06 V.
2. Outputs are terminated through a 50 ohm resistor to V<sub>CC</sub>-2 volts.

# MC10E256, MC100E256

## 100E SERIES PECL DC CHARACTERISTICS $V_{CCx}=5.0\text{ V}; V_{EE}=0.0\text{ V}$ (Note 1.)

Symbol	Characteristic	0°C			25°C			85°C			Unit
		Min	Typ	Max	Min	Typ	Max	Min	Typ	Max	
$I_{EE}$	Power Supply Current		69	83		69	83		79	96	mA
$V_{OH}$	Output HIGH Voltage (Note 2.)	3975	4050	4120	3975	4050	4120	3975	4050	4120	mV
$V_{OL}$	Output LOW Voltage (Note 2.)	3190	3295	3380	3190	3255	3380	3190	3260	3380	mV
$V_{IH}$	Input HIGH Voltage	3835	4050	4120	3835	4120	4120	3835	4120	4120	mV
$V_{IL}$	Input LOW Voltage	3190	3300	3525	3190	3525	3525	3190	3525	3525	mV
$I_{IH}$	Input HIGH Current			150			150			150	$\mu\text{A}$
$I_{IL}$	Input LOW Current	0.5	0.3		0.5	0.25		0.5	0.2		$\mu\text{A}$

NOTE: Devices are designed to meet the DC specifications shown in the above table, after thermal equilibrium has been established. The circuit is in a test socket or mounted on a printed circuit board and transverse air flow greater than 500 lfm is maintained.

1. Input and output parameters vary 1:1 with  $V_{CC}$ .  $V_{EE}$  can vary +0.46 V / -0.8 V.
2. Outputs are terminated through a 50 ohm resistor to  $V_{CC}-2$  volts.

## 100E SERIES NECL DC CHARACTERISTICS $V_{CCx}=0.0\text{ V}; V_{EE}=-5.0\text{ V}$ (Note 1.)

Symbol	Characteristic	0°C			25°C			85°C			Unit
		Min	Typ	Max	Min	Typ	Max	Min	Typ	Max	
$I_{EE}$	Power Supply Current		69	83		69	83		79	96	mA
$V_{OH}$	Output HIGH Voltage (Note 2.)	-1025	-950	-880	-1025	-950	-880	-1025	-950	-880	mV
$V_{OL}$	Output LOW Voltage (Note 2.)	-1810	-1705	-1620	-1810	-1745	-1620	-1810	-1740	-1620	mV
$V_{IH}$	Input HIGH Voltage	-1165	-950	-880	-1165	-880	-880	-1165	-880	-880	mV
$V_{IL}$	Input LOW Voltage	-1810	-1700	-1475	-1810	-1475	-1475	-1810	-1475	-1475	mV
$I_{IH}$	Input HIGH Current			150			150			150	$\mu\text{A}$
$I_{IL}$	Input LOW Current	0.5	0.3		0.5	0.25		0.5	0.2		$\mu\text{A}$

NOTE: Devices are designed to meet the DC specifications shown in the above table, after thermal equilibrium has been established. The circuit is in a test socket or mounted on a printed circuit board and transverse air flow greater than 500 lfm is maintained.

1. Input and output parameters vary 1:1 with  $V_{CC}$ .  $V_{EE}$  can vary +0.46 V / -0.8 V.
2. Outputs are terminated through a 50 ohm resistor to  $V_{CC}-2$  volts.

## AC CHARACTERISTICS $V_{CCx}=5.0\text{ V}; V_{EE}=0.0\text{ V}$ or $V_{CCx}=0.0\text{ V}; V_{EE}=-5.0\text{ V}$ (Note 1.)

Symbol	Characteristic	0°C			25°C			85°C			Unit
		Min	Typ	Max	Min	Typ	Max	Min	Typ	Max	
$f_{MAX}$	Maximum Toggle Frequency		TBD			TBD			TBD		GHz
$t_{PLH}$ $t_{PHL}$	Propagation Delay to Output										ps
	D	400	600	900	400	600	900	400	600	900	
	SEL1	550	775	1050	550	775	1050	550	775	1050	
	SEL2	450	650	900	450	650	900	450	650	900	
	LEN MR	350 350	500 600	800 825	350 350	500 600	800 825	350 350	500 600	800 825	
$t_s$	Setup Time										ps
	D	400	275		400	275		400	275		
	SEL1 SEL2	600 500	300 250		600 500	300 250		600 500	300 250		
$t_h$	Hold Time										ps
	D	300	-275		300	-275		300	-275		
	SEL1 SEL2	100 200	-300 -250		100 200	-300 -250		100 200	-300 -250		
$t_{RR}$	Reset Recovery Time	700	600		700	600		700	600		ps
$t_{PW}$	Minimum Pulse Width				400			400			ps
	MR	400			400			400			
$t_{SKEW}$	Within-Device Skew (Note 2.)		50			50			50		ps
$t_{JITTER}$	Cycle-to-Cycle Jitter		TBD			TBD			TBD		ps
$t_r$ $t_f$	Rise/Fall Times (20 - 80%)	275	475	700	275	475	700	275	475	700	ps

1. 10 Series:  $V_{EE}$  can vary +0.46 V / -0.06 V.  
100 Series:  $V_{EE}$  can vary +0.46 V / -0.8 V.
2. Within-device skew is defined as identical transitions on similar paths through a device.

## MC10E256, MC100E256

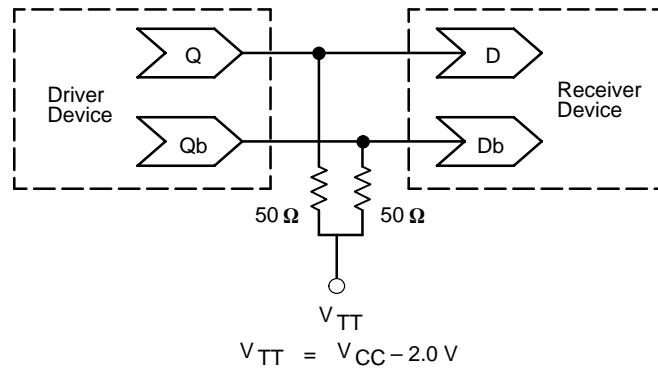

**Figure 1. Typical Termination for Output Driver and Device Evaluation**  
(See Application Note AND8020 – Termination of ECL Logic Devices.)

### Resource Reference of Application Notes

- AN1404** – ECLinPS Circuit Performance at Non-Standard  $V_{IH}$  Levels
- AN1405** – ECL Clock Distribution Techniques
- AN1406** – Designing with PECL (ECL at +5.0 V)
- AN1503** – ECLinPS I/O SPICE Modeling Kit
- AN1504** – Metastability and the ECLinPS Family
- AN1568** – Interfacing Between LVDS and ECL
- AN1596** – ECLinPS Lite Translator ELT Family SPICE I/O Model Kit
- AN1650** – Using Wire-OR Ties in ECLinPS Designs
- AN1672** – The ECL Translator Guide
- AND8001** – Odd Number Counters Design
- AND8002** – Marking and Date Codes
- AND8020** – Termination of ECL Logic Devices

# MC10E256, MC100E256

## PACKAGE DIMENSIONS

PLCC-28  
FN SUFFIX  
PLASTIC PLCC PACKAGE  
CASE 776-02  
ISSUE E

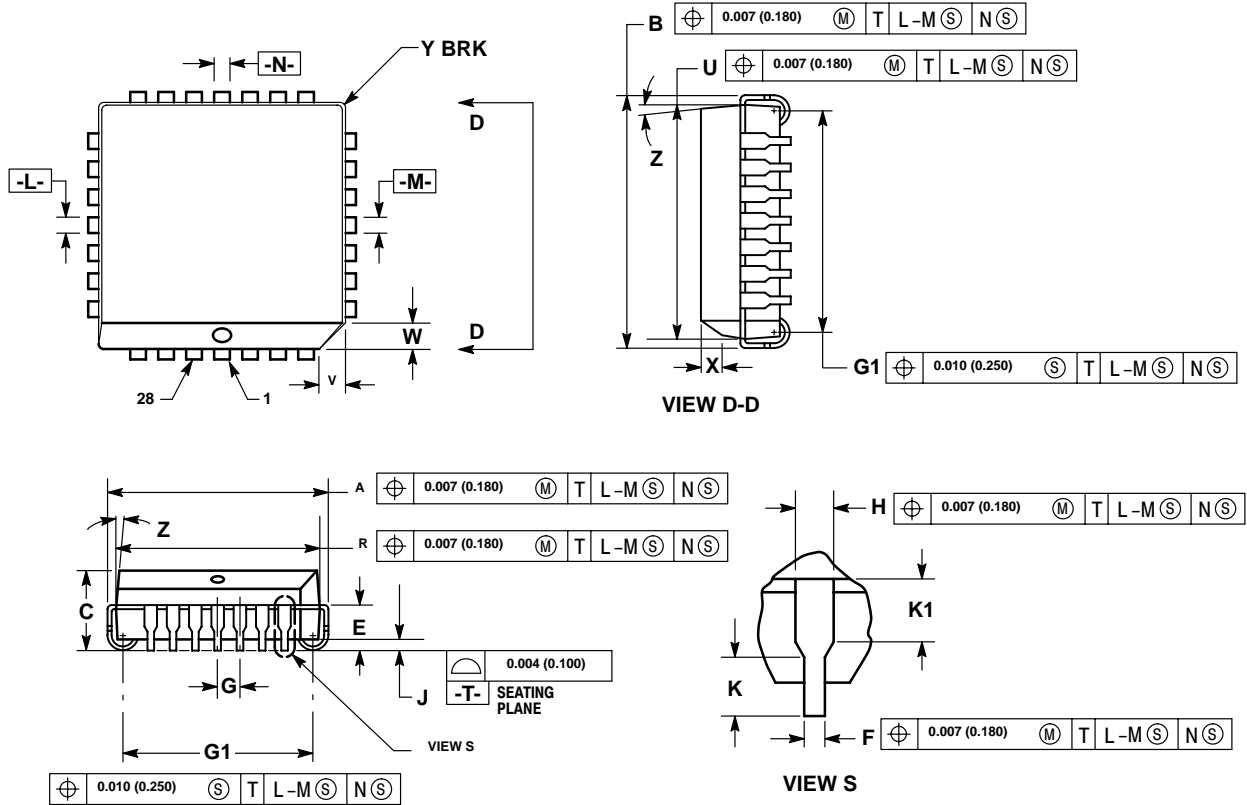

**NOTES:**

- DATUMS -L-, -M-, AND -N- DETERMINED WHERE TOP OF LEAD SHOULDER EXITS PLASTIC BODY AT MOLD PARTING LINE.
- DIM G1, TRUE POSITION TO BE MEASURED AT DATUM -T-, SEATING PLANE.
- DIM R AND U DO NOT INCLUDE MOLD FLASH. ALLOWABLE MOLD FLASH IS 0.010 (0.250) PER SIDE.
- DIMENSIONING AND TOLERANCING PER ANSI Y14.5M, 1982.
- CONTROLLING DIMENSION: INCH.
- THE PACKAGE TOP MAY BE SMALLER THAN THE PACKAGE BOTTOM BY UP TO 0.012 (0.300). DIMENSIONS R AND U ARE DETERMINED AT THE OUTERMOST EXTREMES OF THE PLASTIC BODY EXCLUSIVE OF MOLD FLASH, TIE BAR BURRS, GATE BURRS AND INTERLEAD FLASH, BUT INCLUDING ANY MISMATCH BETWEEN THE TOP AND BOTTOM OF THE PLASTIC BODY.
- DIMENSION H DOES NOT INCLUDE DAMBAR PROTRUSION OR INTRUSION. THE DAMBAR PROTRUSION(S) SHALL NOT CAUSE THE H DIMENSION TO BE GREATER THAN 0.037 (0.940). THE DAMBAR INTRUSION(S) SHALL NOT CAUSE THE H DIMENSION TO BE SMALLER THAN 0.025 (0.635).

DIM	INCHES		MILLIMETERS	
	MIN	MAX	MIN	MAX
A	0.485	0.495	12.32	12.57
B	0.485	0.495	12.32	12.57
C	0.165	0.180	4.20	4.57
E	0.090	0.110	2.29	2.79
F	0.013	0.019	0.33	0.48
G	0.050 BSC		1.27 BSC	
H	0.026	0.032	0.66	0.81
J	0.020	—	0.51	—
K	0.025	—	0.64	—
R	0.450	0.456	11.43	11.58
U	0.450	0.456	11.43	11.58
V	0.042	0.048	1.07	1.21
W	0.042	0.048	1.07	1.21
X	0.042	0.056	1.07	1.42
Y	—	0.020	—	0.50
Z	2°	10°	2°	10°
G1	0.410	0.430	10.42	10.92
K1	0.040	—	1.02	—

## Notes

**ON Semiconductor** and  are trademarks of Semiconductor Components Industries, LLC (SCILLC). SCILLC reserves the right to make changes without further notice to any products herein. SCILLC makes no warranty, representation or guarantee regarding the suitability of its products for any particular purpose, nor does SCILLC assume any liability arising out of the application or use of any product or circuit, and specifically disclaims any and all liability, including without limitation special, consequential or incidental damages. "Typical" parameters which may be provided in SCILLC data sheets and/or specifications can and do vary in different applications and actual performance may vary over time. All operating parameters, including "Typicals" must be validated for each customer application by customer's technical experts. SCILLC does not convey any license under its patent rights nor the rights of others. SCILLC products are not designed, intended, or authorized for use as components in systems intended for surgical implant into the body, or other applications intended to support or sustain life, or for any other application in which the failure of the SCILLC product could create a situation where personal injury or death may occur. Should Buyer purchase or use SCILLC products for any such unintended or unauthorized application, Buyer shall indemnify and hold SCILLC and its officers, employees, subsidiaries, affiliates, and distributors harmless against all claims, costs, damages, and expenses, and reasonable attorney fees arising out of, directly or indirectly, any claim of personal injury or death associated with such unintended or unauthorized use, even if such claim alleges that SCILLC was negligent regarding the design or manufacture of the part. SCILLC is an Equal Opportunity/Affirmative Action Employer.

## PUBLICATION ORDERING INFORMATION

### **NORTH AMERICA Literature Fulfillment:**

Literature Distribution Center for ON Semiconductor  
P.O. Box 5163, Denver, Colorado 80217 USA  
**Phone:** 303-675-2175 or 800-344-3860 Toll Free USA/Canada  
**Fax:** 303-675-2176 or 800-344-3867 Toll Free USA/Canada  
**Email:** ONlit@hibbertco.com  
Fax Response Line: 303-675-2167 or 800-344-3810 Toll Free USA/Canada

**N. American Technical Support:** 800-282-9855 Toll Free USA/Canada

**EUROPE:** LDC for ON Semiconductor – European Support

**German Phone:** (+1) 303-308-7140 (Mon-Fri 2:30pm to 7:00pm CET)  
**Email:** ONlit-german@hibbertco.com  
**French Phone:** (+1) 303-308-7141 (Mon-Fri 2:00pm to 7:00pm CET)  
**Email:** ONlit-french@hibbertco.com  
**English Phone:** (+1) 303-308-7142 (Mon-Fri 12:00pm to 5:00pm GMT)  
**Email:** ONlit@hibbertco.com

**EUROPEAN TOLL-FREE ACCESS\*: 00-800-4422-3781**

\*Available from Germany, France, Italy, UK, Ireland

### **CENTRAL/SOUTH AMERICA:**

**Spanish Phone:** 303-308-7143 (Mon-Fri 8:00am to 5:00pm MST)  
**Email:** ONlit-spanish@hibbertco.com  
**Toll-Free from Mexico:** Dial 01-800-288-2872 for Access –  
then Dial 866-297-9322

**ASIA/PACIFIC:** LDC for ON Semiconductor – Asia Support

**Phone:** 303-675-2121 (Tue-Fri 9:00am to 1:00pm, Hong Kong Time)  
**Toll Free from Hong Kong & Singapore:**  
**001-800-4422-3781**  
**Email:** ONlit-asia@hibbertco.com

**JAPAN:** ON Semiconductor, Japan Customer Focus Center

4-32-1 Nishi-Gotanda, Shinagawa-ku, Tokyo, Japan 141-0031  
**Phone:** 81-3-5740-2700  
**Email:** r14525@onsemi.com

**ON Semiconductor Website:** <http://onsemi.com>

For additional information, please contact your local Sales Representative.