

SN54AHC257, SN74AHC257 QUADRUPLE 2-LINE TO 1-LINE DATA SELECTORS/MULTIPLEXERS WITH 3-STATE OUTPUTS

SCLS349C – MAY 1996 – REVISED JULY 1998

- Operating Range 2-V to 5.5-V V_{CC}
- EPIC™ (Enhanced-Performance Implanted CMOS) Process
- Package Options Include Plastic Small-Outline (D), Shrink Small-Outline (DB), Thin Very Small-Outline (DGV), Thin Shrink Small-Outline (PW), and Ceramic Flat (W) Packages, Ceramic Chip Carriers (FK), and Standard Plastic (N) and Ceramic (J) DIPs

description

These quadruple 2-line to 1-line data selectors/multiplexers are designed for 2-V to 5.5-V V_{CC} operation.

The 'AHC257 devices are designed to multiplex signals from 4-bit data sources to 4-output data lines in bus-organized systems. The 3-state outputs do not load the data lines when the output-enable (\overline{OE}) input is at a high logic level.

To ensure the high-impedance state during power up or power down, \overline{OE} should be tied to V_{CC} through a pullup resistor; the minimum value of the resistor is determined by the current-sinking capability of the driver.

The SN54AHC257 is characterized for operation over the full military temperature range of -55°C to 125°C . The SN74AHC257 is characterized for operation from -40°C to 85°C .

SN54AHC257 . . . J OR W PACKAGE
SN74AHC257 . . . D, DB, DGV, N, OR PW PACKAGE
(TOP VIEW)

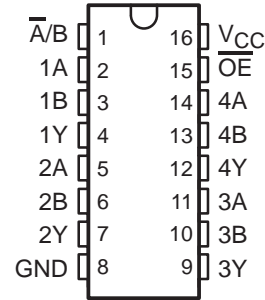

SN54AHC257 . . . FK PACKAGE
(TOP VIEW)

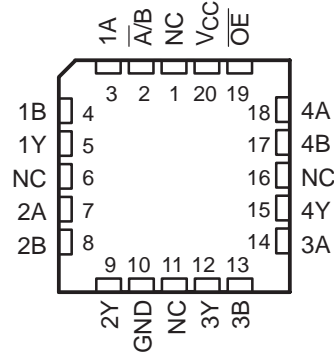

NC – No internal connection

FUNCTION TABLE

INPUTS				OUTPUT Y
\overline{OE}	$\overline{A/B}$	A	B	
H	X	X	X	Z
L	L	L	X	L
L	L	H	X	H
L	H	X	L	L
L	H	X	H	H



Please be aware that an important notice concerning availability, standard warranty, and use in critical applications of Texas Instruments semiconductor products and disclaimers thereto appears at the end of this data sheet.

EPIC is a trademark of Texas Instruments Incorporated.

PRODUCT PREVIEW information concerns products in the formative or design phase of development. Characteristic data and other specifications are design goals. Texas Instruments reserves the right to change or discontinue these products without notice.



POST OFFICE BOX 655303 • DALLAS, TEXAS 75265

Copyright © 1998, Texas Instruments Incorporated

PRODUCT PREVIEW

SN54AHC257, SN74AHC257 QUADRUPLE 2-LINE TO 1-LINE DATA SELECTORS/MULTIPLEXERS WITH 3-STATE OUTPUTS

SCLS349C – MAY 1996 – REVISED JULY 1998

logic symbol†

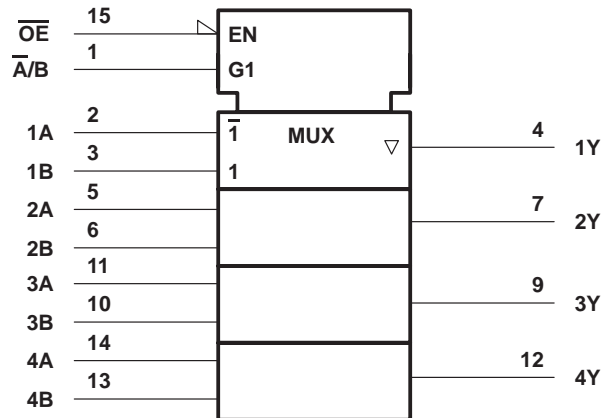

† This symbol is in accordance with ANSI/IEEE Std 91-1984 and IEC Publication 617-12. Pin numbers shown are for the D, DB, DGV, J, N, PW, and W packages.

logic diagram (positive logic)

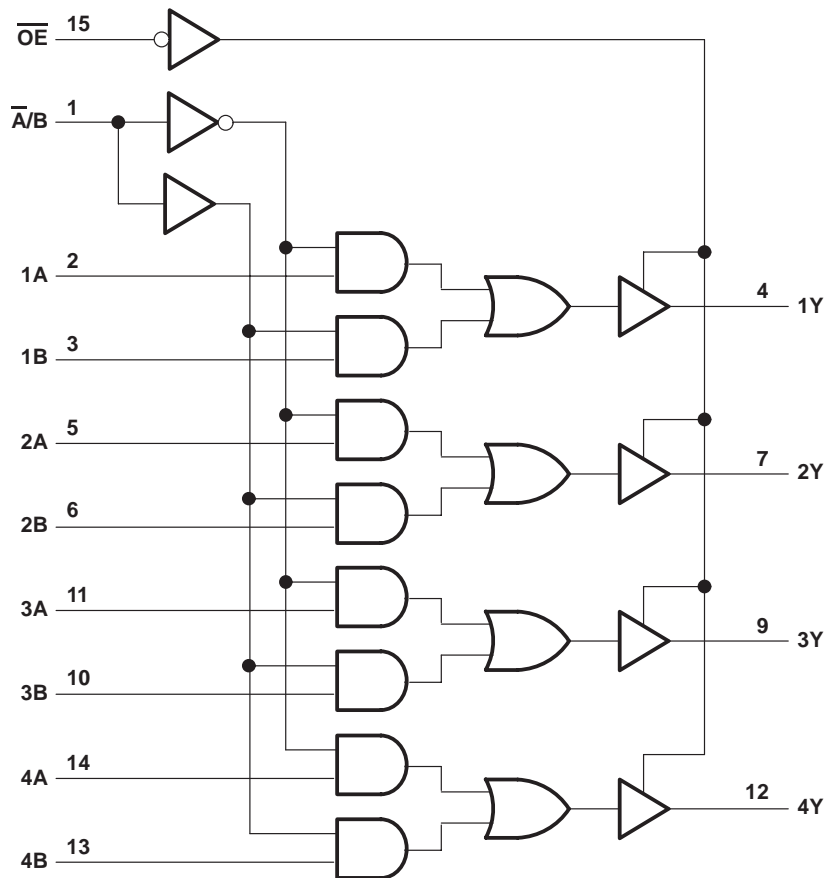

Pin numbers shown are for the D, DB, DGV, J, N, PW, and W packages.

PRODUCT PREVIEW



POST OFFICE BOX 655303 • DALLAS, TEXAS 75265

SN54AHC257, SN74AHC257
QUADRUPLE 2-LINE TO 1-LINE DATA SELECTORS/MULTIPLEXERS
WITH 3-STATE OUTPUTS

SCLS349C – MAY 1996 – REVISED JULY 1998

absolute maximum ratings over operating free-air temperature range (unless otherwise noted)†

Supply voltage range, V_{CC}	–0.5 V to 7 V
Input voltage range, V_I (see Note 1)	–0.5 V to 7 V
Output voltage range, V_O (see Note 1)	–0.5 V to $V_{CC} + 0.5$ V
Input clamp current, I_{IK} ($V_I < 0$)	–20 mA
Output clamp current, I_{OK} ($V_O < 0$ or $V_O > V_{CC}$)	±20 mA
Continuous output current, I_O ($V_O = 0$ to V_{CC})	±25 mA
Continuous current through V_{CC} or GND	±50 mA
Package thermal impedance, θ_{JA} (see Note 2): D package	113°C/W
DB package	131°C/W
DGV package	180°C/W
N package	78°C/W
PW package	149°C/W
Storage temperature range, T_{stg}	–65°C to 150°C

† Stresses beyond those listed under “absolute maximum ratings” may cause permanent damage to the device. These are stress ratings only, and functional operation of the device at these or any other conditions beyond those indicated under “recommended operating conditions” is not implied. Exposure to absolute-maximum-rated conditions for extended periods may affect device reliability.

- NOTES: 1. The input and output voltage ratings may be exceeded if the input and output current ratings are observed.
 2. The package thermal impedance is calculated in accordance with JESD 51, except for through-hole packages, which use a trace length of zero.

recommended operating conditions (see Note 3)

		SN54AHC257		SN74AHC257		UNIT
		MIN	MAX	MIN	MAX	
V_{CC}	Supply voltage	2	5.5	2	5.5	V
V_{IH}	High-level input voltage	$V_{CC} = 2$ V		1.5		V
		$V_{CC} = 3$ V		2.1		
		$V_{CC} = 5.5$ V		3.85		
V_{IL}	Low-level input voltage	$V_{CC} = 2$ V		0.5		V
		$V_{CC} = 3$ V		0.9		
		$V_{CC} = 5.5$ V		1.65		
V_I	Input voltage	0	5.5	0	5.5	V
V_O	Output voltage	0	V_{CC}	0	V_{CC}	V
I_{OH}	High-level output current	$V_{CC} = 2$ V		–50		μ A
		$V_{CC} = 3.3$ V ± 0.3 V		–4		
		$V_{CC} = 5$ V ± 0.5 V		–8		
I_{OL}	Low-level output current	$V_{CC} = 2$ V		50		μ A
		$V_{CC} = 3.3$ V ± 0.3 V		4		
		$V_{CC} = 5$ V ± 0.5 V		8		
$\Delta t/\Delta v$	Input transition rise or fall rate	$V_{CC} = 3.3$ V ± 0.3 V		100		ns/V
		$V_{CC} = 5$ V ± 0.5 V		20		
T_A	Operating free-air temperature	–55	125	–40	85	°C

NOTE 3: All unused inputs of the device must be held at V_{CC} or GND to ensure proper device operation. Refer to the TI application report, *Implications of Slow or Floating CMOS Inputs*, literature number SCBA004.

PRODUCT PREVIEW



SN54AHC257, SN74AHC257
QUADRUPLE 2-LINE TO 1-LINE DATA SELECTORS/MULTIPLEXERS
WITH 3-STATE OUTPUTS

SCLS349C – MAY 1996 – REVISED JULY 1998

electrical characteristics over recommended operating free-air temperature range (unless otherwise noted)

PARAMETER	TEST CONDITIONS	V _{CC}	T _A = 25°C			SN54AHC257		SN74AHC257		UNIT
			MIN	TYP	MAX	MIN	MAX	MIN	MAX	
V _{OH}	I _{OH} = -50 μA	2 V	1.9	2		1.9		1.9	V	
		3 V	2.9	3		2.9		2.9		
		4.5 V	4.4	4.5		4.4		4.4		
	I _{OH} = -4 mA	3 V	2.58			2.48		2.48		
	I _{OH} = -8 mA	4.5 V	3.94			3.8		3.8		
V _{OL}	I _{OL} = 50 μA	2 V			0.1		0.1	0.1	V	
		3 V			0.1		0.1	0.1		
		4.5 V			0.1		0.1	0.1		
	I _{OL} = 4 mA	3 V			0.36		0.5	0.44		
	I _{OL} = 8 mA	4.5 V			0.36		0.5	0.44		
I _I	V _I = V _{CC} or GND	5.5 V			±0.1		±1	±1	μA	
I _{CC}	V _I = V _{CC} or GND, I _O = 0	5.5 V			4		40	40	μA	
I _{OZ}	V _O = V _{CC} or GND	5.5 V			±0.25		±2.5	±2.5	μA	
C _i	V _I = V _{CC} or GND	5 V							pF	

PRODUCT PREVIEW



SN54AHC257, SN74AHC257
**QUADRUPLE 2-LINE TO 1-LINE DATA SELECTORS/MULTIPLEXERS
 WITH 3-STATE OUTPUTS**

SCLS349C – MAY 1996 – REVISED JULY 1998

switching characteristics over recommended operating free-air temperature range,
 $V_{CC} = 3.3\text{ V} \pm 0.3\text{ V}$ (unless otherwise noted) (see Figure 1)

PARAMETER	FROM (INPUT)	TO (OUTPUT)	LOAD CAPACITANCE	SN54AHC257				UNIT	
				$T_A = 25^\circ\text{C}$			MIN		MAX
				MIN	TYP	MAX			
t_{PLH}^*	A or B	Y	$C_L = 15\text{ pF}$				ns		
t_{PHL}^*									
t_{PLH}^*	\bar{A}/B	Y	$C_L = 15\text{ pF}$				ns		
t_{PHL}^*									
t_{PZH}^*	\overline{OE}	Y	$C_L = 15\text{ pF}$				ns		
t_{PZL}^*									
t_{PHZ}^*	\overline{OE}	Y	$C_L = 15\text{ pF}$				ns		
t_{PLZ}^*									
t_{PLH}	A or B	Y	$C_L = 50\text{ pF}$				ns		
t_{PHL}									
t_{PLH}	\bar{A}/B	Y	$C_L = 50\text{ pF}$				ns		
t_{PHL}									
t_{PZH}	\overline{OE}	Y	$C_L = 50\text{ pF}$				ns		
t_{PZL}									
t_{PHZ}	\overline{OE}	Y	$C_L = 50\text{ pF}$				ns		
t_{PLZ}									

* On products compliant to MIL-PRF-38535, this parameter is not production tested.

switching characteristics over recommended operating free-air temperature range,
 $V_{CC} = 3.3\text{ V} \pm 0.3\text{ V}$ (unless otherwise noted) (see Figure 1)

PARAMETER	FROM (INPUT)	TO (OUTPUT)	LOAD CAPACITANCE	SN74AHC257				UNIT	
				$T_A = 25^\circ\text{C}$			MIN		MAX
				MIN	TYP	MAX			
t_{PLH}	A or B	Y	$C_L = 15\text{ pF}$				ns		
t_{PHL}									
t_{PLH}	\bar{A}/B	Y	$C_L = 15\text{ pF}$				ns		
t_{PHL}									
t_{PZH}	\overline{OE}	Y	$C_L = 15\text{ pF}$				ns		
t_{PZL}									
t_{PHZ}	\overline{OE}	Y	$C_L = 15\text{ pF}$				ns		
t_{PLZ}									
t_{PLH}	A or B	Y	$C_L = 50\text{ pF}$				ns		
t_{PHL}									
t_{PLH}	\bar{A}/B	Y	$C_L = 50\text{ pF}$				ns		
t_{PHL}									
t_{PZH}	\overline{OE}	Y	$C_L = 50\text{ pF}$				ns		
t_{PZL}									
t_{PHZ}	\overline{OE}	Y	$C_L = 50\text{ pF}$				ns		
t_{PLZ}									

PRODUCT PREVIEW



SN54AHC257, SN74AHC257
QUADRUPLE 2-LINE TO 1-LINE DATA SELECTORS/MULTIPLEXERS
WITH 3-STATE OUTPUTS

SCLS349C – MAY 1996 – REVISED JULY 1998

switching characteristics over recommended operating free-air temperature range,
 $V_{CC} = 5\text{ V} \pm 0.5\text{ V}$ (unless otherwise noted) (see Figure 1)

PARAMETER	FROM (INPUT)	TO (OUTPUT)	LOAD CAPACITANCE	SN54AHC257					UNIT
				$T_A = 25^\circ\text{C}$			MIN	MAX	
				MIN	TYP	MAX			
t_{PLH}^*	A or B	Y	$C_L = 15\text{ pF}$					ns	
t_{PHL}^*									
t_{PLH}^*	\bar{A}/B	Y	$C_L = 15\text{ pF}$					ns	
t_{PHL}^*									
t_{PZH}^*	\overline{OE}	Y	$C_L = 15\text{ pF}$					ns	
t_{PZL}^*									
t_{PHZ}^*	\overline{OE}	Y	$C_L = 15\text{ pF}$					ns	
t_{PLZ}^*									
t_{PLH}	A or B	Y	$C_L = 50\text{ pF}$					ns	
t_{PHL}									
t_{PLH}	\bar{A}/B	Y	$C_L = 50\text{ pF}$					ns	
t_{PHL}									
t_{PZH}	\overline{OE}	Y	$C_L = 50\text{ pF}$					ns	
t_{PZL}									
t_{PHZ}	\overline{OE}	Y	$C_L = 50\text{ pF}$					ns	
t_{PLZ}									

* On products compliant to MIL-PRF-38535, this parameter is not production tested.

switching characteristics over recommended operating free-air temperature range,
 $V_{CC} = 5\text{ V} \pm 0.5\text{ V}$ (unless otherwise noted) (see Figure 1)

PARAMETER	FROM (INPUT)	TO (OUTPUT)	LOAD CAPACITANCE	SN74AHC257					UNIT
				$T_A = 25^\circ\text{C}$			MIN	MAX	
				MIN	TYP	MAX			
t_{PLH}	A or B	Y	$C_L = 15\text{ pF}$					ns	
t_{PHL}									
t_{PLH}	\bar{A}/B	Y	$C_L = 15\text{ pF}$					ns	
t_{PHL}									
t_{PZH}	\overline{OE}	Y	$C_L = 15\text{ pF}$					ns	
t_{PZL}									
t_{PHZ}	\overline{OE}	Y	$C_L = 15\text{ pF}$					ns	
t_{PLZ}									
t_{PLH}	A or B	Y	$C_L = 50\text{ pF}$					ns	
t_{PHL}									
t_{PLH}	\bar{A}/B	Y	$C_L = 50\text{ pF}$					ns	
t_{PHL}									
t_{PZH}	\overline{OE}	Y	$C_L = 50\text{ pF}$					ns	
t_{PZL}									
t_{PHZ}	\overline{OE}	Y	$C_L = 50\text{ pF}$					ns	
t_{PLZ}									

PRODUCT PREVIEW



SN54AHC257, SN74AHC257
**QUADRUPLE 2-LINE TO 1-LINE DATA SELECTORS/MULTIPLEXERS
 WITH 3-STATE OUTPUTS**

SCLS349C – MAY 1996 – REVISED JULY 1998

noise characteristics $V_{CC} = 5\text{ V}$, $C_L = 50\text{ pF}$, $T_A = 25^\circ\text{C}$ (see Note 4)

PARAMETER	SN74AHC257			UNIT
	MIN	TYP	MAX	
$V_{OL(P)}$ Quiet output, maximum dynamic V_{OL}				V
$V_{OL(V)}$ Quiet output, minimum dynamic V_{OL}				V
$V_{OH(V)}$ Quiet output, minimum dynamic V_{OH}				V
$V_{IH(D)}$ High-level dynamic input voltage				V
$V_{IL(D)}$ Low-level dynamic input voltage				V

NOTE 4: Characteristics are for surface-mount packages only.

operating characteristics, $V_{CC} = 5\text{ V}$, $T_A = 25^\circ\text{C}$

PARAMETER	TEST CONDITIONS	TYP	UNIT
C_{pd} Power dissipation capacitance	No load, $f = 1\text{ MHz}$		pF

PRODUCT PREVIEW



SN54AHC257, SN74AHC257 QUADRUPLE 2-LINE TO 1-LINE DATA SELECTORS/MULTIPLEXERS WITH 3-STATE OUTPUTS

SCLS349C – MAY 1996 – REVISED JULY 1998

PARAMETER MEASUREMENT INFORMATION

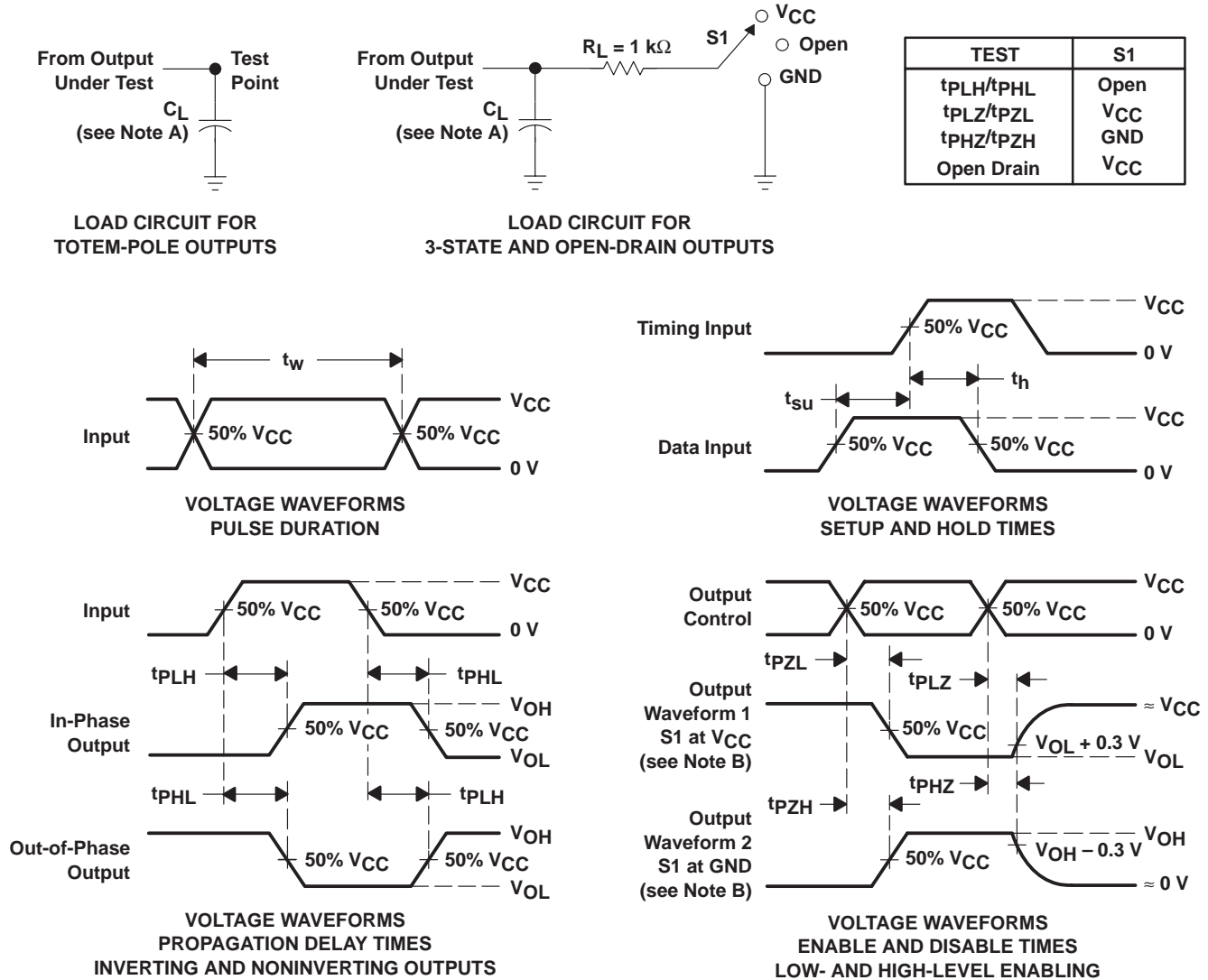

- NOTES:
- C_L includes probe and jig capacitance.
 - Waveform 1 is for an output with internal conditions such that the output is low except when disabled by the output control. Waveform 2 is for an output with internal conditions such that the output is high except when disabled by the output control.
 - All input pulses are supplied by generators having the following characteristics: $PRR \leq 1\text{ MHz}$, $Z_O = 50\ \Omega$, $t_r \leq 3\text{ ns}$, $t_f \leq 3\text{ ns}$.
 - The outputs are measured one at a time with one input transition per measurement.

Figure 1. Load Circuit and Voltage Waveforms

PRODUCT PREVIEW

IMPORTANT NOTICE

Texas Instruments and its subsidiaries (TI) reserve the right to make changes to their products or to discontinue any product or service without notice, and advise customers to obtain the latest version of relevant information to verify, before placing orders, that information being relied on is current and complete. All products are sold subject to the terms and conditions of sale supplied at the time of order acknowledgement, including those pertaining to warranty, patent infringement, and limitation of liability.

TI warrants performance of its semiconductor products to the specifications applicable at the time of sale in accordance with TI's standard warranty. Testing and other quality control techniques are utilized to the extent TI deems necessary to support this warranty. Specific testing of all parameters of each device is not necessarily performed, except those mandated by government requirements.

CERTAIN APPLICATIONS USING SEMICONDUCTOR PRODUCTS MAY INVOLVE POTENTIAL RISKS OF DEATH, PERSONAL INJURY, OR SEVERE PROPERTY OR ENVIRONMENTAL DAMAGE ("CRITICAL APPLICATIONS"). TI SEMICONDUCTOR PRODUCTS ARE NOT DESIGNED, AUTHORIZED, OR WARRANTED TO BE SUITABLE FOR USE IN LIFE-SUPPORT DEVICES OR SYSTEMS OR OTHER CRITICAL APPLICATIONS. INCLUSION OF TI PRODUCTS IN SUCH APPLICATIONS IS UNDERSTOOD TO BE FULLY AT THE CUSTOMER'S RISK.

In order to minimize risks associated with the customer's applications, adequate design and operating safeguards must be provided by the customer to minimize inherent or procedural hazards.

TI assumes no liability for applications assistance or customer product design. TI does not warrant or represent that any license, either express or implied, is granted under any patent right, copyright, mask work right, or other intellectual property right of TI covering or relating to any combination, machine, or process in which such semiconductor products or services might be or are used. TI's publication of information regarding any third party's products or services does not constitute TI's approval, warranty or endorsement thereof.