



QUAD 2-INPUT AND GATE

- HIGH SPEED: $t_{PD} = 5 \text{ ns}$ (TYP.) at $V_{CC} = 3.3\text{V}$
- COMPATIBLE WITH TTL OUTPUTS
- LOW POWER DISSIPATION:
 $I_{CC} = 2 \mu\text{A}$ (MAX.) at $T_A = 25^\circ\text{C}$
- LOW NOISE:
 $V_{OLP} = 0.3 \text{ V}$ (TYP.) at $V_{CC} = 3.3\text{V}$
- 75Ω TRANSMISSION LINE DRIVING CAPABILITY
- SYMMETRICAL OUTPUT IMPEDANCE:
 $|I_{OH}| = I_{OL} = 24 \text{ mA}$ (MIN)
- PCI BUS LEVELS GUARANTEED AT 24mA
- BALANCED PROPAGATION DELAYS:
 $t_{PLH} \cong t_{PHL}$
- OPERATING VOLTAGE RANGE:
 V_{CC} (OPR) = 2V to 3.6V (1.2V Data Retention)
- PIN AND FUNCTION COMPATIBLE WITH 74 SERIES 08
- IMPROVED LATCH-UP IMMUNITY

DESCRIPTION

The LVQ08 is a low voltage CMOS QUAD 2-INPUT AND GATE fabricated with sub-micron silicon gate and double-layer metal wiring C²MOS

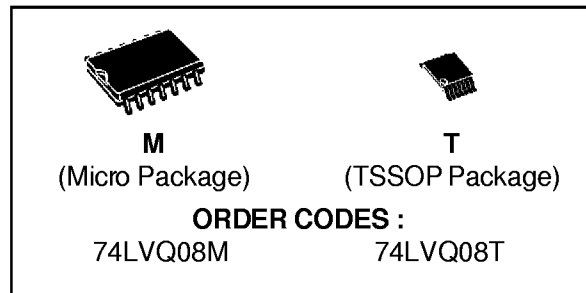

technology. It is ideal for low power and low noise 3.3V applications.

The internal circuit is composed of 2 stages including buffer output, which enables high noise immunity and stable output.

It has better speed performance at 3.3V than 5V LS-TTL family combined with the true CMOS low power consumption.

All inputs and outputs are equipped with protection circuits against static discharge, giving them 2KV ESD immunity and transient excess voltage.

PIN CONNECTION AND IEC LOGIC SYMBOLS

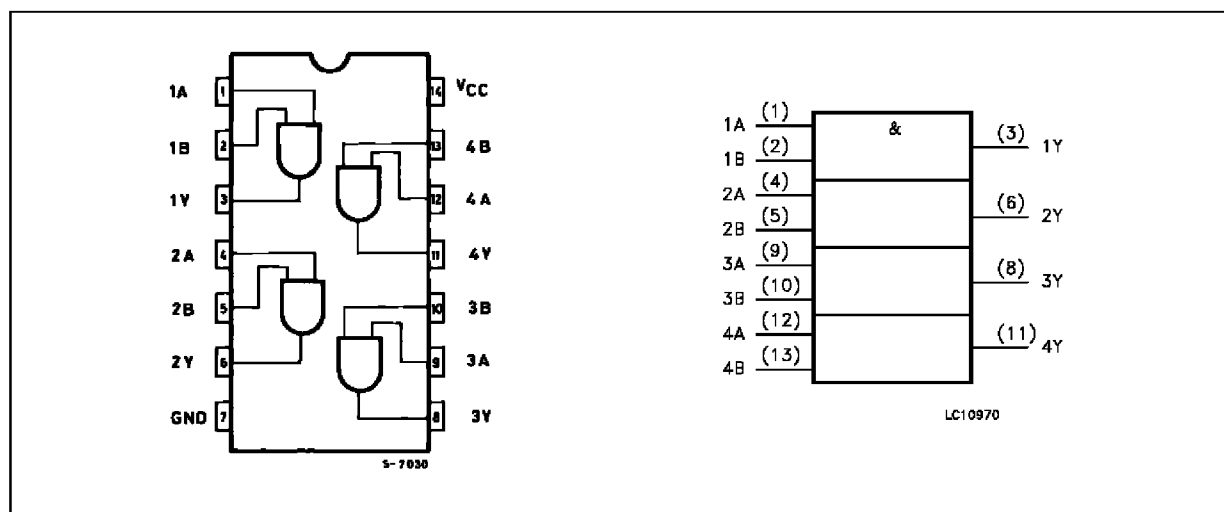

INPUT AND OUTPUT EQUIVALENT CIRCUIT

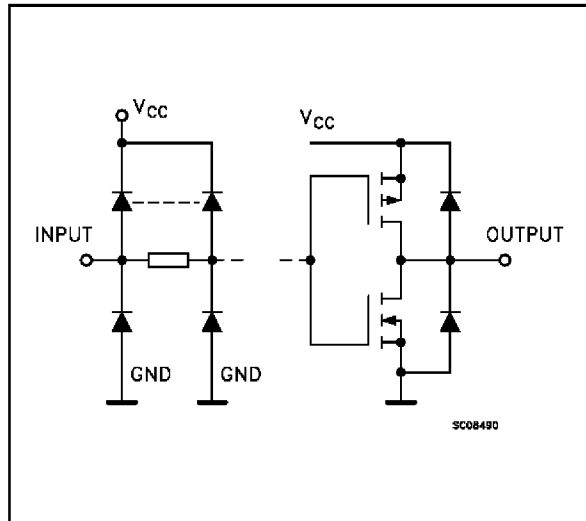

PIN DESCRIPTION

PIN No	SYMBOL	NAME AND FUNCTION
1, 4, 9, 12	1A to 4A	Data Inputs
2, 5, 10, 13	1B to 4B	Data Inputs
3, 6, 8, 11	1Y to 4Y	Data Outputs
7	GND	Ground (0V)
14	V _{CC}	Positive Supply Voltage

TRUTH TABLE

A	B	Y
L	L	L
L	H	L
H	L	L
H	H	H

ABSOLUTE MAXIMUM RATINGS

Symbol	Parameter	Value	Unit
V _{CC}	Supply Voltage	-0.5 to +7	V
V _I	DC Input Voltage	-0.5 to V _{CC} + 0.5	V
V _O	DC Output Voltage	-0.5 to V _{CC} + 0.5	V
I _{IK}	DC Input Diode Current	± 20	mA
I _{OK}	DC Output Diode Current	± 20	mA
I _O	DC Output Current	± 50	mA
I _{CC} or I _{GND}	DC V _{CC} or Ground Current	± 200	mA
T _{stg}	Storage Temperature	-65 to +150	°C
T _L	Lead Temperature (10 sec)	300	°C

Absolute Maximum Ratings are those values beyond which damage to the device may occur. Functional operation under these condition is not implied.

RECOMMENDED OPERATING CONDITIONS

Symbol	Parameter	Value	Unit
V _{CC}	Supply Voltage (note 1)	2 to 3.6	V
V _I	Input Voltage	0 to V _{CC}	V
V _O	Output Voltage	0 to V _{CC}	V
T _{op}	Operating Temperature:	-40 to +85	°C
dt/dv	Input Rise and Fall Time (V _{CC} = 3V) (note 2)	0 to 10	ns/V

1) Truth Table guaranteed: 1.2V to 3.6V

2) V_{IN} from 0.8V to 2V

DC SPECIFICATIONS

Symbol	Parameter	Test Conditions		Value					Unit	
				V _{CC} (V)	T _A = 25 °C			-40 to 85 °C		
					Min.	Typ.	Max.	Min.		Max.
V _{IH}	High Level Input Voltage	3.0 to 3.6		2.0			2.0		V	
V _{IL}	Low Level Input Voltage					0.8		0.8		V
V _{OH}	High Level Output Voltage	3.0	V _I ^(*) = V _{IH}	I _O = -50 μA	2.9	2.99		2.9		V
				I _O = -12 mA	2.58			2.48		
				I _O = -24 mA				2.2		
V _{OL}	Low Level Output Voltage	3.0	V _I ^(*) = V _{IH} or V _{IL}	I _O = 50 μA		0.002	0.1		0.1	V
				I _O = 12 mA		0	0.36		0.44	
				I _O = 24 mA					0.55	
I _I	Input Leakage Current	3.6	V _I = V _{CC} or GND			±0.1		±1	μA	
I _{CC}	Quiescent Supply Current	3.6	V _I = V _{CC} or GND			2		20	μA	
I _{OLD}	Dynamic Output Current (note 1, 2)	3.6	V _{OLD} = 0.8 V max				36		mA	
I _{OHD}			V _{OHD} = 2 V min				-25		mA	

1) Maximum test duration 2ms, one output loaded at time

2) Incident wave switching is guaranteed on transmission lines with impedances as low as 50 Ω.

(*) All outputs loaded.

DYNAMIC SWITCHING CHARACTERISTICS

Symbol	Parameter	Test Conditions		Value					Unit	
				V _{CC} (V)	T _A = 25 °C			-40 to 85 °C		
					Min.	Typ.	Max.	Min.		Max.
V _{OLP}	Dynamic Low Voltage	3.3	C _L = 50 pF		0.3	0.8			V	
V _{OLV}	Quiet Output (note 1, 2)			-0.8	-0.3					
V _{IHD}	Dynamic High Voltage Input (note 1, 3)	3.3				2				
V _{ILD}	Dynamic Low Voltage Input (note 1, 3)	3.3		0.8						

1) Worst case package.

2) Max number of outputs defined as (n). Data inputs are driven 0V to 3.3V, (n-1) outputs switching and one output at GND.

3) Max number of data inputs (n) switching. (n-1) switching 0V to 3.3V. Inputs under test switching: 3.3V to threshold (V_{ILD}), 0V to threshold (V_{IHD}), f=1MHz.

AC ELECTRICAL CHARACTERISTICS ($C_L = 50 \text{ pF}$, $R_L = 500 \Omega$, Input $t_r = t_f = 3 \text{ ns}$)

Symbol	Parameter	Test Condition		Value					Unit
				T _A = 25 °C			-40 to 85 °C		
				V _{CC} (V)	Min.	Typ.	Max.	Min.	
t _{PLH} t _{PHL}	Propagation Delay Time	2.7		6.0	12.0		13.0	ns	
		3.3 ^(*)		5.0	8.5		9.0		
t _{OSLH} t _{OSHL}	Output to Output Skew Time (note 1, 2)	2.7		0.5	1.5		1.5	ns	
		3.3 ^(*)		0.5	1.5		1.5		

1) Skew is defined as the absolute value of the difference between the actual propagation delay for any two outputs of the same device switching in the same direction, either HIGH or LOW ($t_{OSLH} = |t_{PLHn} - t_{PLHn}|$, $t_{OSHL} = |t_{PHLn} - t_{PHLn}|$)

2) Parameter guaranteed by design

(*) Voltage range is $3.3V \pm 0.3V$

CAPACITIVE CHARACTERISTICS

Symbol	Parameter	Test Conditions		Value					Unit
				T _A = 25 °C			-40 to 85 °C		
				V _{CC} (V)	Min.	Typ.	Max.	Min.	
C _{IN}	Input Capacitance	3.3		4				pF	
C _{PD}	Power Dissipation Capacitance (note 1)	3.3	f _{IN} = 10 MHz	22				pF	

1) C_{PD} is defined as the value of the IC's internal equivalent capacitance which is calculated from the operating current consumption without load. (Refer to Test Circuit). Average operating current can be obtained by the following equation. $I_{CC(opr)} = C_{PD} \cdot V_{CC} \cdot f_{IN} + I_{CC}/4$ (per gate)

TEST CIRCUIT

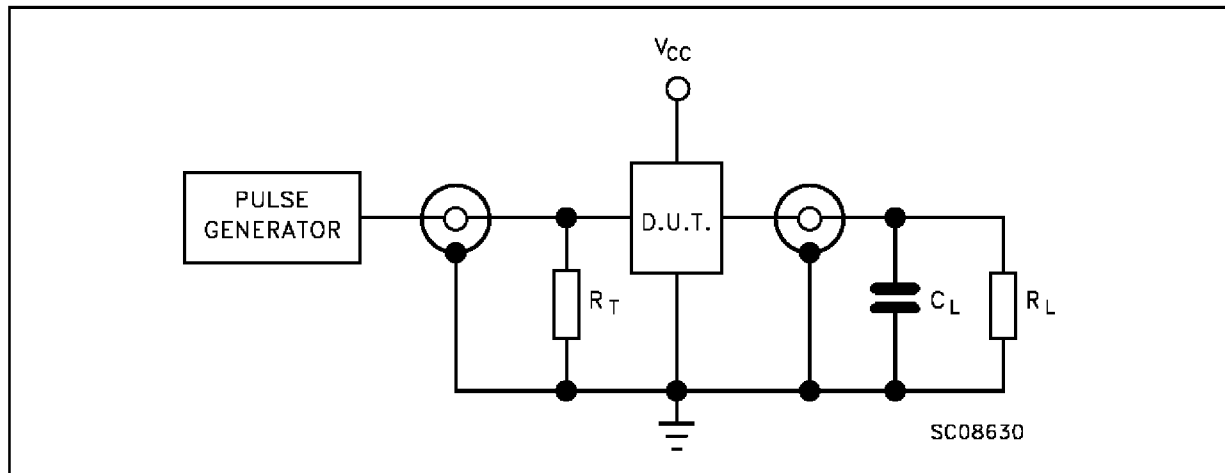

$C_L = 50$ pF or equivalent (includes jig and probe capacitance)

$R_L = R_T = 500\Omega$ or equivalent

$R_T = Z_{OUT}$ of pulse generator (typically 50Ω)

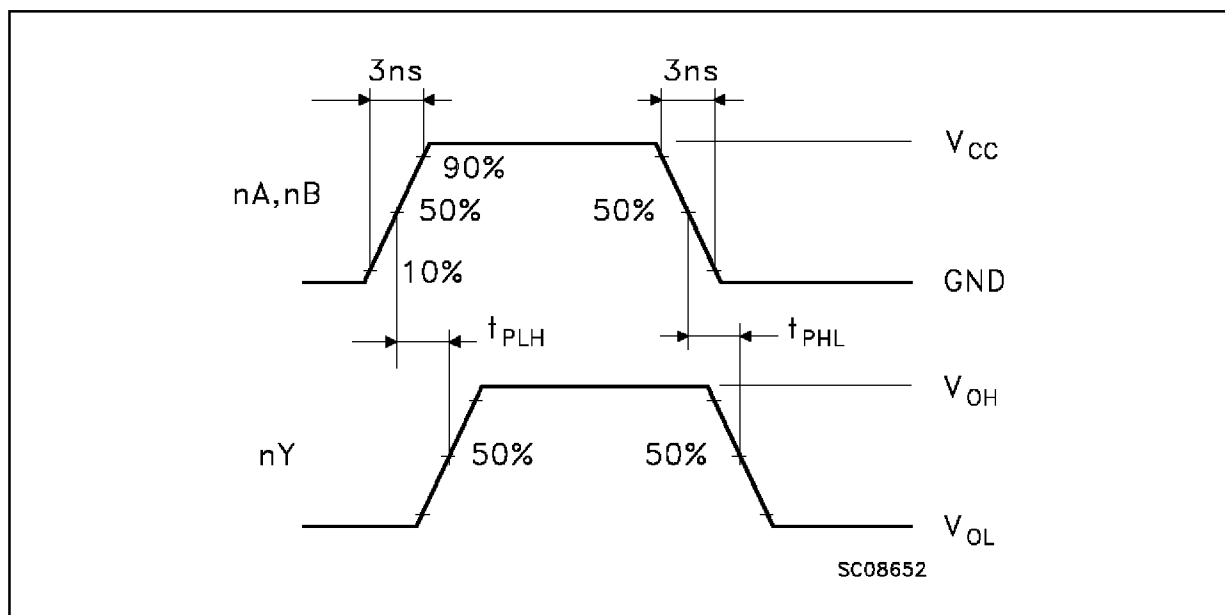
WAVEFORM: PROPAGATION DELAYS ($f=1$ MHz; 50% duty cycle)

SO-14 MECHANICAL DATA

DIM.	mm			inch		
	MIN.	TYP.	MAX.	MIN.	TYP.	MAX.
A			1.75			0.068
a1	0.1		0.2	0.003		0.007
a2			1.65			0.064
b	0.35		0.46	0.013		0.018
b1	0.19		0.25	0.007		0.010
C		0.5			0.019	
c1	45 (typ.)					
D	8.55		8.75	0.336		0.344
E	5.8		6.2	0.228		0.244
e		1.27			0.050	
e3		7.62			0.300	
F	3.8		4.0	0.149		0.157
G	4.6		5.3	0.181		0.208
L	0.5		1.27	0.019		0.050
M			0.68			0.026
S	8 (max.)					

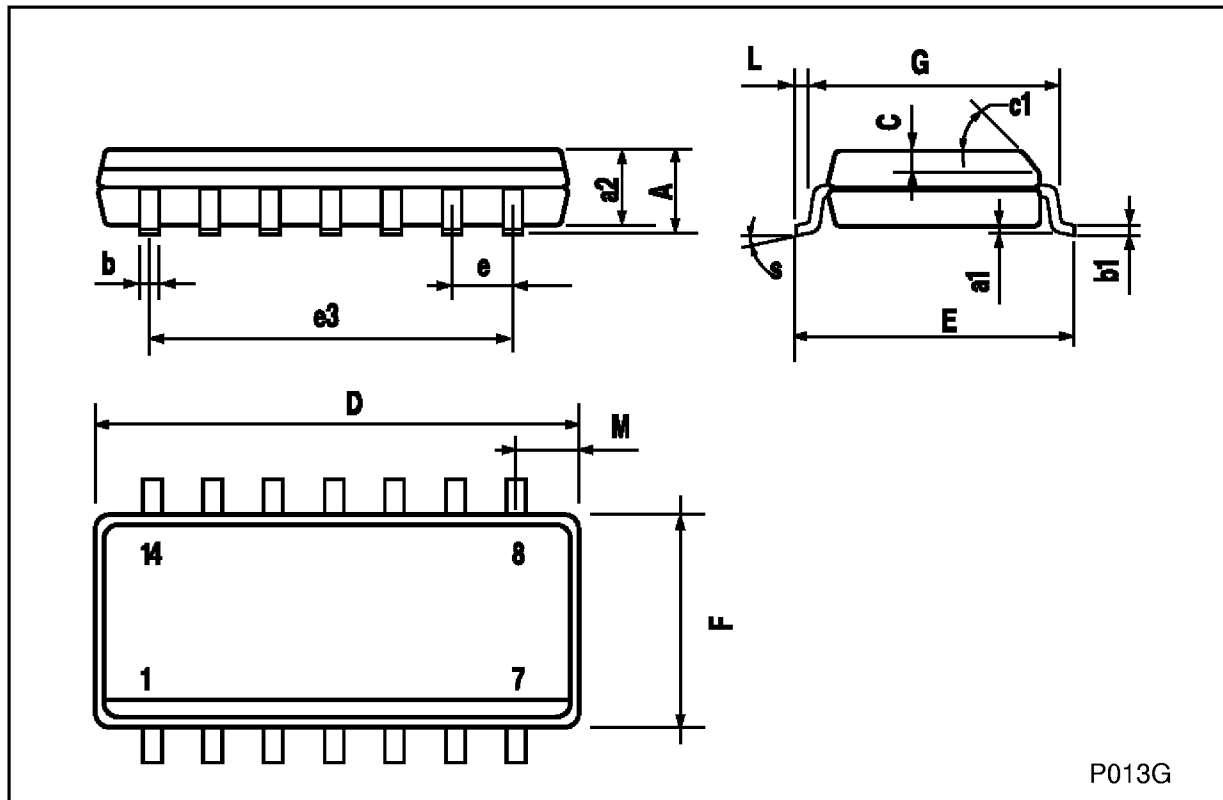

P013G

TSSOP14 MECHANICAL DATA

DIM.	mm			inch		
	MIN.	TYP.	MAX.	MIN.	TYP.	MAX.
A			1.1			0.433
A1	0.05	0.10	0.15	0.002	0.004	0.006
A2	0.85	0.9	0.95	0.335	0.354	0.374
b	0.19		0.30	0.0075		0.0118
c	0.09		0.20	0.0035		0.0079
D	4.9	5	5.1	0.193	0.197	0.201
E	6.25	6.4	6.5	0.246	0.252	0.256
E1	4.3	4.4	4.48	0.169	0.173	0.176
e		0.65 BSC			0.0256 BSC	
K	0°	4°	8°	0°	4°	8°
L	0.50	0.60	0.70	0.020	0.024	0.028

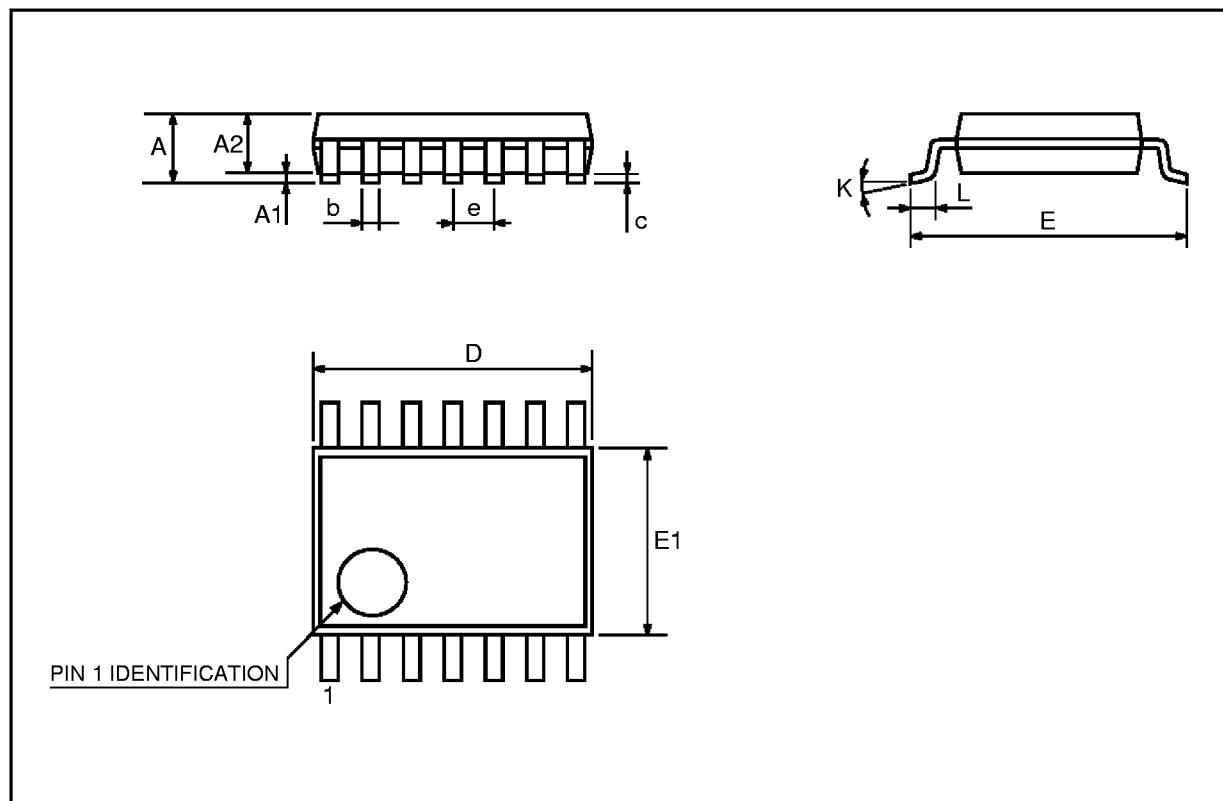

Information furnished is believed to be accurate and reliable. However, STMicroelectronics assumes no responsibility for the consequences of use of such information nor for any infringement of patents or other rights of third parties which may result from its use. No license is granted by implication or otherwise under any patent or patent rights of STMicroelectronics. Specification mentioned in this publication are subject to change without notice. This publication supersedes and replaces all information previously supplied. STMicroelectronics products are not authorized for use as critical components in life support devices or systems without express written approval of STMicroelectronics.

The ST logo is a trademark of STMicroelectronics

© 1999 STMicroelectronics – Printed in Italy – All Rights Reserved

STMicroelectronics GROUP OF COMPANIES

Australia - Brazil - Canada - China - France - Germany - Italy - Japan - Korea - Malaysia - Malta - Mexico - Morocco - The Netherlands - Singapore - Spain - Sweden - Switzerland - Taiwan - Thailand - United Kingdom - U.S.A.

<http://www.st.com>