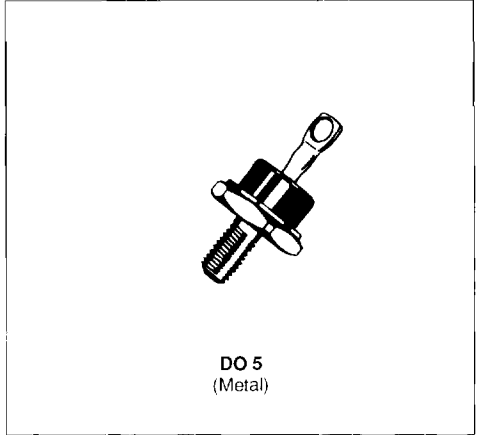

FAST RECOVERY RECTIFIER DIODES

- VERY FAST RECOVERY TIME
- VERY LOW FORWARD RECOVERY TIME
- VERY LOW RECOVERED CHARGE

APPLICATIONS

- DC AND AC MOTOR CONTROL
- SWITCHMODE POWER SUPPLY
- HIGH FREQUENCY CHOPPERS

ABSOLUTE RATINGS (limiting values)

| Symbol | Parameter | | Value | Unit |
|----------------|--|----------------------------|-------------|------|
| I_{FRM} | Repetitive Peak Forward Current | $t_p \leq 20\mu s$ | 250 | A |
| $I_{F(AV)}$ | Average Forward Current | $T_C = 100^\circ C$ | 30 | A |
| I_{FSM} | Surge non Repetitive Forward Current | $t_p = 10ms$ Sinusoidal | 300 | A |
| P_{TOT} | Power Dissipation | $T_C = 100^\circ C$ | 50 | W |
| T_{stg} T | Storage and Junction Temperature Range | | - 65 to 150 | C |

| Symbol | Parameter | BYX 65- | | | | | Unit |
|-----------|---------------------------------|---------|-----|-----|-----|-----|------|
| | | 50 | 100 | 200 | 300 | 400 | |
| V_{RRM} | Repetitive Peak Reverse Voltage | 50 | 100 | 200 | 300 | 400 | V |

THERMAL RESISTANCE

| Symbol | Parameter | Value | Unit |
|---------------|---------------|-------|--------------|
| $R_{th(j-c)}$ | Junction-case | 1 | $^\circ C/W$ |

ELECTRICAL CHARACTERISTICS

STATIC CHARACTERISTICS

| Symbol | Test Conditions | Test Conditions | Min. | Typ. | Max. | Unit |
|--------|-------------------------|--------------------|------|------|------|------|
| I_R | $T = 100^\circ\text{C}$ | $V_R = V_{RRM}$ | | | 10 | mA |
| V_F | $T = 25^\circ\text{C}$ | $I_f = 30\text{A}$ | | | 1.5 | V |

RECOVERY CHARACTERISTICS

| Symbol | Test Conditions | Test Conditions | Min. | Typ. | Max. | Unit |
|----------|--|--|------|------|-------|---------------|
| t_{rr} | $T = 25^\circ\text{C}$ $V_a = 30\text{V}$ | $I_f = 1\text{A}$ $di_f/dt = -15\text{A}/\mu\text{s}$ | | | 100 | ns |
| Q_{rr} | $T = 25^\circ\text{C}$ $V_a = 30\text{V}$ | $I_f = 1\text{A}$ $di_f/dt = -15\text{A}/\mu\text{s}$ | | | 0.075 | μC |
| I_{RM} | $T = 25^\circ\text{C}$ $V_a = 30\text{V}$ | $I_f = 1\text{A}$ $di_f/dt = -15\text{A}/\mu\text{s}$ | | | 1.5 | A |

To evaluate the conduction losses use the following equations :

$$V_F = 1.15 + 0.008 I_F \quad P = 1.15 \times I_{F(AV)} + 0.008 I_F^2 (RMS)$$

PACKAGE MECHANICAL DATA

DO 5 Metal

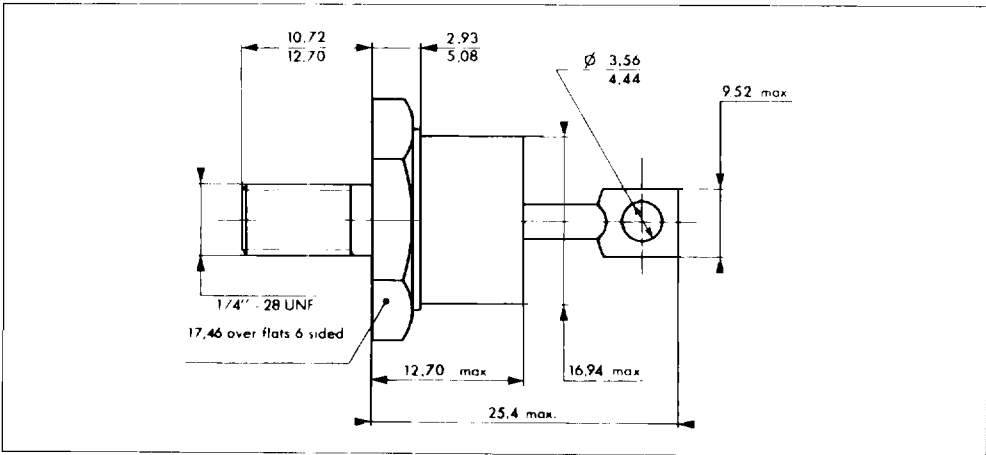

Cooling method : by conduction (method C)

Marking : Cathode connected to case - type number

Anode connected to case - type number + suffix R (consult us for these reverse version datasheets)

Weight : 18.84g

Recommended torque value : 250cm. N

Maximum torque value : 310cm. N