

SN74ALVC16952 16-BIT REGISTERED TRANSCIVER WITH 3-STATE OUTPUTS

SCAS277 - JANUARY 1993 - REVISED MARCH 1994

- Member of the Texas Instruments *Widebus™* Family
- *EPIC™* (Enhanced-Performance Implanted CMOS) Submicron Process
- Designed to Facilitate Incident-Wave Switching for Line Impedances of 50 Ω or Greater
- Typical V_{OLP} (Output Ground Bounce) < 0.8 V at $V_{CC} = 3.3$ V, $T_A = 25^\circ\text{C}$
- Typical V_{OHV} (Output V_{OH} Undershoot) > 2 V at $V_{CC} = 3.3$ V, $T_A = 25^\circ\text{C}$
- Bus-Hold On Data Inputs Eliminates the Need for External Pullup/Pulldown Resistors
- Package Options Include Plastic 300-mil Shrink Small-Outline (DL) and Thin Shrink Small-Outline (DGG) Packages

description

This 16-bit registered transceiver is designed for 2.7-V to 3.6-V V_{CC} operation.

The SN74ALVC16952 contains two sets of D-type flip-flops for temporary storage of data flowing in either direction. It can be used as two 8-bit transceivers or one 16-bit transceiver. Data on the A or B bus is stored in the registers on the low-to-high transition of the clock (CLKAB or CLKBA) input provided that the clock-enable ($\overline{\text{CEAB}}$ or $\overline{\text{CEBA}}$) input is low. Taking the output-enable ($\overline{\text{OEAB}}$ or $\overline{\text{OEBA}}$) input low accesses the data on either port.

The SN74ALVC16952 is available in TI's shrink small-outline (DL) and thin shrink small-outline (DGG) packages, which provide twice the I/O pin count and functionality of standard small-outline packages in the same printed-circuit-board area.

The SN74ALVC16952 is characterized for operation from -40°C to 85°C .

DGG OR DL PACKAGE
(TOP VIEW)

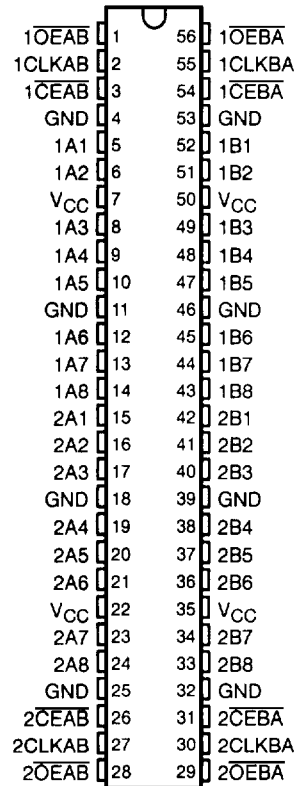

FUNCTION TABLE†

INPUTS				OUTPUT B
$\overline{\text{CLKENAB}}$	CLKAB	$\overline{\text{OEAB}}$	A	
H	X	L	X	B_0^\ddagger
X	L	L	X	B_0^\ddagger
L	↑	L	L	L
L	↑	L	H	H
X	X	H	X	Z

† A-to-B data flow is shown; B-to-A data flow is similar but uses $\overline{\text{CLKENBA}}$, CLKBA, and OEBA.

‡ Level of B before the indicated steady-state input conditions were established.

EPIC and Widebus are trademarks of Texas Instruments Incorporated.

PRODUCT PREVIEW information concerns products in the formative or design phase of development. Characteristic data and other specifications are design goals. Texas Instruments reserves the right to change or discontinue these products without notice.



POST OFFICE BOX 655303 • DALLAS, TEXAS 75265

Copyright © 1994, Texas Instruments Incorporated

SN74ALVC16952
16-BIT REGISTERED TRANSCEIVER
WITH 3-STATE OUTPUTS

SCAS277 - JANUARY 1993 - REVISED MARCH 1994

logic symbol†

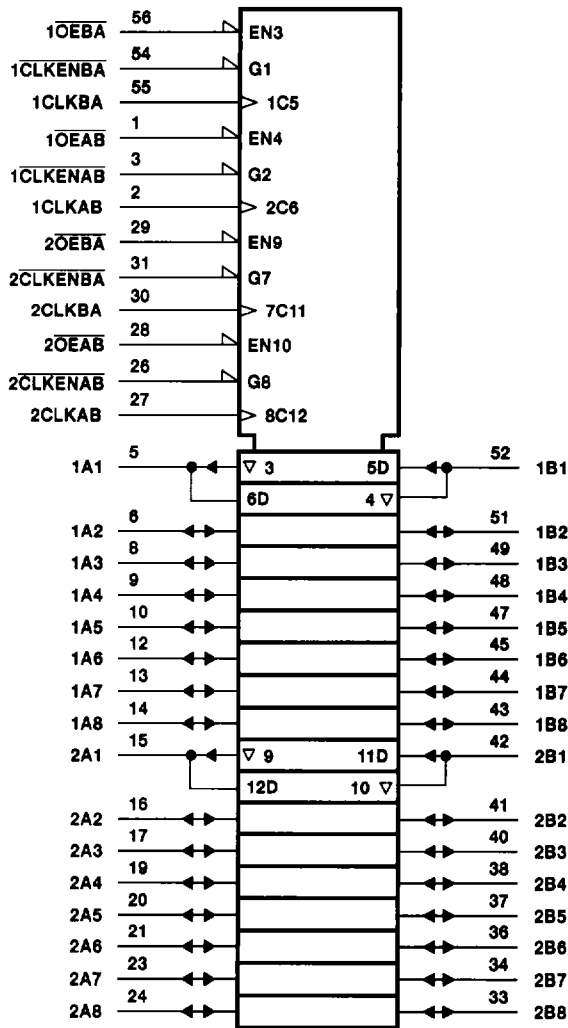

PRODUCT PREVIEW

† This symbol is in accordance with ANSI/IEEE Std 91-1984 and IEC Publication 617-12.



POST OFFICE BOX 665303 • DALLAS, TEXAS 75265

SN74ALVC16952
16-BIT REGISTERED TRANSCEIVER
WITH 3-STATE OUTPUTS

SCAS277 - JANUARY 1993 - REVISED MARCH 1994

logic diagram (positive logic)

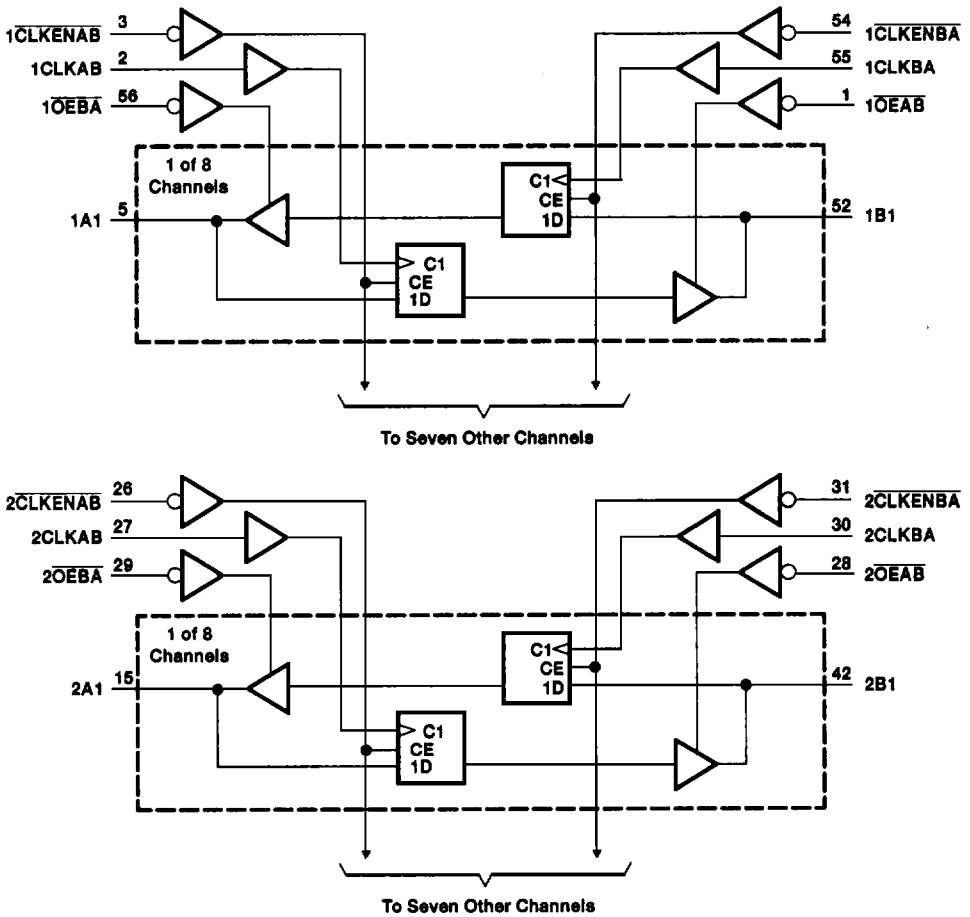

PRODUCT PREVIEW

SN74ALVC16952
16-BIT REGISTERED TRANSCEIVER
WITH 3-STATE OUTPUTS

SCAS277 – JANUARY 1993 – REVISED MARCH 1994

absolute maximum ratings over operating free-air temperature range (unless otherwise noted)†

Supply voltage range, V_{CC}	-0.5 V to 4.6 V
Input voltage range, V_I (except I/O ports) (see Note 1)	-0.5 V to 4.6 V
Input voltage range, V_I (I/O ports) (see Notes 1 and 2)	-0.5 V to $V_{CC} + 0.5$ V
Output voltage range, V_O (see Notes 1 and 2)	-0.5 V to $V_{CC} + 0.5$ V
Input clamp current, I_{IK} ($V_I < 0$)	-50 mA
Output clamp current, I_{OK} ($V_O < 0$ or $V_O > V_{CC}$)	±50 mA
Continuous output current, I_O ($V_O = 0$ to V_{CC})	±50 mA
Continuous current through V_{CC} or GND	±100 mA
Maximum power dissipation at $T_A = 55^\circ\text{C}$ (in still air) (see Note 3): DGG package	1 W
DL package	1.4 W
Storage temperature range	-65°C to 150°C

† Stresses beyond those listed under "absolute maximum ratings" may cause permanent damage to the device. These are stress ratings only, and functional operation of the device at these or any other conditions beyond those indicated under "recommended operating conditions" is not implied. Exposure to absolute-maximum-rated conditions for extended periods may affect device reliability.

- NOTES: 1. The input and output voltage ratings may be exceeded if the input and output clamp-current ratings are observed.
 2. This value is limited to 4.6 V maximum.
 3. The maximum package power dissipation is calculated using a junction temperature of 150°C and a board trace length of 750 mils. For more information, refer to the *Package Thermal Considerations* application note.

recommended operating conditions

		MIN	MAX	UNIT
V_{CC}	Supply voltage	2.7	3.6	V
V_{IH}	High-level input voltage	$V_{CC} = 2.7$ V to 3.6 V		V
V_{IL}	Low-level input voltage	$V_{CC} = 2.7$ V to 3.6 V		V
V_I	Input voltage	0	V_{CC}	V
V_O	Output voltage	0	V_{CC}	V
I_{OH}	High-level output current	$V_{CC} = 2.7$ V		mA
		$V_{CC} = 3$ V		
I_{OL}	Low-level output current	$V_{CC} = 2.7$ V		mA
		$V_{CC} = 3$ V		
$\Delta t/\Delta v$	Input transition rise or fall rate	0	10	ns/V
T_A	Operating free-air temperature	-40	85	°C

PRODUCT PREVIEW



SN74ALVC16952
16-BIT REGISTERED TRANSCEIVER
WITH 3-STATE OUTPUTS

SCAS277 – JANUARY 1993 – REVISED MARCH 1994

electrical characteristics over recommended operating free-air temperature range (unless otherwise noted)

PARAMETER		TEST CONDITIONS	V _{CC} [†]	MIN	MAX	UNIT
V _{OH}		I _{OH} = -100 μA	MIN to MAX	V _{CC} -0.2		V
		I _{OH} = -12 mA	2.7 V	2.2		
		I _{OH} = -24 mA	3 V	2.4		
V _{OL}		I _{OL} = 100 μA	MIN to MAX	0.2		V
		I _{OL} = 12 mA	2.7 V	0.4		
		I _{OL} = 24 mA	3 V	0.55		
I _I		V _I = V _{CC} or GND	3.6 V	±5		μA
I _I (hold)	Data I/Os	V _I = 0.8 V	3 V	75		μA
		V _I = 2 V		-75		
I _{OZ} [‡]		V _O = V _{CC} or GND	3.6 V	±10		μA
I _{CC}		V _I = V _{CC} or GND, I _O = 0	3.6 V	40		μA
ΔI _{CC}		V _{CC} = 3 V to 3.6 V, One input at V _{CC} - 0.6 V, Other inputs at V _{CC} or GND		750		μA
C _i	Control inputs	V _I = V _{CC} or GND	3.3 V			pF
C _{io}	A or B ports	V _O = V _{CC} or GND	3.3 V			pF

[†] For conditions shown as MIN or MAX, use the appropriate values under recommended operating conditions.

[‡] For I/O ports, the parameter I_{OZ} includes the input leakage current.

