



SOT-89-3L Plastic-Encapsulate Transistors

2SB1189 TRANSISTOR (PNP)

FEATURES

- High breakdown voltage
- Complements to 2SD1767

MAXIMUM RATINGS (T_a=25°C unless otherwise noted)

Symbol	Parameter	Value	Unit
V _{CB0}	Collector-Base Voltage	-80	V
V _{CEO}	Collector-Emitter Voltage	-80	V
V _{EBO}	Emitter-Base Voltage	-5	V
I _C	Collector Current -Continuous	-0.7	A
P _C	Collector Power Dissipation	0.5	W
T _J	Junction Temperature	150	°C
T _{stg}	Storage Temperature	-55~150	°C

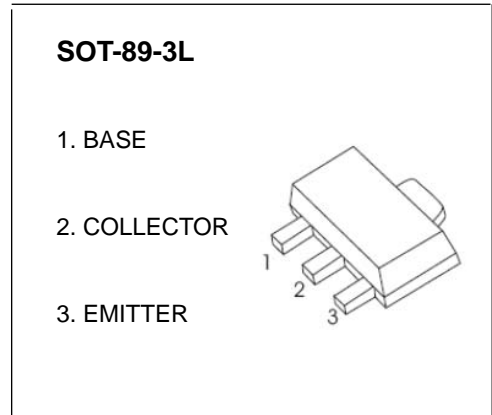

ELECTRICAL CHARACTERISTICS (T_a=25°C unless otherwise specified)

Parameter	Symbol	Test conditions	Min	Typ	Max	Unit
Collector-base breakdown voltage	V _{(BR)CBO}	I _C =-50μA, I _E =0	-80			V
Collector-emitter breakdown voltage	V _{(BR)CEO}	I _C =-2mA, I _B =0	-80			V
Emitter-base breakdown voltage	V _{(BR)EBO}	I _E =-50μA, I _C =0	-5			V
Collector cut-off current	I _{CBO}	V _{CB} =-50V, I _E =0			-0.5	μA
Emitter cut-off current	I _{EBO}	V _{EB} =-4V, I _C =0			-0.5	μA
DC current gain	h _{FE}	V _{CE} =-3V, I _C =-100mA	82		390	
Collector-emitter saturation voltage	V _{CE(sat)}	I _C =-500mA, I _B =-50mA			-0.4	V
Transition frequency	f _T	V _{CE} =-10V, I _C =-50mA, f=100MHz		100		MHz
Collector output capacitance	C _{ob}	V _{CB} =-10V, I _E =0, f=1MHz			20	pF

CLASSIFICATION OF h_{FE}

Rank	P	Q	R
Range	82-180	120-270	180-390
Marking	BDP	BDQ	BDR