

RN5RT SERIES

OUTLINE

The RN5RT Series are voltage regulator ICs with high output voltage accuracy and low supply current developed through the use of a CMOS process. Each of these voltage regulator ICs consists of a voltage reference unit, an error amplifier, output voltage setting resistors and a current limit circuit.

The output voltage of these ICs is fixed with high accuracy.

The built-in Driver Transistor of low ON Resistance permits developing of low dropout CMOS type regulator as RN5RT Series.

Even if V_{OUT} is shorted to GND, the current limit circuit protects the ICs from destruction.

Furthermore, these ICs have a chip enable function, so that the supply current on standby can be minimized.

Since the package for these ICs is the SOT-23-5 (Mini-mold) package, high density mounting of the ICs on boards is possible.

FEATURES

- Ultra-Low Supply CurrentTYP. 4 μ A (except ICEL)
- Standby ModeTYP. 0.1 μ A
- Low Dropout VoltageTYP. 0.3V ($I_{OUT}=60\text{mA}$, RN5RT30A)
- Low Temperature-Drift Coefficient of Output VoltageTYP. $\pm 100\text{ppm}/^{\circ}\text{C}$
- Excellent Line RegulationTYP. 0.15%/V
- Output VoltageStepwise setting with a step of 0.1V in the range of 2.0V to 6.0V is possible (refer to Selection Guide).
- High Accuracy Output Voltage $\pm 2.0\%$
- Built-in Current Limit CircuitsTYP. 30mA
- Small PackageSOT-23-5 (Mini-mold)

APPLICATIONS

- Power source for battery-powered equipment.
- Power source for cellular phones, cameras, VCRs, camcorders, hand-held audio instruments and hand-held communication equipment.
- Power source for domestic appliances.

BLOCK DIAGRAM

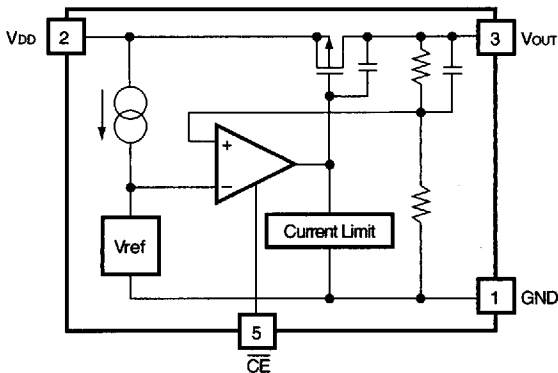

SELECTION GUIDE

The output voltage, the packing type, and the taping type for the ICs can be selected at the user's request. These selections can be made by designating the part number as shown below:

RN5RT XXXXX ← Part Number
 ↑ ↑ ↑ ↑
 a b c d

| Code | Contents |
|------|--|
| a | Setting Output Voltage (V _{OUT}) : Stepwise setting with a step of 0.1V in the range of 2.0V to 6.0V is possible. |
| b | A |
| c | Designation of Packing Type : A : Taping C : Antistatic bag (for Samples only) |
| d | Designation of Taping Type : Ex. TR, TL (refer to Taping Specifications ; TR type is the standard direction.) |

PIN CONFIGURATION

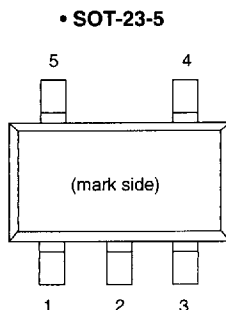

PIN DESCRIPTION

| Pin No. | Symbol | Description |
|---------|------------------------|-----------------|
| 1 | GND | Ground Pin |
| 2 | VDD | Input Pin |
| 3 | VOUT | Output Pin |
| 4 | NC | No Connection |
| 5 | $\overline{\text{CE}}$ | Chip Enable Pin |

ABSOLUTE MAXIMUM RATINGS

| Symbol | Item | Ratings | Unit |
|---------------------|---|------------------------------|------|
| V _{IN} | Input Voltage | 9 | V |
| V _{CE} | Input Voltage ($\overline{\text{CE}}$ Pin) | -0.3 to V _{IN} +0.3 | V |
| V _{OUT} | Output Voltage | -0.3 to V _{IN} +0.3 | V |
| I _{OUT} | Output Current | 150 | mA |
| P _D | Power Dissipation | 150 | mW |
| T _{opt} | Operating Temperature | -40 to +85 | °C |
| T _{stg} | Storage Temperature | -55 to +125 | °C |
| T _{solder} | Lead Temperature (Soldering) | 260°C, 10s | |

ABSOLUTE MAXIMUM RATINGS

Absolute Maximum ratings are threshold limit values that must not be exceeded even for an instant under any conditions. Moreover, such values for any two items must not be reached simultaneously. Operation above these absolute maximum ratings may cause degradation or permanent damage to the device. These are stress ratings only and do not necessarily imply functional operation below these limits.

7744690 0003989 0T5

RICOH

ELECTRICAL CHARACTERISTICS

• RN5RT30A

T_{opt}=25°C

| Symbol | Item | Conditions | MIN. | TYP. | MAX. | Unit |
|---|--|---|-------|-------|-------|--------|
| V _{OUT} | Output Voltage | V _{IN} =4.0V, I _{OUT} =10mA | 2.940 | 3.000 | 3.060 | V |
| I _{OUT} | Output Current | V _{IN} =4.0V | 40 | 60 | | mA |
| $\frac{\Delta V_{OUT}}{\Delta I_{OUT}}$ | Load Regulation | V _{IN} =4.0V 1mA ≤ I _{OUT} ≤ 60mA | | 40 | 80 | mV |
| V _{DIF} | Dropout Voltage | I _{OUT} =60mA | | 0.3 | 0.5 | V |
| I _{SS} | Supply Current | V _{IN} =4.0V (except I _{CEL}) | | 4.0 | 10 | μA |
| I _{standby} | Supply Current (Standby) | V _{IN} =V _{CE} =4.0V | | 0.1 | 1.0 | μA |
| $\frac{\Delta V_{OUT}}{\Delta V_{IN}}$ | Line Regulation | I _{OUT} =30mA V _{OUT} +0.5V ≤ V _{IN} ≤ 8V | 0 | 0.15 | 0.3 | %/V |
| V _{IN} | Input Voltage | | | | 8 | V |
| $\frac{\Delta V_{OUT}}{\Delta T_{opt}}$ | Output Voltage Temperature Coefficient | I _{OUT} =10mA -40°C ≤ T _{opt} ≤ 85°C | | ±100 | | ppm/°C |
| I _{lim} | Short Current Limit | V _{OUT} =0V | | 30 | | mA |
| V _{CEH} | \overline{CE} Input Voltage "H" | | 1.5 | | | V |
| V _{CEL} | \overline{CE} Input Voltage "L" | | | | 0.25 | V |
| I _{CEH} | \overline{CE} Input Current "H" | V _{CE} =V _{IN} | | 0 | 0.1 | μA |
| I _{CEL} | \overline{CE} Input Current "L" | V _{CE} =0V | -4.0 | -2.0 | -0.1 | μA |

• RN5RT40A

T_{opt}=25°C

| Symbol | Item | Conditions | MIN. | TYP. | MAX. | Unit |
|---|---|---|-------|-------|-------|--------|
| V _{OUT} | Output Voltage | V _{IN} =5.0V, I _{OUT} =10mA | 3.920 | 4.000 | 4.080 | V |
| I _{OUT} | Output Current | V _{IN} =5.0V | 50 | 80 | | mA |
| $\frac{\Delta V_{OUT}}{\Delta I_{OUT}}$ | Load Regulation | V _{IN} =5.0V 1mA ≤ I _{OUT} ≤ 80mA | | 40 | 80 | mV |
| V _{DIF} | Dropout Voltage | I _{OUT} =80mA | | 0.3 | 0.5 | V |
| I _{SS} | Supply Current | V _{IN} =5.0V (expect I _{CEL}) | | 4 | 10 | μA |
| I _{standby} | Supply Current (Standby) | V _{IN} =V _{CE} =5.0V | | 0.1 | 1.0 | μA |
| $\frac{\Delta V_{OUT}}{\Delta V_{IN}}$ | Line Regulation | I _{OUT} =30mA V _{OUT} +0.5V ≤ V _{IN} ≤ 8V | | 0.15 | 0.3 | %/V |
| V _{IN} | Input Voltage | | | | 8 | V |
| $\frac{\Delta V_{OUT}}{\Delta T_{opt}}$ | Output Voltage Temperature Coefficient | I _{OUT} =10mA -40°C ≤ T _{opt} ≤ 85°C | | ±100 | | ppm/°C |
| I _{lim} | Short Current Limit | V _{OUT} =0V | | 30 | | mA |
| V _{CEH} | \overline{CE} Input Voltage "H" | | 1.5 | | | V |
| V _{CEL} | \overline{CE} Input Voltage "L" | | | | 0.25 | V |
| I _{CEH} | \overline{CE} Input Current "H" | V _{CE} =V _{IN} | | 0 | 0.1 | μA |
| I _{CEL} | \overline{CE} Input Current "L" | V _{CE} =0V | -4.0 | -2.0 | -0.1 | μA |

7744690 0003991 753

RICOH

RN5RT

• RN5RT50A

T_{opt}=25°C

| Symbol | Item | Conditions | MIN. | TYP. | MAX. | Unit |
|---|---|---|-------|-------|-------|--------|
| V _{OUT} | Output Voltage | V _{IN} =6.0V, I _{OUT} =10mA | 4.900 | 5.000 | 5.100 | V |
| I _{OUT} | Output Current | V _{IN} =6.0V | 65 | 100 | | mA |
| $\frac{\Delta V_{OUT}}{\Delta I_{OUT}}$ | Load Regulation | V _{IN} =6.0V 1mA ≤ I _{OUT} ≤ 100mA | | 40 | 80 | mV |
| V _{DIF} | Dropout Voltage | I _{OUT} =100mA | | 0.3 | 0.5 | V |
| I _{SS} | Supply Current | V _{IN} =6.0V (except I _{CEL}) | | 4 | 10 | μA |
| I _{standby} | Supply Current (Standby) | V _{IN} =V _{C_{CE}} =6.0V | | 0.1 | 1.0 | μA |
| $\frac{\Delta V_{OUT}}{\Delta V_{IN}}$ | Line Regulation | I _{OUT} =30mA V _{OUT} +0.5V ≤ V _{IN} ≤ 8V | | 0.15 | 0.3 | %/V |
| V _{IN} | Input Voltage | | | | 8 | V |
| $\frac{\Delta V_{OUT}}{\Delta T_{opt}}$ | Output Voltage Temperature Coefficient | I _{OUT} =10mA -40°C ≤ T _{opt} ≤ 85°C | | ±100 | | ppm/°C |
| I _{lim} | Short Current Limit | V _{OUT} =0V | | 30 | | mA |
| V _{CEH} | \overline{CE} Input Voltage "H" | | 1.5 | | | V |
| V _{CEL} | \overline{CE} Input Voltage "L" | | | | 0.25 | V |
| I _{CEH} | \overline{CE} Input Current "H" | V _{C_{CE}} =V _{IN} | | 0 | 0.1 | μA |
| I _{CEL} | \overline{CE} Input Current "L" | V _{C_{CE}} =0V | -4.0 | -2.0 | -0.1 | μA |

7744690 0003992 69T

RICOH

PAGE (S) INTENTIONALLY BLANK

ELECTRICAL CHARACTERISTICS BY OUTPUT VOLTAGE

| Part Number | Output Voltage | | | | Output Current | | | Load Regulation | | | Dropout Voltage | | | Supply Current | | | |
|-------------|---|-------|-------|-------|----------------|--|---|--------------------------------------|------|------|---|---|------|----------------------------|------|------|--|
| | Vout (V) | | | | Iout (mA) | | | $\Delta V_{out}/\Delta I_{out}$ (mV) | | | V _{DI} F (V) | | | I _{SS} (μ A) | | | |
| | Conditions | MIN. | TYP. | MAX. | Conditions | MIN. | TYP. | Conditions | TYP. | MAX. | Conditions | TYP. | MAX. | Conditions | TYP. | MAX. | |
| RN5RT20A | V _{IN} -V _{OUT} =1.0V I _{OUT} -10mA | 1.960 | 2.000 | 2.040 | 25 | 40 | V _{IN} -V _{OUT} =1.0V 1mA \leq I _{OUT} \leq 40mA | 40 | 80 | 0.3 | 0.5 | V _{IN} -V _{OUT} =1.0V (expect I _{CEL}) | 4.0 | 10 | | | |
| RN5RT21A | | 2.058 | 2.100 | 2.142 | | | | | | | | | | | | | |
| RN5RT22A | | 2.156 | 2.200 | 2.244 | | | | | | | | | | | | | |
| RN5RT23A | | 2.254 | 2.300 | 2.346 | | | | | | | | | | | | | |
| RN5RT24A | | 2.352 | 2.400 | 2.448 | | | | | | | | | | | | | |
| RN5RT25A | | 2.450 | 2.500 | 2.550 | | | | | | | | | | | | | |
| RN5RT26A | | 2.548 | 2.600 | 2.652 | | | | | | | | | | | | | |
| RN5RT27A | | 2.646 | 2.700 | 2.754 | | | | | | | | | | | | | |
| RN5RT28A | | 2.744 | 2.800 | 2.856 | | | | | | | | | | | | | |
| RN5RT29A | | 2.842 | 2.900 | 2.958 | | | | | | | | | | | | | |
| RN5RT30A | | 2.940 | 3.000 | 3.060 | | | | | | | | | | | | | |
| RN5RT31A | | 3.038 | 3.100 | 3.162 | 40 | 60 | V _{IN} -V _{OUT} =1.0V 1mA \leq I _{OUT} \leq 60mA | 60 | 80 | 0.3 | 0.5 | V _{IN} -V _{OUT} =1.0V (expect I _{CEL}) | 4.0 | 10 | | | |
| RN5RT32A | | 3.136 | 3.200 | 3.264 | | | | | | | | | | | | | |
| RN5RT33A | | 3.234 | 3.300 | 3.366 | | | | | | | | | | | | | |
| RN5RT34A | | 3.332 | 3.400 | 3.468 | | | | | | | | | | | | | |
| RN5RT35A | | 3.430 | 3.500 | 3.570 | | | | | | | | | | | | | |
| RN5RT36A | | 3.528 | 3.600 | 3.672 | | | | | | | | | | | | | |
| RN5RT37A | | 3.626 | 3.700 | 3.774 | | | | | | | | | | | | | |
| RN5RT38A | | 3.724 | 3.800 | 3.876 | | | | | | | | | | | | | |
| RN5RT39A | | 3.822 | 3.900 | 3.978 | | | | | | | | | | | | | |
| RN5RT40A | | 3.920 | 4.000 | 4.080 | | | | | | | | | | | | | |
| RN5RT41A | | 4.018 | 4.100 | 4.182 | 50 | 80 | V _{IN} -V _{OUT} =1.0V 1mA \leq I _{OUT} \leq 80mA | 80 | 80 | 0.3 | 0.5 | V _{IN} -V _{OUT} =1.0V (expect I _{CEL}) | 4.0 | 10 | | | |
| RN5RT42A | | 4.116 | 4.200 | 4.284 | | | | | | | | | | | | | |
| RN5RT43A | | 4.214 | 4.300 | 4.386 | | | | | | | | | | | | | |
| RN5RT44A | | 4.312 | 4.400 | 4.488 | | | | | | | | | | | | | |
| RN5RT45A | | 4.410 | 4.500 | 4.590 | | | | | | | | | | | | | |
| RN5RT46A | | 4.508 | 4.600 | 4.692 | | | | | | | | | | | | | |
| RN5RT47A | | 4.606 | 4.700 | 4.794 | | | | | | | | | | | | | |
| RN5RT48A | | 4.704 | 4.800 | 4.896 | | | | | | | | | | | | | |
| RN5RT49A | | 4.802 | 4.900 | 4.998 | | | | | | | | | | | | | |
| RN5RT50A | 4.900 | 5.000 | 5.100 | | | | | | | | | | | | | | |
| RN5RT51A | 4.998 | 5.100 | 5.202 | 65 | 100 | V _{IN} -V _{OUT} =1.0V 1mA \leq I _{OUT} \leq 100mA | 100 | 80 | 0.3 | 0.5 | V _{IN} -V _{OUT} =1.0V (expect I _{CEL}) | 4.0 | 10 | | | | |
| RN5RT52A | 5.096 | 5.200 | 5.304 | | | | | | | | | | | | | | |
| RN5RT53A | 5.194 | 5.300 | 5.406 | | | | | | | | | | | | | | |
| RN5RT54A | 5.292 | 5.400 | 5.508 | | | | | | | | | | | | | | |
| RN5RT55A | 5.390 | 5.500 | 5.610 | | | | | | | | | | | | | | |
| RN5RT56A | 5.488 | 5.600 | 5.712 | | | | | | | | | | | | | | |
| RN5RT57A | 5.586 | 5.700 | 5.814 | | | | | | | | | | | | | | |
| RN5RT58A | 5.684 | 5.800 | 5.916 | | | | | | | | | | | | | | |
| RN5RT59A | 5.782 | 5.900 | 6.018 | | | | | | | | | | | | | | |
| RN5RT60A | 5.880 | 6.000 | 6.120 | | | | | | | | | | | | | | |

7744690 0003994 462



T_{opt}=25°C

| Supply Current (Standby) | | | Line Regulation | | | Input Voltage | Output Voltage Temperature Coefficient | | Short Current Limit | | CE Input Voltage | | CE Input Current | | | | | | | |
|--|------|------|---|------|------|---------------------|---|-------------------------|-----------------------|------|----------------------|--------------------------------------|-----------------------|------|-------------------------|-----------------------|------|------|------|--|
| | | | | | | | | | | | "H" | "L" | "H" | | | "L" | | | | |
| I _{standby} (μA) | | | ΔV _{out} /ΔV _{in} (%/V) | | | V _{in} (V) | ΔV _{out} /ΔT (ppm/°C) | | I _{lim} (mA) | | V _{CEH} (V) | V _{CEL} (V) | I _{CEH} (μA) | | | I _{CEL} (μA) | | | | |
| Conditions | TYP. | MAX. | Conditions | TYP. | MAX. | MAX. | Conditions | TYP. | Conditions | TYP. | MIN. | MAX. | Conditions | TYP. | MAX. | Conditions | MIN. | TYP. | MAX. | |
| V _{in} -V _{out} =1.0V | 0.1 | 1.0 | I _{OUT} = 30mA V _{OUT} + 0.5V ≤V _{IN} ≤8V | 0.15 | 0.3 | 8 | I _{OUT} = 10mA -40°C ±100 ≤T _{opt} ≤85°C | V _{OUT} =0V | 30 | 1.5 | 0.25 | V _{CE} = V _{IN} | 0 | 0.1 | V _{CE} = 0V | -4.0 | -2.0 | -0.1 | | |

7744690 0003995 3T9

RICOH

OPERATION

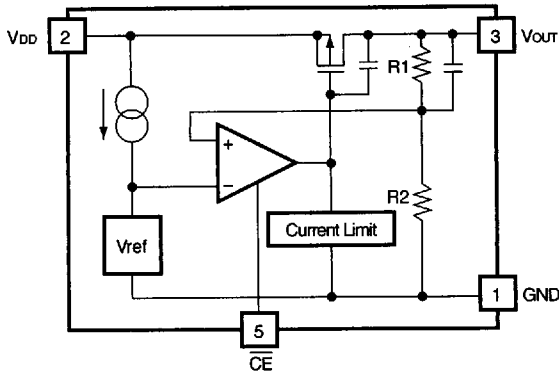

In these ICs, Output Voltage V_{OUT} is detected by Feed-back Registers R1, R2, and the detected Output Voltage is compared with a reference voltage by Error Amplifier, so that a constant voltage is output.

A current limit circuit working for Short Protect and a chip enable circuit for standby function are included.

TEST CIRCUITS

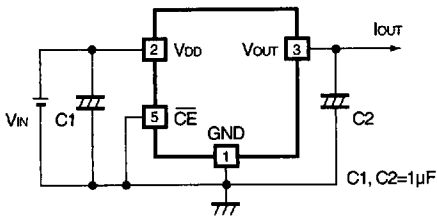

Fig.1 Standard Test Circuit

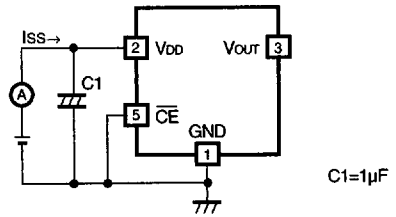

Fig.2 Supply Current Test Circuit

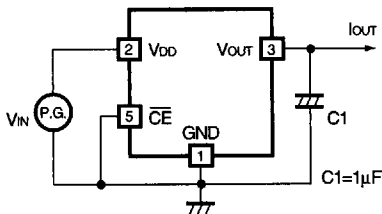
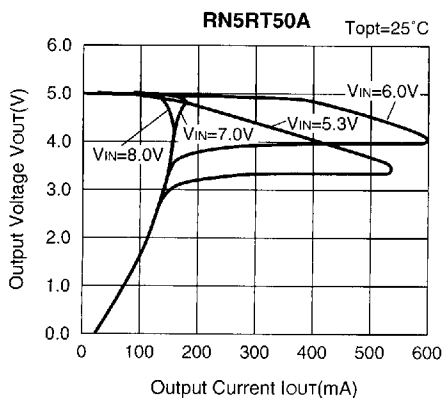
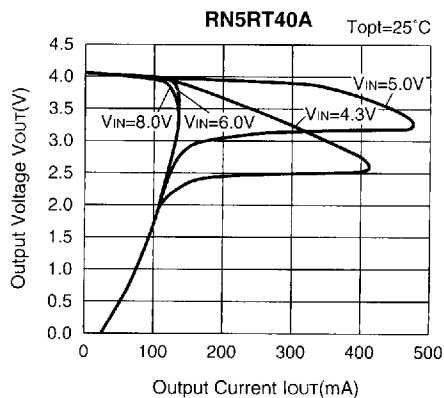
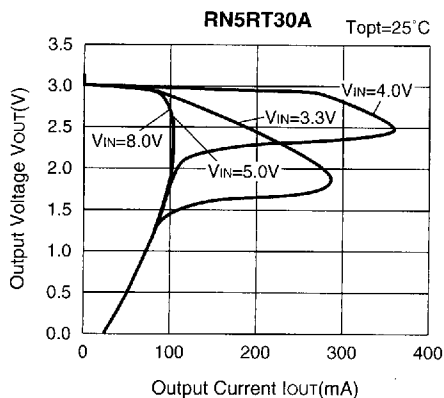

Fig.3 Line Transient Response Test Circuit

TYPICAL CHARACTERISTICS

1) Output Voltage vs. Output Current



2) Output Voltage vs. Input Voltage

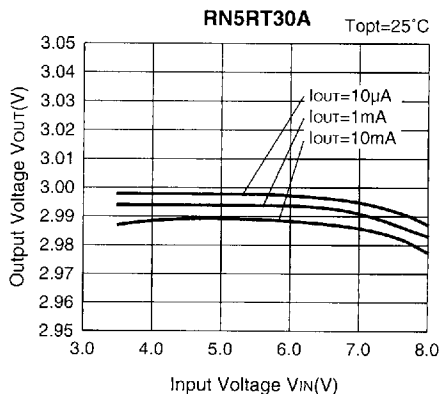
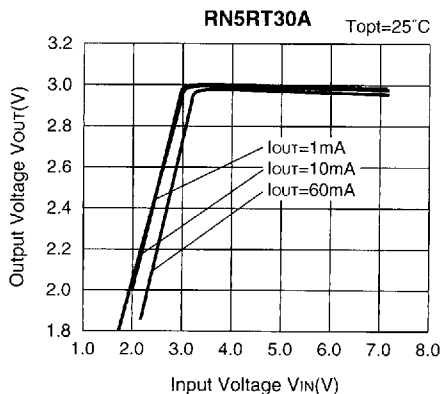

7744690 0003997 171

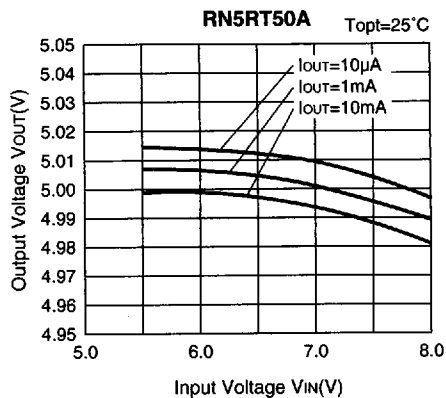
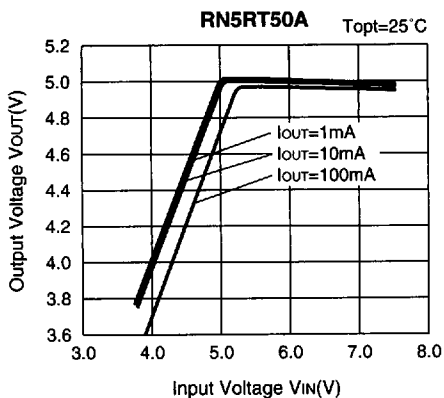
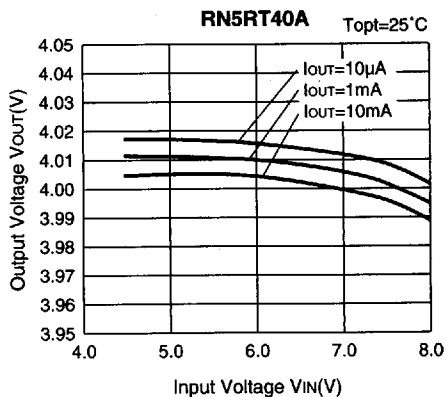
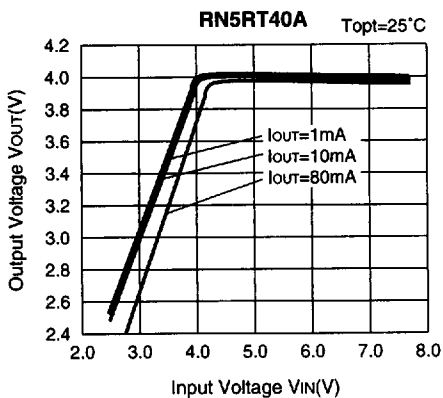

3) Dropout Voltage vs. Output Current

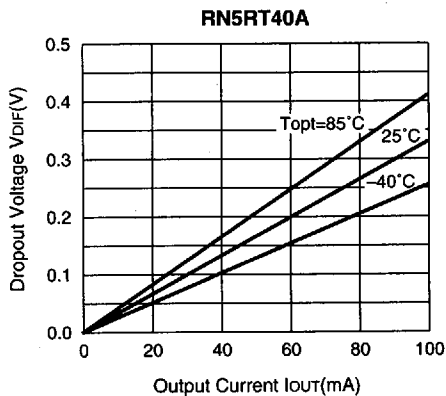
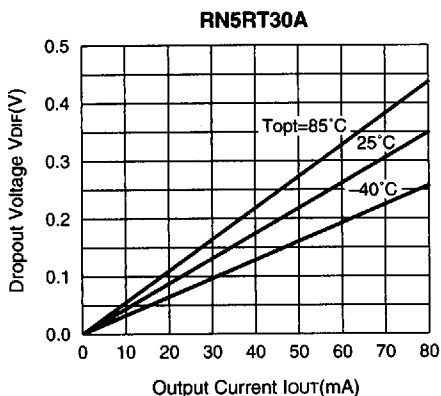

7744690 0003998 008

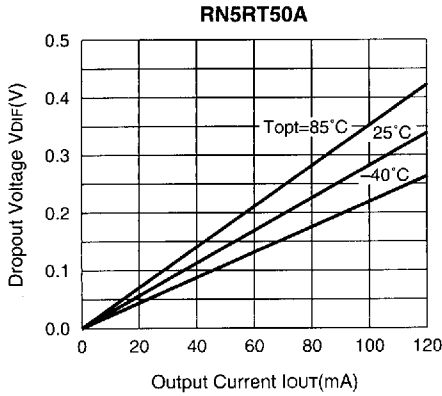

4) Output Voltage vs. Temperature

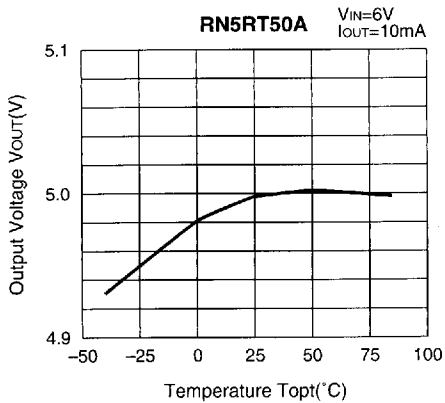
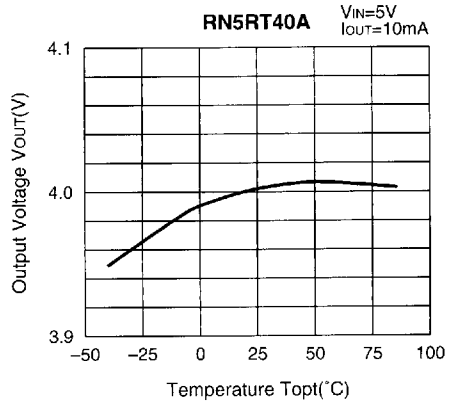
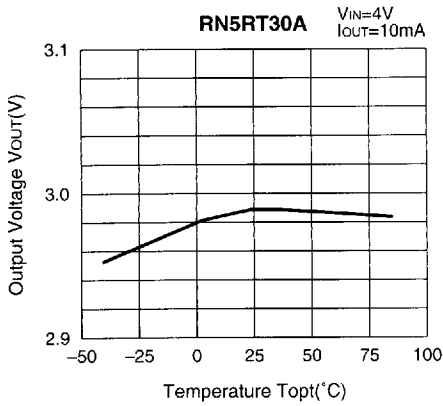

5) Supply Current vs. Input Voltage

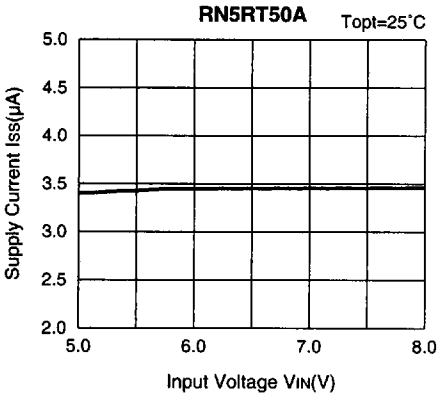
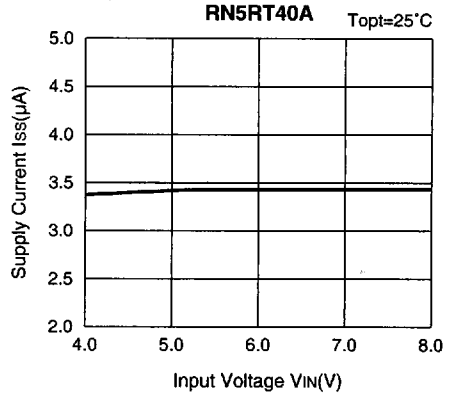
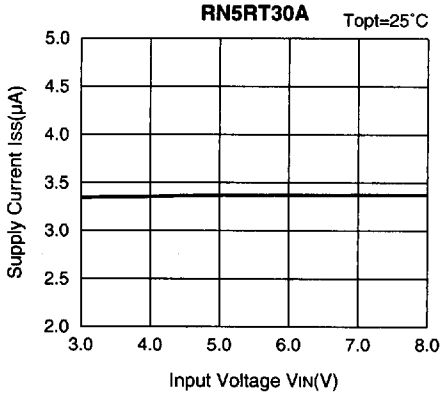

6) Supply Current vs. Temperature

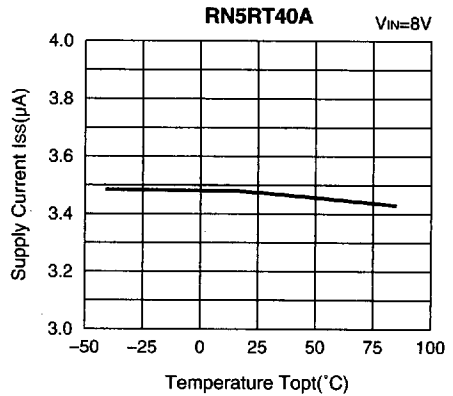
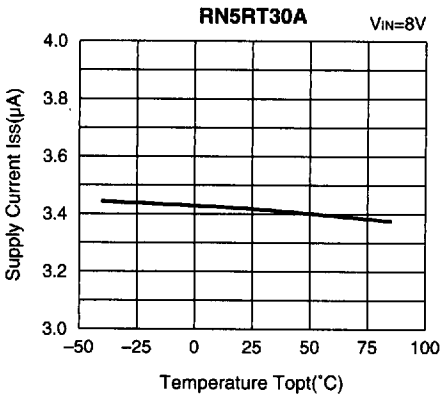

7744690 0004000 364

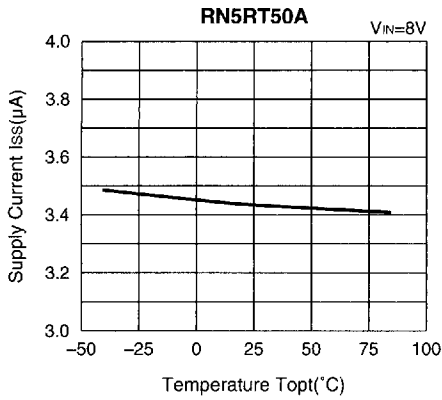

7) Dropout Voltage vs. Set Output Voltage

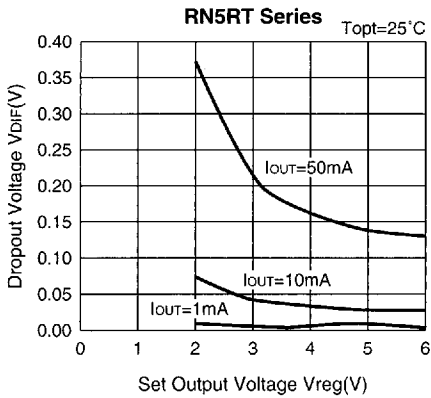

8) Line Transient Response

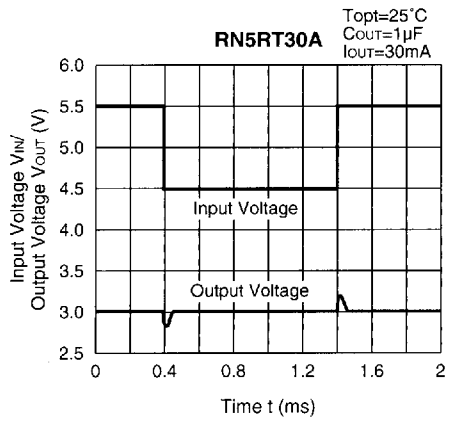
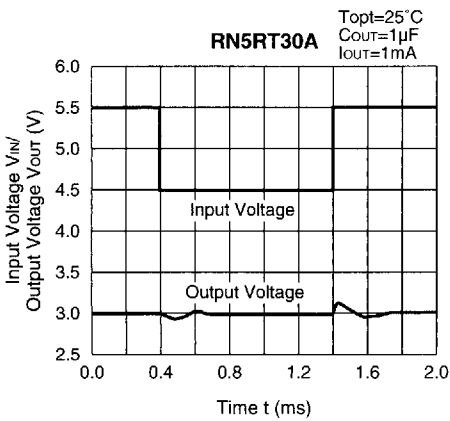

7744690 0004001 2T0

TYPICAL APPLICATION

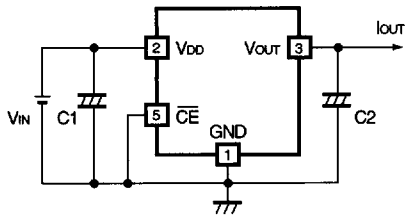

In the RN5RT Series, a constant voltage can be obtained without using Capacitor C1 and C2. However, when the wire connected to V_{IN} is long, use Capacitor C1. Transient noise of output voltage occurred due to load deviation can be reduced by using Capacitor C2.

Insert Capacitors C1 and C2 with the capacitance of 0.1 μ F to 2.0 μ F between Input/Output Pins and GND Pin with minimum wiring.