

SN54AHC16374, SN74AHC16374 16-BIT EDGE-TRIGGERED D-TYPE FLIP-FLOPS WITH 3-STATE OUTPUTS

SCLS330 – MARCH 1998

- Members of the Texas Instruments *Widebus™* Family
- Operating Range 2-V to 5.5-V V_{CC}
- 3-State Outputs Drive Bus Lines Directly
- *EPIC™* (Enhanced-Performance Implanted CMOS) Process
- Distributed V_{CC} and GND Pin Configuration Minimizes High-Speed Switching Noise
- Flow-Through Architecture Optimizes PCB Layout
- Package Options Include Plastic 300-mil Shrink Small-Outline (DL) and Thin Shrink Small-Outline (DGG) Packages and 380-mil Fine-Pitch Ceramic Flat (WD) Package Using 25-mil Center-to-Center Spacings

description

The 'AHC16374 are 16-bit edge-triggered D-type flip-flops with 3-state outputs designed specifically for driving highly capacitive or relatively low-impedance loads. They are particularly suitable for implementing buffer registers, I/O ports, bidirectional bus drivers, and working registers.

These devices can be used as two 8-bit flip-flops or one 16-bit flip-flop. On the positive transition of the clock (CLK) input, the Q outputs of the flip-flop take on the logic levels set up at the data (D) inputs.

A buffered output-enable (\overline{OE}) input can be used to place the eight outputs in either a normal logic state (high or low logic levels) or a high-impedance state. In the high-impedance state, the outputs neither load nor drive the bus lines significantly. The high-impedance state and the increased drive provide the capability to drive bus lines without need for interface or pullup components.

\overline{OE} does not affect internal operations of the flip-flop. Old data can be retained or new data can be entered while the outputs are in the high-impedance state.

The SN74AHC16374 is available in TI's shrink small-outline (DL) and thin shrink small-outline (DGG) packages, which provide twice the I/O pin count and functionality of standard small-outline packages in the same printed-circuit-board area.

The SN54AHC16374 is characterized for operation over the full military temperature range of -55°C to 125°C . The SN74AHC16374 is characterized for operation from -40°C to 85°C .

SN54AHC16374... WD PACKAGE
SN74AHC16374... DGG OR DL PACKAGE
(TOP VIEW)

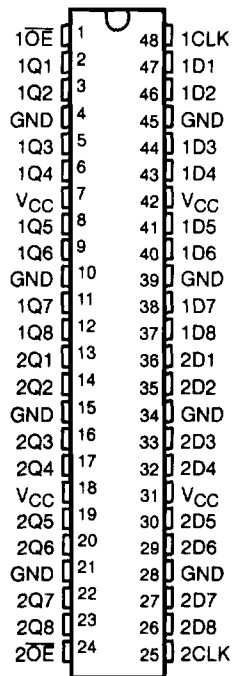

PRODUCT PREVIEW

EPIC and Widebus are trademarks of Texas Instruments Incorporated.

PRODUCT PREVIEW information concerns products in the formative or design phases of development. Characteristic data and other specifications are design goals. Texas Instruments reserves the right to change or discontinue these products without notice.



POST OFFICE BOX 655303 • DALLAS, TEXAS 75265

Copyright © 1998, Texas Instruments Incorporated

SN54AHC16374, SN74AHC16374
16-BIT EDGE-TRIGGERED D-TYPE FLIP-FLOPS
WITH 3-STATE OUTPUTS
 SCLS330 – MARCH 1996

FUNCTION TABLE
 (each flip-flop)

INPUTS			OUTPUT
\overline{OE}	CLK	D	Q
L	↑	H	H
L	↑	L	L
L	H or L	X	Q_0
H	X	X	Z

logic symbol

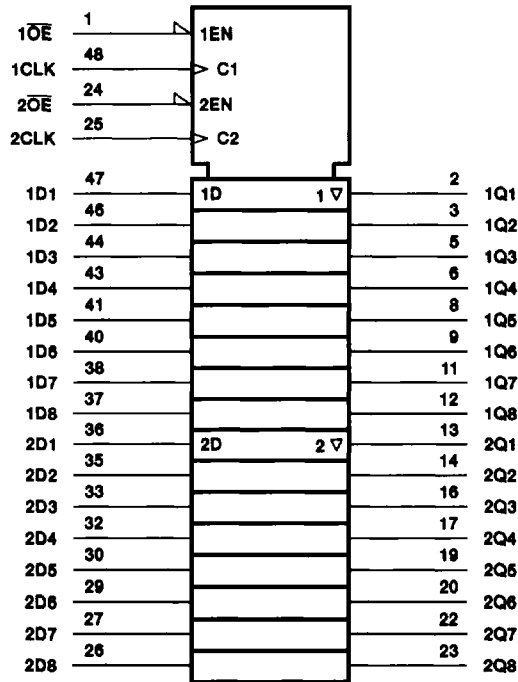

† This symbol is in accordance with ANSI/IEEE Std 91-1984 and IEC Publication 617-12.

PRODUCT PREVIEW



SN54AHC16374, SN74AHC16374 16-BIT EDGE-TRIGGERED D-TYPE FLIP-FLOPS WITH 3-STATE OUTPUTS

SCL3330 - MARCH 1996

logic diagram (positive logic)

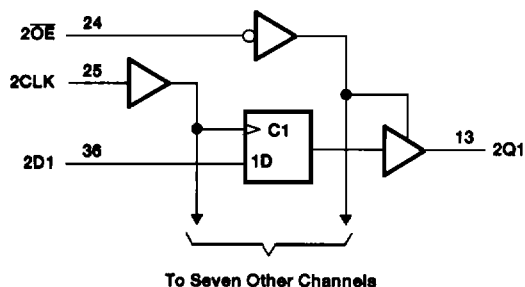
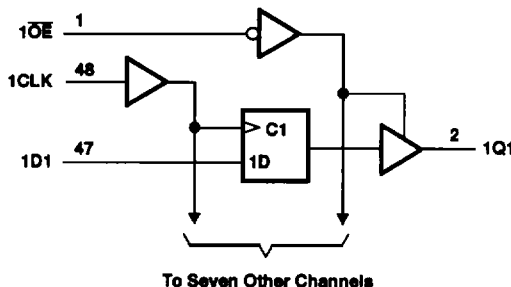

absolute maximum ratings over operating free-air temperature range (unless otherwise noted)†

Supply voltage range, V_{CC}	-0.5 V to 7 V
Input voltage range, V_I (see Note 1)	-0.5 V to 7 V
Output voltage range, V_O (see Note 1)	-0.5 V to $V_{CC} + 0.5$ V
Input clamp current, I_{IK} ($V_I < 0$ or $V_I > V_{CC}$)	-20 mA
Output clamp current, I_{OK} ($V_O < 0$ or $V_O > V_{CC}$)	± 20 mA
Continuous output current, I_O ($V_O = 0$ to V_{CC})	± 25 mA
Continuous current through each V_{CC} or GND	± 75 mA
Maximum power dissipation at $T_A = 55^\circ\text{C}$ (in still air) (see Note 2): DGG package	0.85 W
DL package	1.2 W
Storage temperature range, T_{stg}	-65°C to 150°C

† Stresses beyond those listed under "absolute maximum ratings" may cause permanent damage to the device. These are stress ratings only, and functional operation of the device at these or any other conditions beyond those indicated under "recommended operating conditions" is not implied. Exposure to absolute-maximum-rated conditions for extended periods may affect device reliability.

- NOTES: 1. The input and output voltage ratings may be exceeded if the input and output current ratings are observed.
2. The maximum package power dissipation is calculated using a junction temperature of 150°C and a board trace length of 750 mils.

PRODUCT PREVIEW



POST OFFICE BOX 656303 • DALLAS, TEXAS 75266

SN54AHC16374, SN74AHC16374
16-BIT EDGE-TRIGGERED D-TYPE FLIP-FLOPS
WITH 3-STATE OUTPUTS
 SCLS330 – MARCH 1996

recommended operating conditions (see Note 3)

		SN54AHC16374		SN74AHC16374		UNIT
		MIN	MAX	MIN	MAX	
V _{CC}	Supply voltage	2	5.5	2	5.5	V
V _{IH}	High-level input voltage	V _{CC} = 2 V		1.5		V
		V _{CC} = 3 V		2.1		
		V _{CC} = 5.5 V		3.85		
V _{IL}	Low-level input voltage	V _{CC} = 2 V		0.5		V
		V _{CC} = 3 V		0.9		
		V _{CC} = 5.5 V		1.65		
V _I	Input voltage	0	5.5	0	5.5	V
V _O	Output voltage	0	V _{CC}	0	V _{CC}	V
I _{OH}	High-level output current	V _{CC} = 2 V		-50		μA
		V _{CC} = 3.3 ± 0.3 V		-4		
		V _{CC} = 5 ± 0.5 V		-8		
I _{OL}	Low-level output current	V _{CC} = 2 V		50		μA
		V _{CC} = 3.3 ± 0.3 V		4		
		V _{CC} = 5 ± 0.5 V		8		
ΔV/Δv	Input transition rise or fall rate	V _{CC} = 3.3 ± 0.3 V		100		ns/V
		V _{CC} = 5 ± 0.5 V		20		
T _A	Operating free-air temperature	-55	125	-40	85	°C

NOTE 3: Unused inputs must be held high or low to prevent them from floating.

electrical characteristics over recommended operating free-air temperature range (unless otherwise noted)

PARAMETER	TEST CONDITIONS	V _{CC}	T _A = 25°C			SN54AHC16374		SN74AHC16374		UNIT
			MIN	TYP	MAX	MIN	MAX	MIN	MAX	
V _{OH}	I _{OH} = -50 μA	2 V	1.9	2	1.9	1.9	V			
		3 V	2.9	3	2.9	2.9				
		4.5 V	4.4	4.5	4.4	4.4				
	I _{OH} = -4 mA	3 V	2.58		2.48	2.48				
	I _{OH} = -8 mA	4.5 V	3.94		3.8	3.8				
V _{OL}	I _{OL} = 50 μA	2 V		0.1	0.1	0.1	V			
		3 V		0.1	0.1	0.1				
		4.5 V		0.1	0.1	0.1				
	I _{OL} = 4 mA	3 V		0.36	0.5	0.44				
	I _{OL} = 8 mA	4.5 V		0.36	0.5	0.44				
I _I	V _I = V _{CC} or GND	5.5 V		±0.1	±1	±1	μA			
I _{OZ}	V _O = V _{CC} or GND	5.5 V		±0.25	±2.5	±2.5	μA			
I _{CC}	V _I = V _{CC} or GND, I _O = 0	5.5 V		4	40	40	μA			
C _i	V _I = V _{CC} or GND	5 V		4	10		10	pF		
C _o	V _O = V _{CC} or GND	5 V		6				pF		

PRODUCT PREVIEW



SN54AHC16374, SN74AHC16374
16-BIT EDGE-TRIGGERED D-TYPE FLIP-FLOPS
WITH 3-STATE OUTPUTS

SCLS330 – MARCH 1996

timing requirements over recommended operating free-air temperature range, $V_{CC} = 3.3\text{ V} \pm 0.3\text{ V}$ (unless otherwise noted) (see Figure 1)

		$T_A = 25^\circ\text{C}$		SN54AHC16374		SN74AHC16374		UNIT
		MIN	MAX	MIN	MAX	MIN	MAX	
t_w	Pulse duration, CLK high or low	5		5.5		5.5		ns
t_{su}	Setup time, data before CLK \uparrow	4.5		4		4		ns
t_h	Hold time, data after CLK \uparrow	2		2		2		ns

timing requirements over recommended operating free-air temperature range, $V_{CC} = 5\text{ V} \pm 0.5\text{ V}$ (unless otherwise noted) (see Figure 1)

		$T_A = 25^\circ\text{C}$		SN54AHC16374		SN74AHC16374		UNIT
		MIN	MAX	MIN	MAX	MIN	MAX	
t_w	Pulse duration, CLK high or low	5		5		5		ns
t_{su}	Setup time, data before CLK \uparrow	3		3		3		ns
t_h	Hold time, data after CLK \uparrow	2		2		2		ns

switching characteristics over recommended operating free-air temperature range, $V_{CC} = 3.3\text{ V} \pm 0.3\text{ V}$ (unless otherwise noted) (see Figure 1)

PARAMETER	FROM (INPUT)	TO (OUTPUT)	LOAD CAPACITANCE	$T_A = 25^\circ\text{C}$			SN54AHC16374		SN74AHC16374		UNIT
				MIN	TYP	MAX	MIN	MAX	MIN	MAX	
f_{max}			$C_L = 15\text{ pF}$	80	130		70		70		MHz
			$C_L = 50\text{ pF}$	55	85		50		50		
t_{PLH}^*	CLK	Q	$C_L = 15\text{ pF}$	8.1	12.7		1	15	1	15	ns
t_{PHL}^*				8.1	12.7		1	15	1	15	
t_{PZH}^*	\overline{OE}	Q	$C_L = 15\text{ pF}$	7.1	11		1	13	1	13	ns
t_{PZL}^*				7.1	11		1	13	1	13	
t_{PHZ}^*	\overline{OE}	Q	$C_L = 15\text{ pF}$	7.5	10.5		1	12.5	1	12.5	ns
t_{PLZ}^*				7.5	10.5		1	12.5	1	12.5	
t_{PLH}	CLK	Q	$C_L = 50\text{ pF}$	10.6	16.2		1	18.5	1	18.5	ns
t_{PHL}				10.6	16.2		1	18.5	1	18.5	
t_{PZH}	\overline{OE}	Q	$C_L = 50\text{ pF}$	9.6	14.5		1	16.5	1	16.5	ns
t_{PZL}				9.6	14.5		1	16.5	1	16.5	
t_{PHZ}	\overline{OE}	Q	$C_L = 50\text{ pF}$	10.2	14		1	16	1	16	ns
t_{PLZ}				10.2	14		1	16	1	16	

* On products compliant to MIL-PRF-38535, this parameter is ensured but not production tested.

PRODUCT PREVIEW



TEXAS
INSTRUMENTS

POST OFFICE BOX 655303 • DALLAS, TEXAS 75265

SN54AHC16374, SN74AHC16374
16-BIT EDGE-TRIGGERED D-TYPE FLIP-FLOPS
WITH 3-STATE OUTPUTS

SCLS330 – MARCH 1996

switching characteristics over recommended operating free-air temperature range, $V_{CC} = 5 V \pm 0.5 V$ (unless otherwise noted) (see Figure 1)

PARAMETER	FROM (INPUT)	TO (OUTPUT)	LOAD CAPACITANCE	$T_A = 25^\circ C$			SN54AHC16374		SN74AHC16374		UNIT
				MIN	TYP	MAX	MIN	MAX	MIN	MAX	
f_{max}			$C_L = 15 \text{ pF}$	130	185		110		110	MHz	
			$C_L = 50 \text{ pF}$	85	120		75		75		
t_{PLH}^*	CLK	Q	$C_L = 15 \text{ pF}$	5.4	8.1		1	9.5	1	9.5	ns
t_{PHL}^*				5.4	8.1		1	9.5	1	9.5	
t_{PZH}^*	\overline{OE}	Q	$C_L = 15 \text{ pF}$	5.1	7.6		1	9	1	9	ns
t_{PZL}^*				5.1	7.6		1	9	1	9	
t_{PHZ}^*	\overline{OE}	Q	$C_L = 15 \text{ pF}$	4.6	6.8		1	8	1	8	ns
t_{PLZ}^*				4.6	6.8		1	8	1	8	
t_{PLH}	CLK	Q	$C_L = 50 \text{ pF}$	6.9	10.1		1	11.5	1	11.5	ns
t_{PHL}				6.9	10.1		1	11.5	1	11.5	
t_{PZH}	\overline{OE}	Q	$C_L = 50 \text{ pF}$	6.6	9.6		1	11	1	11	ns
t_{PZL}				6.6	9.6		1	11	1	11	
t_{PHZ}	\overline{OE}	Q	$C_L = 50 \text{ pF}$	6.1	8.8		1	10	1	10	ns
t_{PLZ}				6.1	8.8		1	10	1	10	

* On products compliant to MIL-PRF-38535, this parameter is ensured but not production tested.

output-skew characteristics, $C_L = 50 \text{ pF}$ (see Note 4)

PARAMETER	V_{CC}	SN74AHC16374				UNIT
		$T_A = 25^\circ C$		MIN	MAX	
		MIN	MAX			
$t_{sk(o)}$ Output skew	$3.3 V \pm 0.3 V$		1.5		1.5	ns
	$5 V \pm 0.5 V$		1		1	

NOTE 4: Characteristics are determined during product characterization and ensured by design.

noise characteristics, $V_{CC} = 5 V$, $C_L = 50 \text{ pF}$, $T_A = 25^\circ C$ (see Note 5)

PARAMETER	SN74AHC16374			UNIT
	MIN	TYP	MAX	
$V_{OL(P)}$ Quiet output, maximum dynamic V_{OL}		0.5	1	V
$V_{OL(V)}$ Quiet output, minimum dynamic V_{OL}		-0.5	-0.8	V
$V_{OH(V)}$ Quiet output, minimum dynamic V_{OH}		4		V
$V_{IH(D)}$ High-level dynamic input voltage		3.5		V
$V_{IL(D)}$ Low-level dynamic input voltage			1.5	V

NOTE 5: Characteristics are determined during product characterization and ensured by design for surface-mount packages only.

operating characteristics, $V_{CC} = 5 V$, $T_A = 25^\circ C$

PARAMETER	TEST CONDITIONS	TYP	UNIT
C_{pd} Power dissipation capacitance	No load, $f = 1 \text{ MHz}$	32	pF

PRODUCT PREVIEW



POST OFFICE BOX 655303 • DALLAS, TEXAS 75265

PARAMETER MEASUREMENT INFORMATION

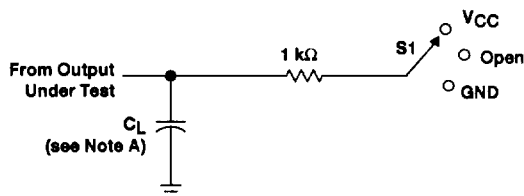

LOAD CIRCUIT

TEST	S1
tPLH/tPHL	Open
tPLZ/tPZL	VCC
tPHZ/tPZH	GND

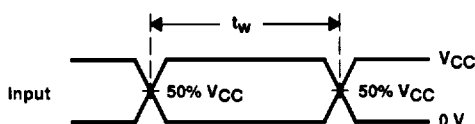

VOLTAGE WAVEFORMS
PULSE DURATION

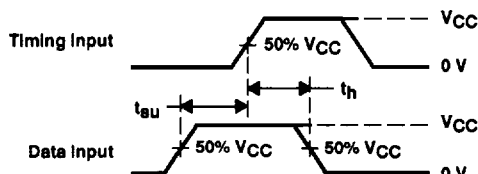

VOLTAGE WAVEFORMS
SETUP AND HOLD TIMES

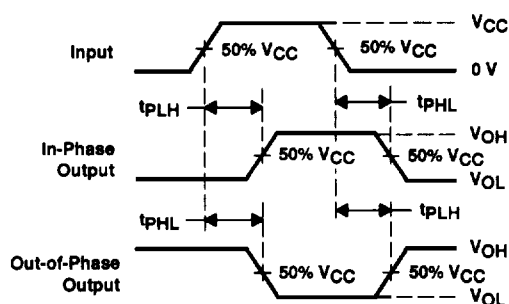

VOLTAGE WAVEFORMS
DELAY TIMES

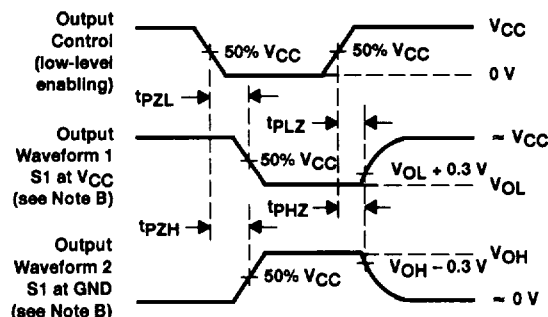

VOLTAGE WAVEFORMS
ENABLE AND DISABLE TIMES

- NOTES: A. CL includes probe and jig capacitance.
B. Waveform 1 is for an output with internal conditions such that the output is low except when disabled by the output control. Waveform 2 is for an output with internal conditions such that the output is high except when disabled by the output control.
C. All input pulses are supplied by generators having the following characteristics: PRR ≤ 1 MHz, ZO = 50 Ω, tr = 3 ns, tf = 3 ns.
D. The outputs are measured one at a time with one input transition per measurement.

Figure 1. Load Circuit and Voltage Waveforms

PRODUCT PREVIEW