

NUMBER
C-1734804

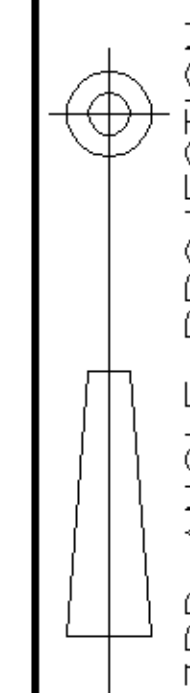

METRIC

THIS INFORMATION IS CONFIDENTIAL AND IS DISCLOSED TO YOU ON CONDITION THAT NO FURTHER DISCLOSURE IS MADE BY YOU TO OTHER THAN AMP PERSONNEL WITHOUT WRITTEN AUTHORIZATION FROM AMP (TAIWAN) LTD. DIMENSIONS IN MILLIMETERS. DO NOT SCALE PRINT.

PRINT
DW

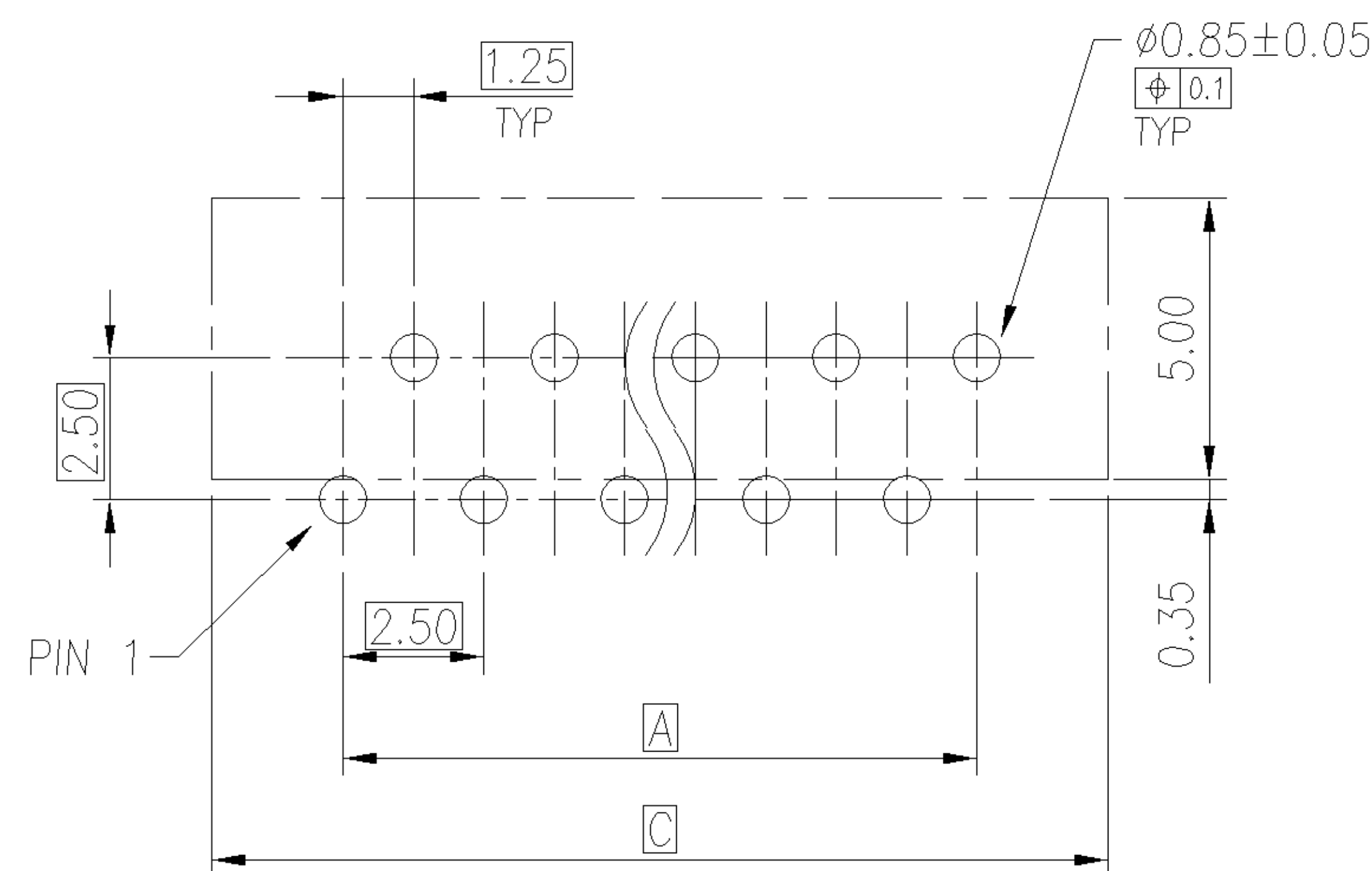
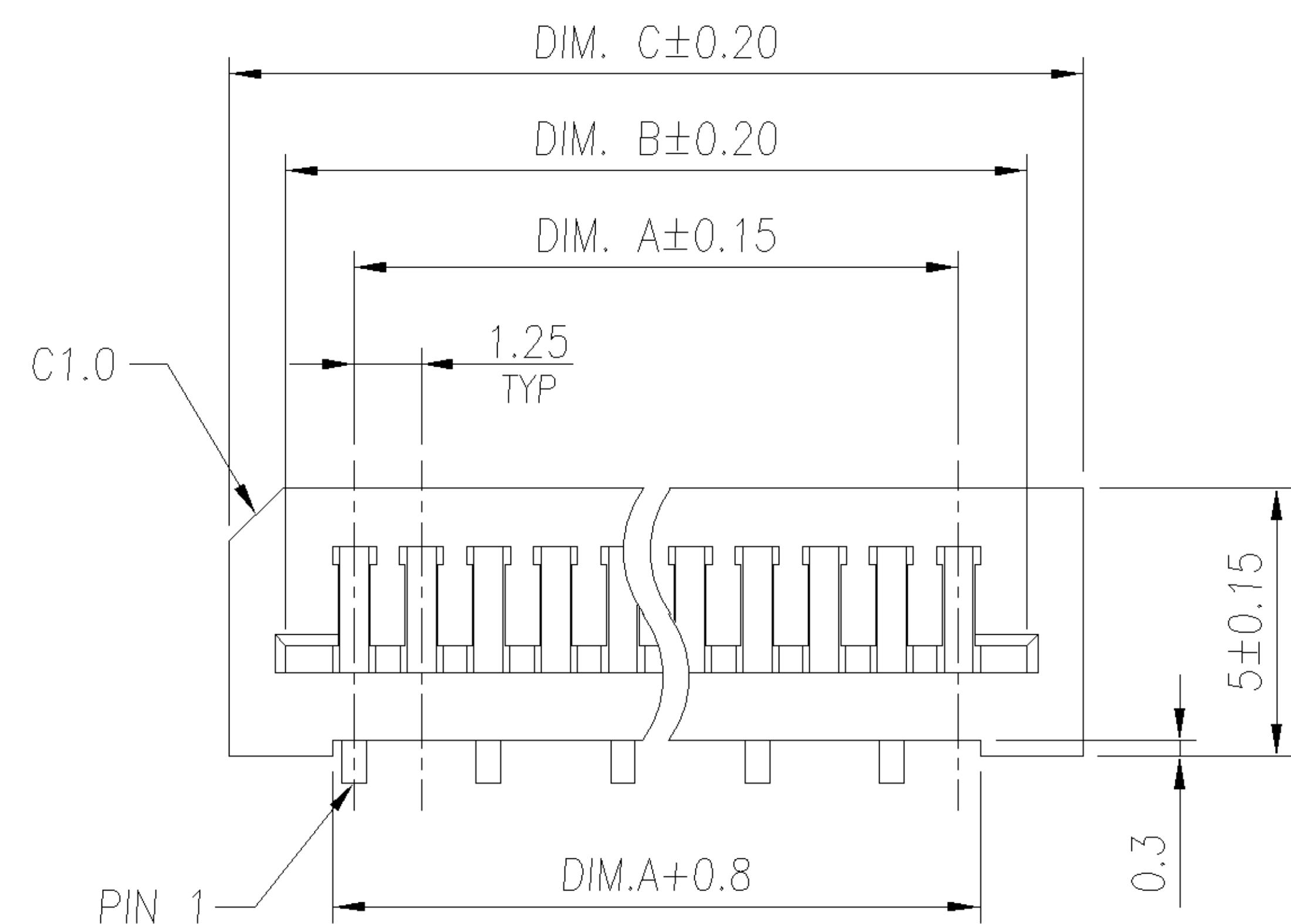

RECOMMENDED PCB LAYOUT
PCB TOLERANCE: ±0.05

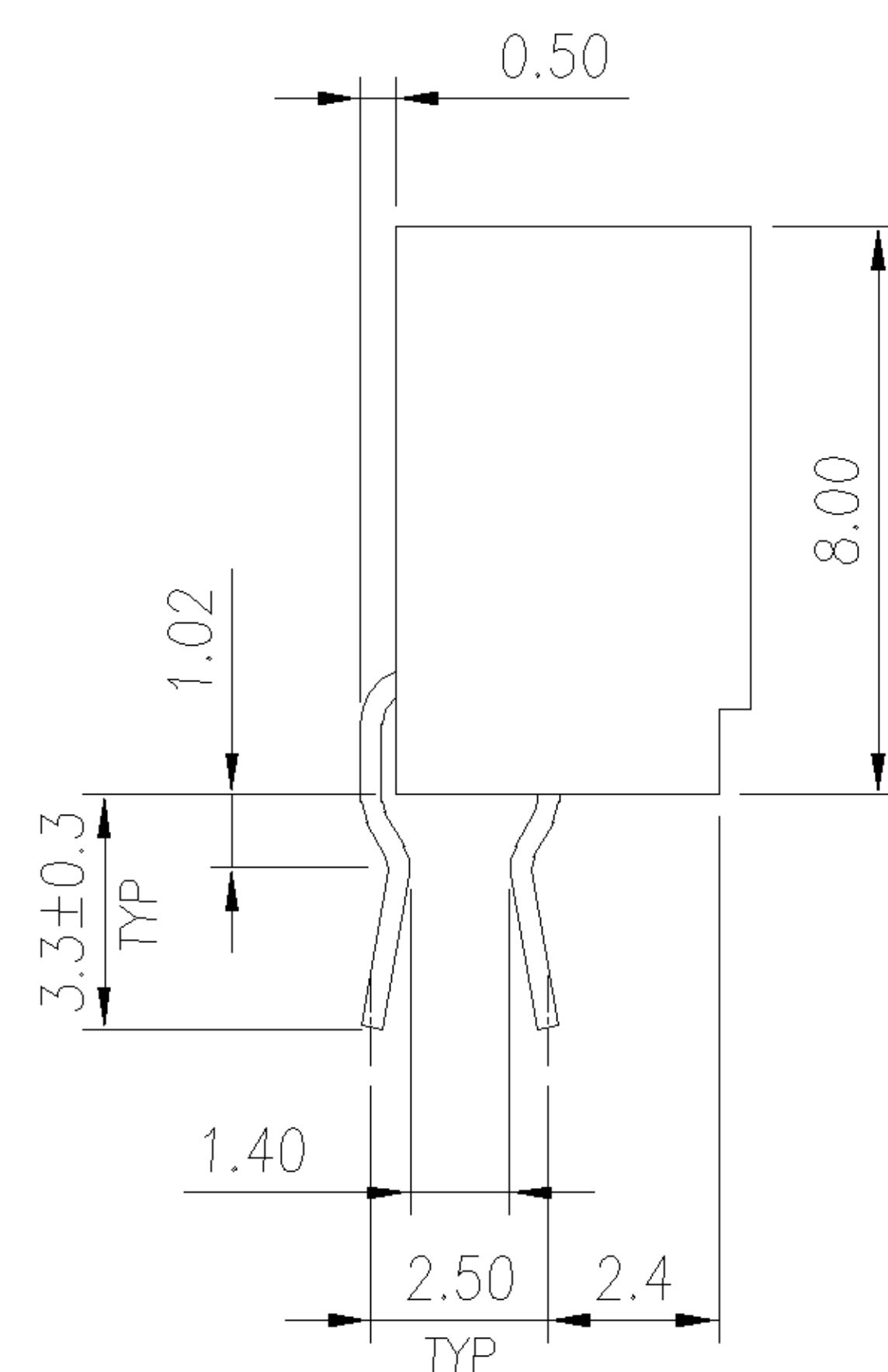
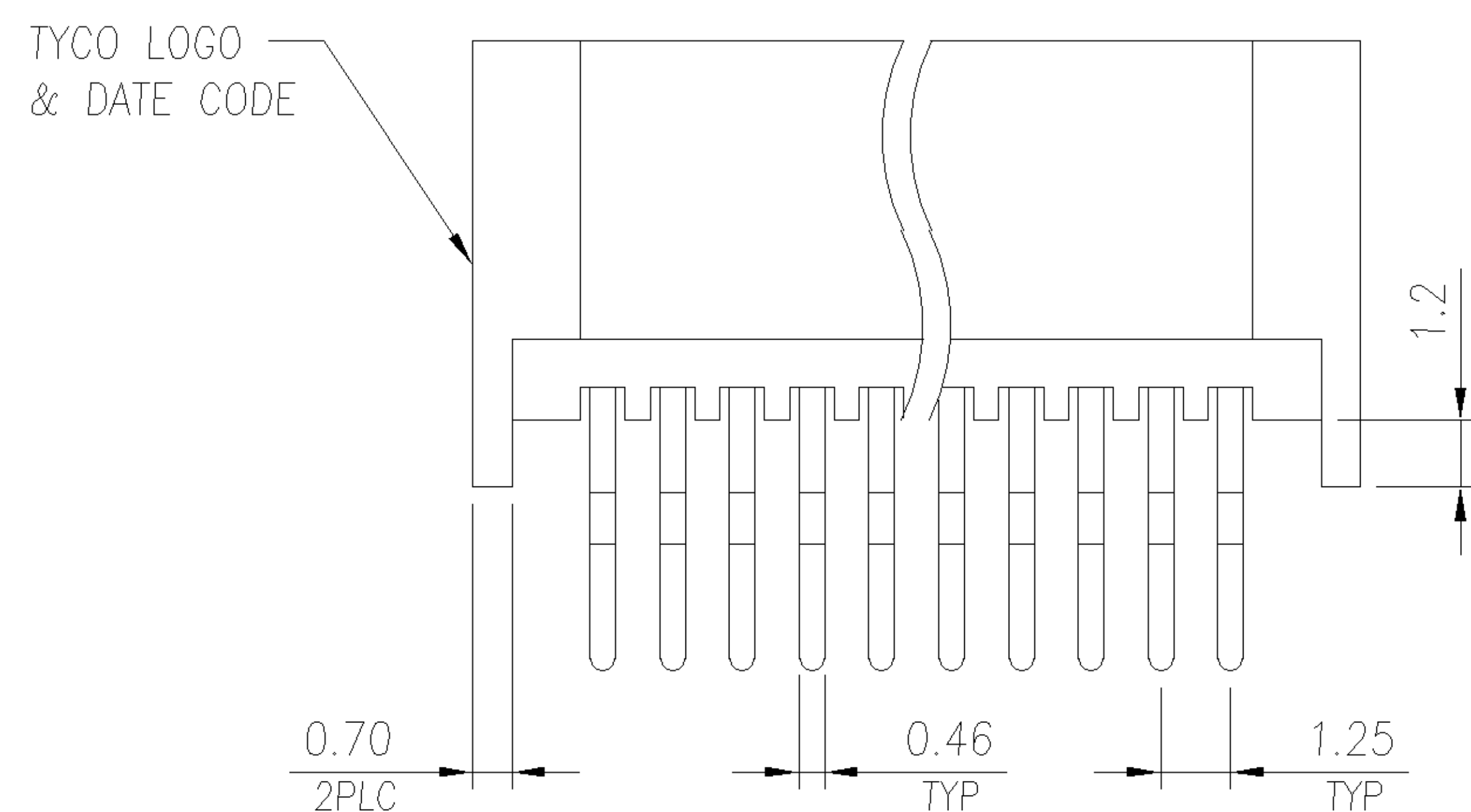

NOTES:

1. MATERIAL:
 - 1.1 HOUSING: THERMOPLASTIC (PBT), UL94V-0; COLOR: BLACK.
 - 1.2 CONTACTS: PHOSPHOR BRONZE.
2. FINISH:

CONTACT:

 - 100μ" MIN. BRIGHT TIN PLATING
 - 50μ" MIN. NICKEL UNDERPLATING OVERALL.
3. RECOMMENDED PCB THICKNESS: 1.57mm.
4. WAVE SOLDER CAPABLE TO 265°C PER TYCO SPEC. 109-202, CONDITION B.

48.40	46.30	43.75	36	3-	-6
47.15	45.05	42.50	35	3-	-5
45.90	43.80	41.25	34	3-	-4
44.65	42.55	40.00	33	3-	-3
43.40	41.30	38.75	32	3-	-2
42.15	40.05	37.50	31	3-	-1
40.90	38.80	36.25	30	3-	-0
39.65	37.55	35.00	29	2-	-9
38.40	36.30	33.75	28	2-	-8
37.15	35.05	32.50	27	2-	-7
35.90	33.80	31.25	26	2-	-6
34.65	32.55	30.00	25	2-	-5
33.40	31.30	28.75	24	2-	-4
32.15	30.05	27.50	23	2-	-3
30.90	28.80	26.25	22	2-	-2
29.65	27.55	25.00	21	2-	-1
28.40	26.30	23.75	20	2-	-0
27.15	25.05	22.50	19	1-	-9
25.90	23.80	21.25	18	1-	-8
24.65	22.55	20.00	17	1-	-7
23.40	21.30	18.75	16	1-	-6
22.15	20.05	17.50	15	1-	-5
20.90	18.80	16.25	14	1-	-4
19.65	17.55	15.00	13	1-	-3
18.40	16.30	13.75	12	1-	-2
17.15	15.05	12.50	11	1-	-1
15.90	13.80	11.25	10	1-	-0
14.65	12.55	10.00	9		-9
13.40	11.30	8.75	8		-8
12.15	10.05	7.50	7		-7
10.90	8.80	6.25	6		-6
9.65	7.55	5.00	5		-5
8.40	6.30	3.75	4		1734804-4
DIM. C	DIM. B	DIM. A	POS. NO	PART NUMBER	

TOLERANCES UNLESS OTHERWISE SPECIFIED:		DWN		J. LEE		tyco		TYCO HOLDINGS (BERMUDA)	
0 PLC ±		22-MAR-2006		S. HOU		Electronics		VII LTD. TAIWAN BRANCH	
1 PLC ±0.3		APVD		W.J. KE		NAME		FPC NON ZIF, VERTICAL	
2 PLC ±0.2		PRODUCT SPEC		108-57612		LOC		SIZE	
3 PLC ±0.1		FINISH		501-57711		DRAWING NO		REV	
ANGLES ± 3'		SEE NOTE		WEIGHT		SCALE		SHEET	
A		FIRST RELEASED		---		C-1734804		A	
LTR		REVISION RECORD		ECN		---		1 OF 2	
		JL		22-MAR					
		SH		2006					
		DWN		CHK					
		DATE							

NUMBER
C-1734804

3RD ANGLE PROJECTION

METRIC

THIS INFORMATION IS CONFIDENTIAL AND IS DISCLOSED TO YOU ON CONDITION THAT NO FURTHER DISCLOSURE IS MADE BY YOU TO OTHER THAN AMP PERSONNEL WITHOUT WRITTEN AUTHORIZATION FROM AMP (TAIWAN) LTD. DIMENSIONS IN MILLIMETERS. DO NOT SCALE PRINT.

PRINT
DW

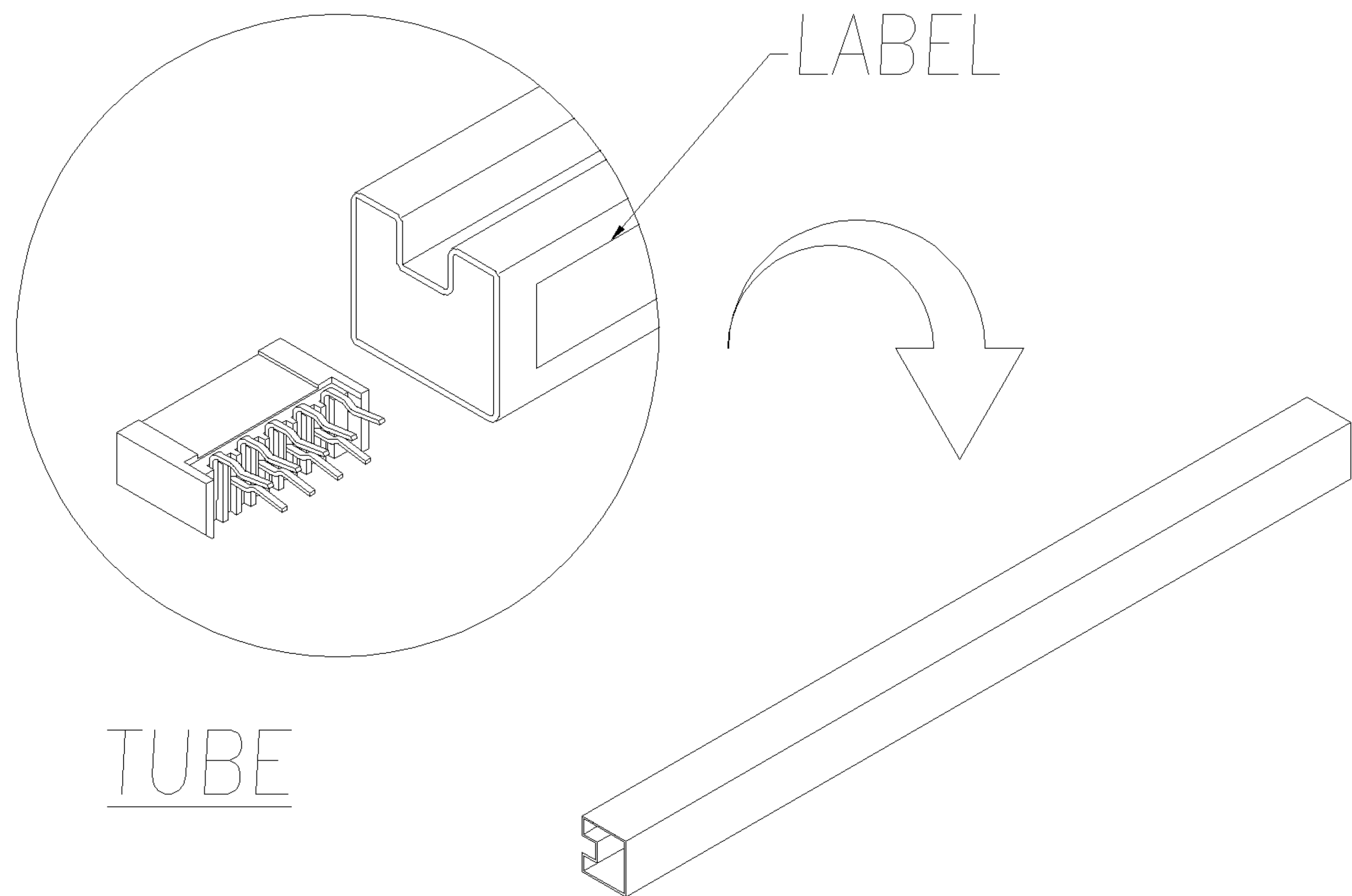

TUBE

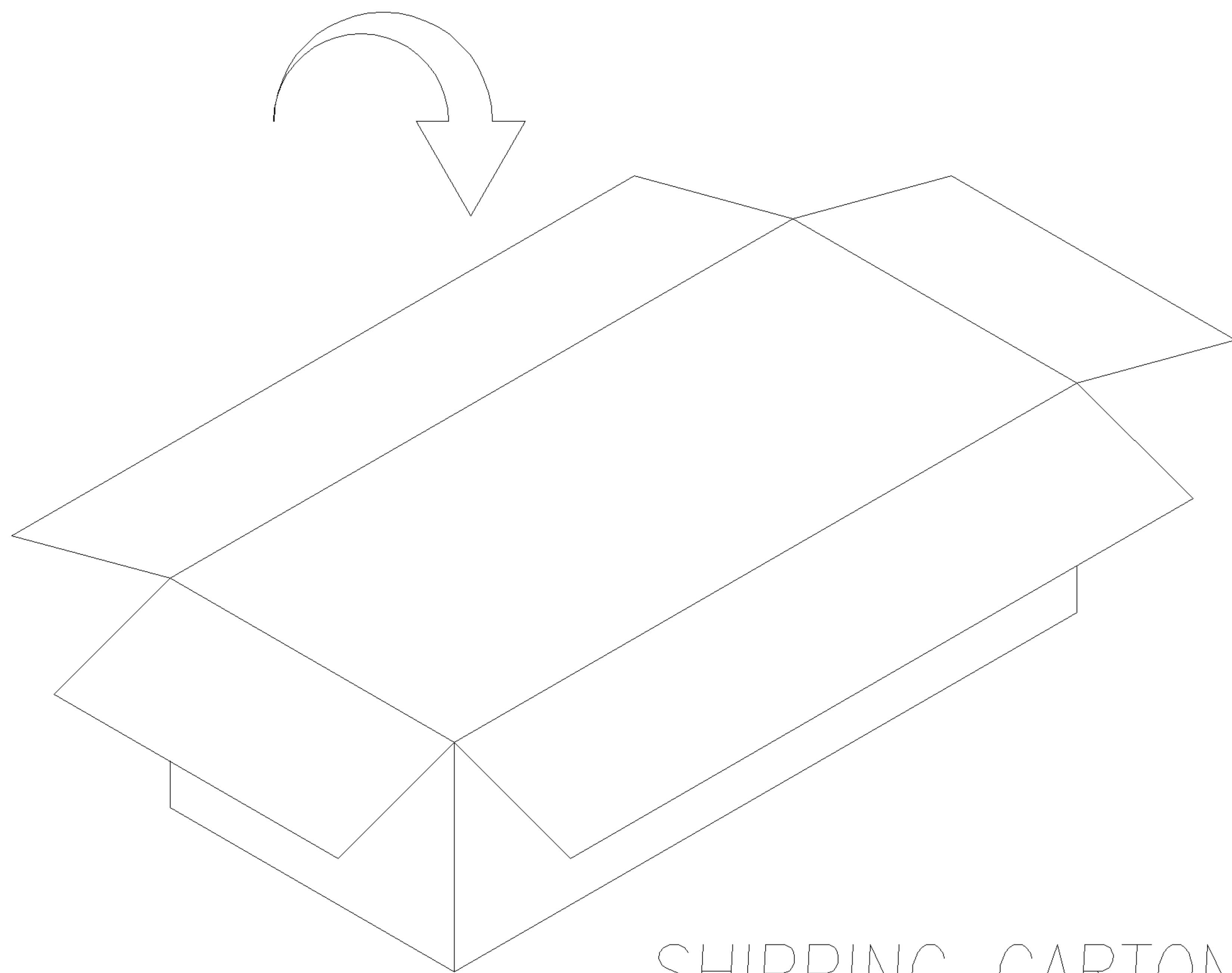

SHIPPING CARTON

NOTES:

- MATERIAL:
TUBE: PVC
CARTON: CORRUGATED PAPER
- DIMENSION:
TUBE: L=636, W=15.2, H=10.6
CARTON: L=650, W=225, H=180
- QUANTITY:
224 TUBES/SHIPPING BOX
DETAIL QUANTITY: SEE TABLE

POS. NO	PACKAGING QUANTITY (PCS)		NET WEIGHT(Kg)	GROSS WEIGHT(Kg)
	PER TUBE	SHIPPING BOX		
4	73	16352	6.61	11.78
5	63	14112	6.60	11.77
6	55	12320	6.67	11.84
7	50	11200	6.66	11.83
8	45	10080	6.55	11.72
9	41	9184	6.53	11.70
10	38	8512	6.60	11.77
11	35	7840	6.57	11.74
12	33	7392	6.67	11.84
13	31	6944	6.57	11.74
14	29	6496	6.62	11.79
15	27	6048	6.55	11.72
16	26	5824	6.67	11.84
17	24	5376	6.50	11.67
18	23	5152	6.51	11.68
19	22	4928	6.59	11.76
20	21	4704	6.54	11.71

POS. NO	PACKAGING QUANTITY (PCS)		NET WEIGHT(Kg)	GROSS WEIGHT(Kg)
	PER TUBE	SHIPPING BOX		
21	20	4480	6.47	11.64
22	19	4256	6.37	11.54
23	19	4256	6.73	11.90
24	18	4032	6.59	11.76
25	17	3808	6.46	11.63
26	17	3808	6.71	11.88
27	16	3584	6.54	11.71
28	15	3360	6.34	11.51
29	15	3360	6.56	11.73
30	14	3136	6.32	11.49
31	14	3136	6.52	11.69
32	14	3136	6.72	11.89
33	13	2912	6.42	11.59
34	13	2912	6.61	11.78
35	13	2912	6.79	11.96
36	12	2688	6.44	11.61

TOLERANCES UNLESS OTHERWISE SPECIFIED: 0 PLC ± 1 PLC ± 2 PLC ± 3 PLC ± ANGLES ±		DWN J. LEE 22-MAR-2006	tyco TYCO HOLDINGS (BERMUDA) VII LTD. TAIWAN BRANCH	
MATERIAL SEE NOTE		CHK S. HOU 22-MAR-2006	NAME FPC NON ZIF, VERTICAL 1.25 PITCH, DIP	
FINISH SEE NOTE		APVD W.J. KE 21-MAR-2005	LOC DW	REV A
		PRODUCT SPEC	SIZE A ₃	DRAWING NO C-1734804
		QUALIFICATION TEST REPORT	SCALE --	SHEET 2 OF 2
		WEIGHT		

SEE SHEET 1				
LTR	REVISION RECORD	ECN	DWN CHK	DATE