

**Rochester Electronics
Manufactured Components**

Rochester branded components are manufactured using either die/wafers purchased from the original suppliers or Rochester wafers recreated from the original IP. All recreations are done with the approval of the OCM.

Parts are tested using original factory test programs or Rochester developed test solutions to guarantee product meets or exceed the OCM data sheet.

Quality Overview

- ISO-9001
- AS9120 certification
- Qualified Manufacturers List (QML) MIL-PRF-35835
 - Class Q Military
 - Class V Space Level
- Qualified Suppliers List of Distributors (QSLD)
 - Rochester is a critical supplier to DLA and meets all industry and DLA standards.

Rochester Electronics, LLC is committed to supplying products that satisfy customer expectations for quality and are equal to those originally supplied by industry manufacturers.

The original manufacturer's datasheet accompanying this document reflects the performance and specifications of the Rochester manufactured version of this device. Rochester Electronics guarantees the performance of its semiconductor products to the original OEM specifications. 'Typical' values are for reference purposes only. Certain minimum or maximum ratings may be based on product characterization, design, simulation, or sample testing.

SN54174, SN54175, SN54LS174, SN54LS175, SN54S174, SN54S175, SN74174, SN74175, SN74LS174, SN74LS175, SN74S174, SN74S175 HEX/QUADRUPLE D-TYPE FLIP-FLOPS WITH CLEAR

SDLS068A – DECEMBER 1972 – REVISED OCTOBER 2001

'174, 'LS174, 'S174 ... HEX D-TYPE FLIP-FLOPS
'175, 'LS175, 'S175 ... QUADRUPLE D-TYPE FLIP-FLOPS

- '174, 'LS174, 'S174 Contain Six Flip-Flops with Single-Rail Outputs
- '175, 'LS175, 'S175 Contain Four Flip-Flops with Double-Rail Outputs
- Three Performance Ranges Offered: See Table Lower Right
- Buffered Clock and Direct Clear Inputs
- Individual Data Input to Each Flip-Flop
- Applications include:
 - Buffer/Storage Registers
 - Shift Registers
 - Pattern Generators

SN54174, SN54LS174, SN54S174 ... J OR W PACKAGE
SN74174 ... N PACKAGE
SN74LS174, SN74S174 ... D OR N PACKAGE

(TOP VIEW)

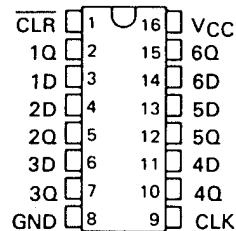

SN54LS174, SN54S174 ... FK PACKAGE

(TOP VIEW)

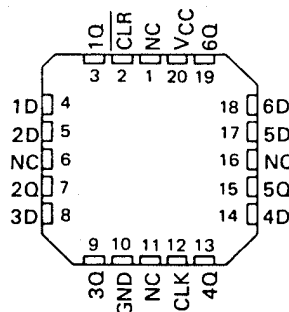

SN54175, SN54LS175, SN54S175 ... J OR W PACKAGE
SN74175 ... N PACKAGE
SN74LS175, SN74S175 ... D OR N PACKAGE

(TOP VIEW)

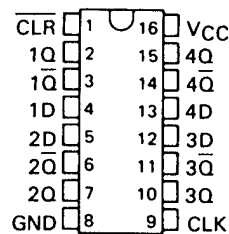

SN54LS175, SN54S175 ... FK PACKAGE

(TOP VIEW)

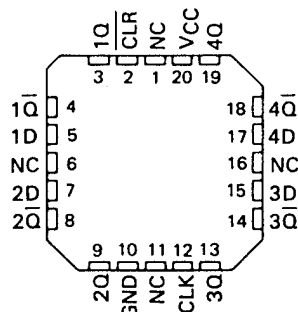

NC – No internal connection

description

These monolithic, positive-edge-triggered flip-flops utilize TTL circuitry to implement D-type flip-flop logic. All have a direct clear input, and the '175, 'LS175, and 'S175 feature complementary outputs from each flip-flop.

Information at the D inputs meeting the setup time requirements is transferred to the Q outputs on the positive-going edge of the clock pulse. Clock triggering occurs at a particular voltage level and is not directly related to the transition time of the positive-going pulse. When the clock input is at either the high or low level, the D input signal has no effect at the output.

These circuits are fully compatible for use with most TTL circuits.

FUNCTION TABLE
(EACH FLIP-FLOP)

INPUTS			OUTPUTS	
CLEAR	CLOCK	D	Q	\bar{Q} †
L	X	X	L	H
H	↑	H	H	L
H	↑	L	L	H
H	L	X	Q_0	\bar{Q}_0

H = high level (steady state)

L = low level (steady state)

X = irrelevant

↑ = transition from low to high level

Q_0 = the level of Q before the indicated steady-state input conditions were established.

† = '175, 'LS175, and 'S175 only

TYPES	TYPICAL	TYPICAL
	MAXIMUM	POWER
	CLOCK	DISSIPATION
	FREQUENCY	PER FLIP-FLOP
'174, '175	35 MHz	38 mW
'LS174, 'LS175	40 MHz	14 mW
'S174, 'S175	110 MHz	75 mW

PRODUCTION DATA information is current as of publication date. Products conform to specifications per the terms of Texas Instruments standard warranty. Production processing does not necessarily include testing of all parameters.

 **TEXAS
INSTRUMENTS**

POST OFFICE BOX 655303 • DALLAS, TEXAS 75265

Copyright © 2001, Texas Instruments Incorporated

SN54174, SN54175, SN54LS174, SN54LS175, SN54S174, SN54S175, SN74174, SN74175, SN74LS174, SN74LS175, SN74S174, SN74S175 HEX/QUADRUPLE D-TYPE FLIP-FLOPS WITH CLEAR

SDLS068A - DECEMBER 1972 - REVISED OCTOBER 2001

logic symbols†

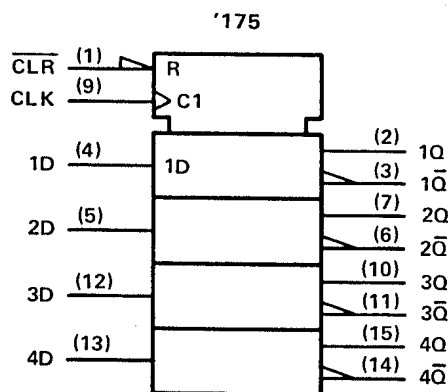
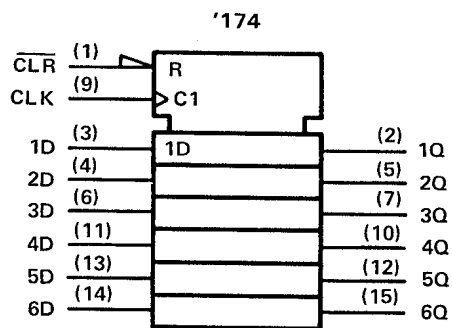

†These symbols are in accordance with ANSI/IEEE Std. 91-1984 and IEC Publication 617-12. Pin numbers shown are for D, J, N, and W packages.

logic diagrams (positive logic)

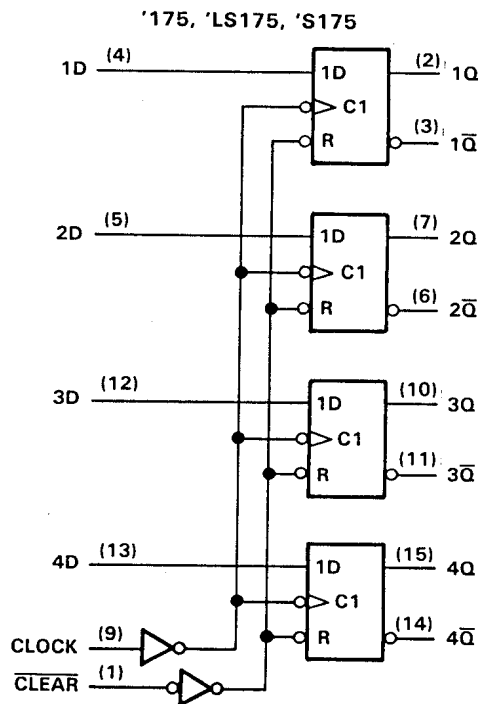
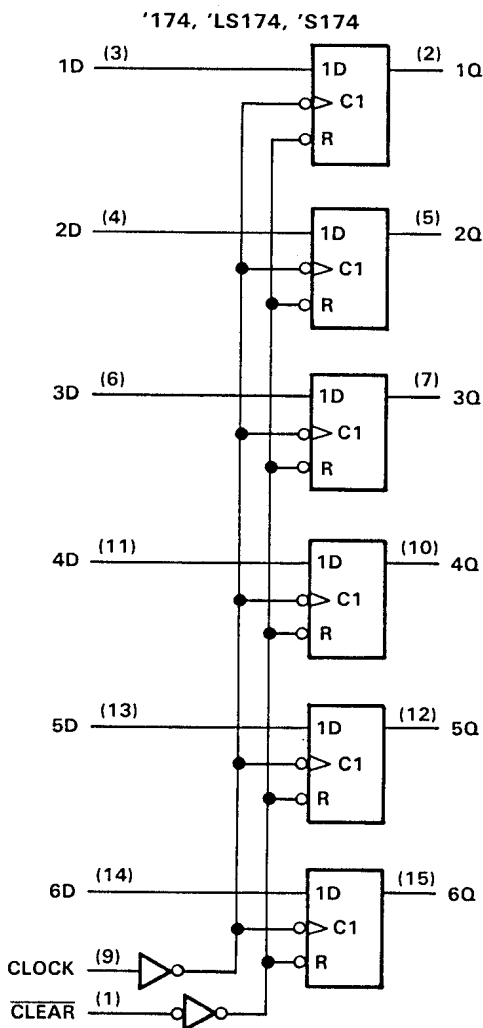

Pin numbers shown are for D, J, N, and W packages.



POST OFFICE BOX 655303 • DALLAS, TEXAS 75265

SN54174, SN54175, SN54LS174, SN54LS175, SN54S174, SN54S175,
 SN74174, SN74175, SN74LS174, SN74LS175, SN74S174, SN74S175
 HEX/QUADRUPLE D-TYPE FLIP-FLOPS WITH CLEAR

SDLS068A - DECEMBER 1972 - REVISED OCTOBER 2001

schematics of inputs and outputs

SN54174, SN54175, SN74174, SN74175

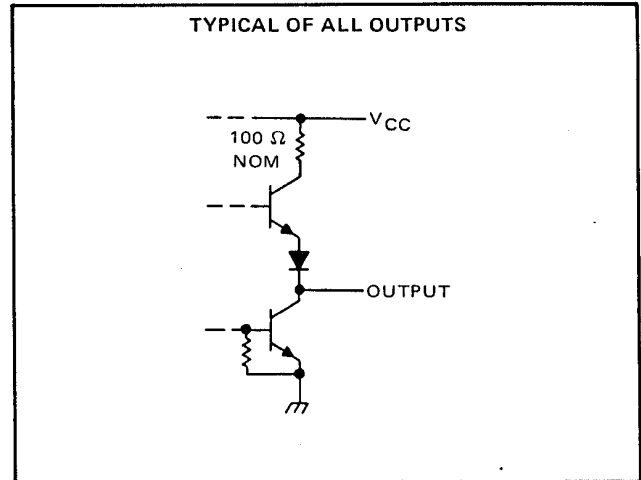
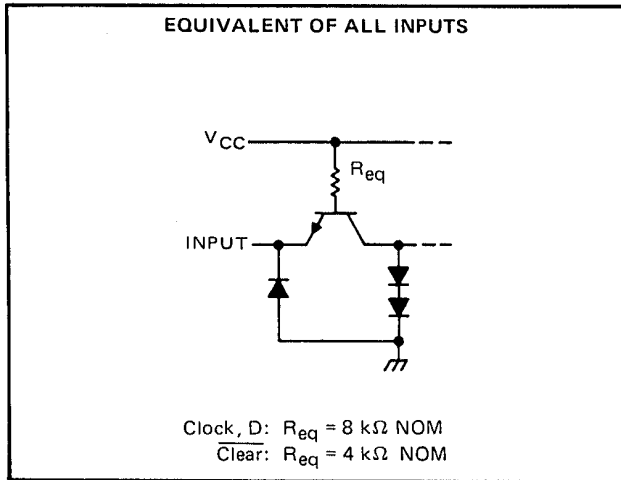

SN54LS174, SN54LS175, SN74LS174, SN74LS175

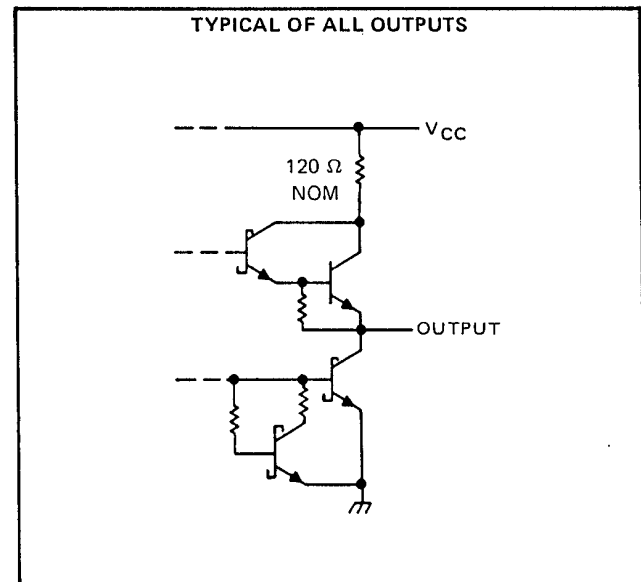
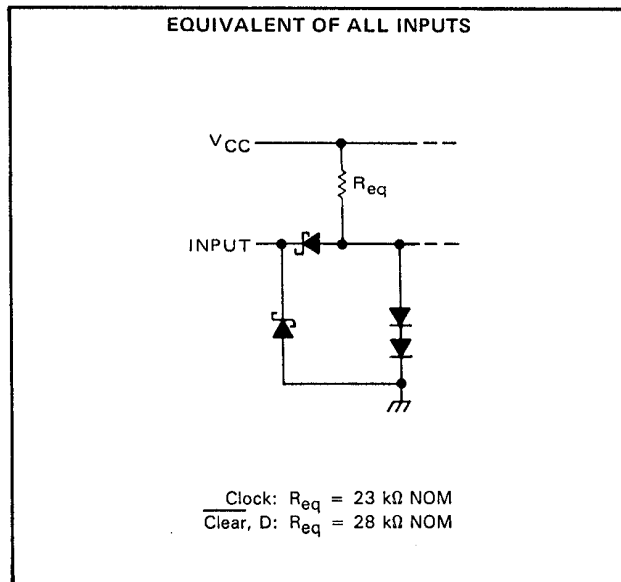

SN54S174, SN54S175, SN74S174, SN74S175

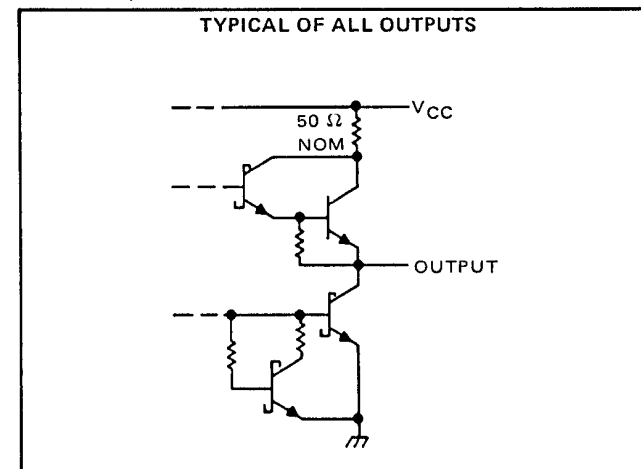
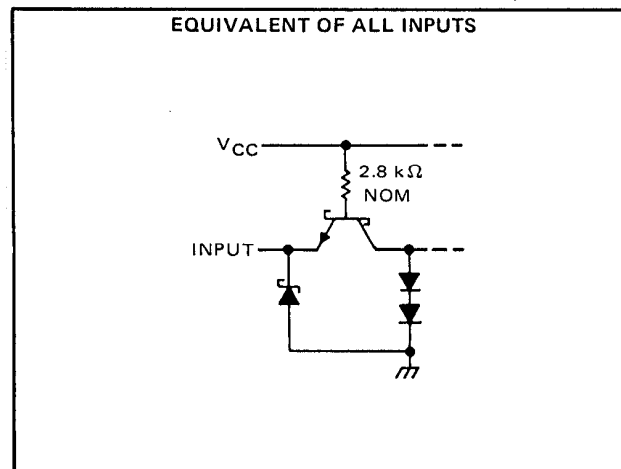

SN54174, SN54175, SN74174, SN74175 HEX/QUADRUPLE D-TYPE FLIP-FLOPS WITH CLEAR

SDLS068A – DECEMBER 1972 – REVISED OCTOBER 2001

absolute maximum ratings over operating free-air temperature range (unless otherwise noted)

Supply voltage, V_{CC} (see Note 1)	7 V
Input voltage	5.5 V
Operating free-air temperature range: SN54174, SN54175 Circuits	-55°C to 125°C
SN74174, SN74175 Circuits	0°C to 70°C
Storage temperature range	-65°C to 150°C

NOTE 1: Voltage values are with respect to network ground terminal.

recommended operating conditions

	SN54174, SN54175			SN74174, SN74175			UNIT		
	MIN	NOM	MAX	MIN	NOM	MAX			
Supply voltage, V_{CC}	4.5	5	5.5	4.75	5	5.25	V		
High-level output current, I_{OH}			-800			-800	μ A		
Low-level output current, I_{OL}			16			16	mA		
Clock frequency, f_{clock}	0		25	0		25	MHz		
Width of clock or clear pulse, t_w	20			20			ns		
Setup time, t_{su}	Data input			20			ns		
	Clear inactive-state			25			ns		
Data hold time, t_h	5			5			ns		
Operating free-air temperature, T_A	-55			125			0	70	°C

electrical characteristics over recommended operating free-air temperature range (unless otherwise noted)

PARAMETER	TEST CONDITIONS†	MIN	TYP‡	MAX	UNIT
V_{IH} High-level input voltage		2			V
V_{IL} Low-level input voltage				0.8	V
V_{IK} Input clamp voltage	$V_{CC} = \text{MIN}, I_I = -12 \text{ mA}$			-1.5	V
V_{OH} High-level output voltage	$V_{CC} = \text{MIN}, V_{IH} = 2 \text{ V}, V_{IL} = 0.8 \text{ V}, I_{OH} = -800 \mu\text{A}$	2.4	3.4		V
V_{OL} Low-level output voltage	$V_{CC} = \text{MIN}, V_{IH} = 2 \text{ V}, V_{IL} = 0.8 \text{ V}, I_{OL} = 16 \text{ mA}$		0.2	0.4	V
I_I Input current at maximum input voltage	$V_{CC} = \text{MAX}, V_I = 5.5 \text{ V}$			1	mA
I_{IH} High-level input current	$V_{CC} = \text{MAX}, V_I = 2.4 \text{ V}$			40	μ A
I_{IL} Low-level input current	$V_{CC} = \text{MAX}, V_I = 0.4 \text{ V}$			-1.6	mA
I_{OS} Short-circuit output current§	$V_{CC} = \text{MAX}$	SN54'	-20	-57	mA
		SN74'	-18	-57	
I_{CC} Supply current	$V_{CC} = \text{MAX},$ See Note 2	'174	45	65	mA
		'175	30	45	

† For conditions shown as MIN or MAX, use the appropriate value specified under recommended operating conditions for the applicable device type.

‡ All typical values are at $V_{CC} = 5 \text{ V}, T_A = 25^\circ\text{C}$.

§ Not more than one output should be shorted at a time.

NOTE 2: With all outputs open and 4.5 V applied to all data and clear inputs, I_{CC} is measured after a momentary ground, then 4.5 V, is applied to clock.

switching characteristics, $V_{CC} = 5 \text{ V}, T_A = 25^\circ\text{C}$

PARAMETER	TEST CONDITIONS	MIN	TYP	MAX	UNIT
f_{max} Maximum clock frequency		25	35		MHz
t_{PLH} Propagation delay time, low-to-high-level output from clear (SN54175, SN74175 only)	$C_L = 15 \text{ pF}, R_L = 400 \Omega,$ See Note 3		16	25	ns
t_{PHL} Propagation delay time, high-to-low-level output from clear			23	35	ns
t_{PLH} Propagation delay time, low-to-high-level output from clock			20	30	ns
t_{PHL} Propagation delay time, high-to-low-level output from clock			24	35	ns

NOTE 3: Load circuits and voltage waveforms are shown in Section 1.



SN54LS174, SN54LS175, SN74LS174, SN74LS175 HEX/QUADRUPLE D-TYPE FLIP-FLOPS WITH CLEAR

SDLS068A – DECEMBER 1972 – REVISED OCTOBER 2001

absolute maximum ratings over operating free-air temperature range (unless otherwise noted)

Supply voltage, V_{CC} (see Note 1)	7 V
Input voltage	7 V
Operating free-air temperature range: SN54LS174, SN54LS175 Circuits	–55°C to 125°C
SN74LS174, SN74LS175 Circuits	0°C to 70°C
Storage temperature range	–65°C to 150°C

NOTE 1: Voltage values are with respect to network ground terminal.

recommended operating conditions

	SN54LS174 SN54LS175			SN74LS174 SN74LS175			UNIT
	MIN	NOM	MAX	MIN	NOM	MAX	
Supply voltage, V_{CC}	4.5	5	5.5	4.75	5	5.25	V
High-level output current, I_{OH}			–400			–400	μ A
Low-level output current, I_{OL}			4			8	mA
Clock frequency, f_{clock}	0		30	0		30	MHz
Width of clock or clear pulse, t_W	20			20			ns
Setup time, t_{su}	Data input	20		20			ns
	Clear inactive-state	25		25			ns
Data hold time, t_h	5			5			ns
Operating free-air temperature, T_A	–55		125	0		70	°C

electrical characteristics over recommended operating free-air temperature range (unless otherwise noted)

PARAMETER	TEST CONDITIONS†	SN54LS174 SN54LS175			SN74LS174 SN74LS175			UNIT
		MIN	TYP‡	MAX	MIN	TYP‡	MAX	
V_{IH} High-level input voltage		2			2			V
V_{IL} Low-level input voltage				0.7			0.8	V
V_{IK} Input clamp voltage	$V_{CC} = \text{MIN}, I_I = -18 \text{ mA}$			–1.5			–1.5	V
V_{OH} High-level output voltage	$V_{CC} = \text{MIN}, V_{IH} = 2 \text{ V}, V_{IL} = V_{IL \text{ max}}, I_{OH} = -400 \mu\text{A}$	2.5	3.5		2.7	3.5		V
V_{OL} Low-level output voltage	$V_{CC} = \text{MIN}, V_{IH} = 2 \text{ V}, V_{IL} = V_{IL \text{ max}}$	$I_{OL} = 4 \text{ mA}$	0.25	0.4	0.25	0.4		V
		$I_{OL} = 8 \text{ mA}$			0.35	0.5		
I_I Input current at maximum input voltage	$V_{CC} = \text{MAX}, V_I = 7 \text{ V}$			0.1			0.1	mA
I_{IH} High-level input current	$V_{CC} = \text{MAX}, V_I = 2.7 \text{ V}$			20			20	μ A
I_{IL} Low-level input current	$V_{CC} = \text{MAX}, V_I = 0.4 \text{ V}$			–0.4			–0.4	mA
I_{OS} Short-circuit output current§	$V_{CC} = \text{MAX}$	–20		–100	–20		–100	mA
I_{CC} Supply current	$V_{CC} = \text{MAX},$ See Note 2	'LS174	16	26	16	26		mA
		'LS175	11	18	11	18		

† For conditions shown as MIN or MAX, use the appropriate value specified under recommended operating conditions.

‡ All typical values are at $V_{CC} = 5 \text{ V}, T_A = 25^\circ\text{C}$.

§ Not more than one output should be shorted at a time, and duration of the short-circuit should not exceed one second.

NOTE 2: With all outputs open and 4.5 V applied to all data and clear inputs, I_{CC} is measured after a momentary ground, then 4.5 V, is applied to clock.

switching characteristics, $V_{CC} = 5 \text{ V}, T_A = 25^\circ\text{C}$

PARAMETER	TEST CONDITIONS	'LS174			'LS175			UNIT
		MIN	TYP	MAX	MIN	TYP	MAX	
f_{max} Maximum clock frequency	$C_L = 15 \text{ pF},$ $R_L = 2 \text{ k}\Omega,$ See Note 3	30	40		30	40		MHz
t_{PLH} Propagation delay time, low-to-high-level output from clear					20	30		ns
t_{PHL} Propagation delay time, high-to-low-level output from clear			23	35	20	30		ns
t_{PLH} Propagation delay time, low-to-high-level output from clock			20	30	13	25		ns
t_{PHL} Propagation delay time, high-to-low-level output from clock			21	30	16	25		ns

NOTE 3: Load circuits and voltage waveforms are shown in Section 1.



SN54S174, SN54S175, SN74S174, SN74S175 HEX/QUADRUPLE D-TYPE FLIP-FLOPS WITH CLEAR

SDLS068A – DECEMBER 1972 – REVISED OCTOBER 2001

absolute maximum ratings over operating free-air temperature range (unless otherwise noted)

Supply voltage, V_{CC} (see Note 1)	7 V
Input voltage	5.5 V
Operating free-air temperature range: SN54S174, SN54S175 Circuits	-55°C to 125°C
SN74S174, SN74S175 Circuits	0°C to 70°C
Storage temperature range	-65°C to 150°C

NOTE 1: Voltage values are with respect to network ground terminal.

recommended operating conditions

	SN54S174, SN54S175			SN74S174, SN74S175			UNIT
	MIN	NOM	MAX	MIN	NOM	MAX	
Supply voltage, V_{CC}	4.5	5	5.5	4.75	5	5.25	V
High-level output current, I_{OH}			-1			-1	mA
Low-level output current, I_{OL}			20			20	mA
Clock frequency, f_{clock}	0		75	0		75	MHz
Pulse width, t_w	Clock		7			7	ns
	Clear		10			10	
Setup time, t_{su}	Data input		5			5	ns
	Clear inactive-state		5			5	
Data hold time, t_h			3			3	ns
Operating free-air temperature, T_A	-55		125	0		70	°C

electrical characteristics over recommended operating free-air temperature range (unless otherwise noted)

PARAMETER	TEST CONDITIONS†	MIN	TYP‡	MAX	UNIT
V_{IH} High-level input voltage		2			V
V_{IL} Low-level input voltage				0.8	V
V_{IK} Input clamp voltage	$V_{CC} = \text{MIN}, I_I = -18 \text{ mA}$			-1.2	V
V_{OH} High-level output voltage	$V_{CC} = \text{MIN}, V_{IH} = 2 \text{ V},$ $V_{IL} = 0.8 \text{ V}, I_{OH} = -1 \text{ mA}$	SN54S'	2.5	3.4	V
		SN74S'	2.7	3.4	
V_{OL} Low-level output voltage	$V_{CC} = \text{MIN}, V_{IH} = 2 \text{ V},$ $V_{IL} = 0.8 \text{ V}, I_{OL} = 20 \text{ mA}$			0.5	V
I_I Input current at maximum input voltage	$V_{CC} = \text{MAX}, V_I = 5.5 \text{ V}$			1	mA
I_{IH} High-level input current	$V_{CC} = \text{MAX}, V_I = 2.7 \text{ V}$			50	µA
I_{IL} Low-level input current	$V_{CC} = \text{MAX}, V_I = 0.5 \text{ V}$			-2	mA
I_{OS} Short-circuit output current §	$V_{CC} = \text{MAX}$	-40		-100	mA
I_{CC} Supply current	$V_{CC} = \text{MAX}, \text{ See Note 2}$	'174	90	144	mA
		'175	60	96	

† For conditions shown as MIN or MAX, use the appropriate value specified under recommended operating conditions for the applicable device type.

‡ All typical values are at $V_{CC} = 5 \text{ V}, T_A = 25^\circ\text{C}$.

§ Not more than one output should be shorted at a time, and duration of the short-circuit should not exceed one second.

NOTE 2: With all outputs open and 4.5 V applied to all data and clear inputs, I_{CC} is measured after a momentary ground, then 4.5 V, is applied to clock.

switching characteristics, $V_{CC} = 5 \text{ V}, T_A = 25^\circ\text{C}$

PARAMETER	TEST CONDITIONS	MIN	TYP	MAX	UNIT
f_{max} Maximum clock frequency		75	110		MHz
t_{PLH} Propagation delay time, low-to-high-level \bar{Q} output from clear (SN54S175, SN74S175 only)	$C_L = 15 \text{ pF},$ $R_L = 280 \Omega,$ See Note 3		10	15	ns
t_{PHL} Propagation delay time, high-to-low-level \bar{Q} output from clear			13	22	ns
t_{PLH} Propagation delay time, low-to-high-level output from clock			8	12	ns
t_{PHL} Propagation time, high-to-low-level output from clock			11.5	17	ns

NOTE 3: Load circuits and voltage waveforms are shown in Section 1.



IMPORTANT NOTICE

Texas Instruments Incorporated and its subsidiaries (TI) reserve the right to make corrections, modifications, enhancements, improvements, and other changes to its products and services at any time and to discontinue any product or service without notice. Customers should obtain the latest relevant information before placing orders and should verify that such information is current and complete. All products are sold subject to TI's terms and conditions of sale supplied at the time of order acknowledgment.

TI warrants performance of its hardware products to the specifications applicable at the time of sale in accordance with TI's standard warranty. Testing and other quality control techniques are used to the extent TI deems necessary to support this warranty. Except where mandated by government requirements, testing of all parameters of each product is not necessarily performed.

TI assumes no liability for applications assistance or customer product design. Customers are responsible for their products and applications using TI components. To minimize the risks associated with customer products and applications, customers should provide adequate design and operating safeguards.

TI does not warrant or represent that any license, either express or implied, is granted under any TI patent right, copyright, mask work right, or other TI intellectual property right relating to any combination, machine, or process in which TI products or services are used. Information published by TI regarding third-party products or services does not constitute a license from TI to use such products or services or a warranty or endorsement thereof. Use of such information may require a license from a third party under the patents or other intellectual property of the third party, or a license from TI under the patents or other intellectual property of TI.

Reproduction of information in TI data books or data sheets is permissible only if reproduction is without alteration and is accompanied by all associated warranties, conditions, limitations, and notices. Reproduction of this information with alteration is an unfair and deceptive business practice. TI is not responsible or liable for such altered documentation.

Resale of TI products or services with statements different from or beyond the parameters stated by TI for that product or service voids all express and any implied warranties for the associated TI product or service and is an unfair and deceptive business practice. TI is not responsible or liable for any such statements.

Mailing Address:

Texas Instruments
Post Office Box 655303
Dallas, Texas 75265

PRODUCT FOLDER | PRODUCT INFO: [FEATURES](#) | [DESCRIPTION](#) | [DATASHEETS](#) | [PRICING/AVAILABILITY/PKG](#) | [APPLICATION NOTES](#) | [RELATED DOCUMENTS](#)

PRODUCT SUPPORT: [TRAINING](#)

SN74LS174, Hex D-Type Flip-Flops With Clear

DEVICE STATUS: **ACTIVE**

PARAMETER NAME	SN54LS174	SN74LS174
Voltage Nodes (V)	5	5
Vcc range (V)	4.5 to 5.5	4.75 to 5.25
Input Level	TTL	TTL
Output Level	TTL	TTL
Output Drive (mA)		-0.4/8
Output	2S	2S
No. of Bits	6	6
Static Current		26
th (ns)		5
tpd max (ns)		30
tsu (ns)		20

FEATURES

[▲ Back to Top](#)

- '174, 'LS174, 'S174 Contain Six Flip-Flops with Single-Rail Outputs
- '175, 'LS175, 'S175 Contain Four Flip-Flops with Double-Rail Outputs
- Three Performance Ranges Offered: See Table Lower Right
- Buffered Clock and Direct Clear Inputs
- Individual Data Input to Each Flip-Flop
- Applications include:
 - Buffer/Storage Registers
 - Shift Registers
 - Pattern Generators

DESCRIPTION

[▲ Back to Top](#)

These monolithic, positive-edge-triggered flip-flops utilize TTL circuitry to implement D-type flip-flop logic. All have a direct clear input, and the '175, 'LS175, and 'S175 feature complementary outputs from each flip-flop.

Information at the D inputs meeting the setup time requirements is transferred to the Q outputs on the positive-going edge of the clock pulse. Clock triggering occurs at a particular voltage level and is not directly related to the transition time of the positive-going pulse. When the clock input is at either the high or low level, the D input signal has no effect at the output.

These circuits are fully compatible for use with most TTL circuits.

TECHNICAL DOCUMENTS

[▲ Back to Top](#)

To view the following documents, [Acrobat Reader 4.0](#) is required.

To download a document to your hard drive, right-click on the link and choose 'Save'.

DATASHEET

[▲Back to Top](#)

Full datasheet in Acrobat PDF: [sn74ls174.pdf](#) (318 KB,Rev.A) (Updated: 10/12/2001)

APPLICATION NOTES

[▲Back to Top](#)

View Application Notes for [Digital Logic](#)

- [Designing With Logic \(Rev. C\)](#) (SDYA009C - Updated: 06/01/1997)
- [Designing with the SN54/74LS123 \(Rev. A\)](#) (SDLA006A - Updated: 03/01/1997)
- [Evaluation of Nickel/Palladium/Gold-Finished Surface-Mount Integrated Circuits \(SZZA026\)](#) - Updated: 06/20/2001)
- [Input and Output Characteristics of Digital Integrated Circuits](#) (SDYA010 - Updated: 10/01/1996)
- [Live Insertion](#) (SDYA012 - Updated: 10/01/1996)

RELATED DOCUMENTS

[▲Back to Top](#)

View Related Documentation for [Digital Logic](#)

- [Logic Reference Guide](#) (SCYB004, 1032 KB - Updated: 10/23/2001)
- [Logic Selection Guide Second Half 2002 \(Rev. R\)](#) (SDYU001R, 4274 KB - Updated: 07/19/2002)
- [Military Semiconductors Selection Guide 2002 \(Rev. B\)](#) (SGYC003B, 1648 KB - Updated: 04/22/2002)

PRICING/AVAILABILITY/PKG

[▲Back to Top](#)

DEVICE INFORMATION							TI INVENTORY STATUS AS OF 3:00 PM GMT, 26 Sep 2002			REPORTED DISTRIBUTOR INVENTORY AS OF 3:00 PM GMT, 26 Sep 2002		
ORDERABLE DEVICE	STATUS	PACKAGE TYPE PINS	TEMP (°C)	PRODUCT CONTENT	BUDGETARY PRICING QTY SUS	STD PACK QTY	IN STOCK	IN PROGRESS QTY DATE	LEAD TIME	DISTRIBUTOR COMPANY REGION	IN STOCK	PURCHASE
SN74LS174D	ACTIVE	SOP (D) 16	0 TO 70	View Contents	1KU 0.34	40	560	> 10k 19 Sep	4 WKS	Avnet AMERICA	> 1k	BUY NOW
								1114 03 Oct				
								> 10k 10 Oct				
								> 10k 17 Oct				
SN74LS174DR	ACTIVE	SOP (D) 16	0 TO 70	View Contents	1KU 0.36	2500	7500	3614 03 Oct	4 WKS	Avnet AMERICA	> 1k	BUY NOW
								> 10k 10 Oct				
								> 10k 17 Oct				
SN74LS174J	OBSOLETE	CDIP (J) 16	0 TO 70	View Contents	1KU		N/A*		Not Available			
SN74LS174N	ACTIVE	PDIP (N) 16	0 TO 70	View Contents	1KU 0.27	25	N/A*	350 23 Sep	4 WKS	Avnet AMERICA	> 1k	BUY NOW
								1800 24 Sep		DigiKey AMERICA	789	BUY NOW
								2980 25 Sep				

								6935 02 Oct			
								> 10k 04 Oct			
SN74LS174N3	OBSOLETE	PDIP (N) 16	0 TO 70	View Contents	1KU			N/A*		Not Available	
SN74LS174NSR	ACTIVE	SOP (NS) 16		View Contents	1KU 0.27	2000		N/A*	> 10k 04 Oct	4 WKS	
									2302 11 Oct		
									> 10k 18 Oct		
									1500 19 Nov		
									500 21 Nov		

Table Data Updated on: 9/26/2002

PRODUCT FOLDER | PRODUCT INFO: [FEATURES](#) | [DESCRIPTION](#) | [DATASHEETS](#) | [PRICING/AVAILABILITY/PKG](#) | [APPLICATION NOTES](#) | [RELATED DOCUMENTS](#)

PRODUCT SUPPORT: [TRAINING](#)

SN74S174, Hex D-Type Flip-Flops With Clear

DEVICE STATUS: **ACTIVE**

PARAMETER NAME	SN54S174	SN74S174
Voltage Nodes (V)	5	5
Vcc range (V)	4.5 to 5.5	4.75 to 5.25
Input Level	TTL	TTL
Output Level	TTL	TTL
Output Drive (mA)		-1/20
Output	2S	2S
No. of Bits	6	6
Static Current		144
th (ns)		3
tpd max (ns)		17
tsu (ns)		5

FEATURES

[▲ Back to Top](#)

- '174, 'LS174, 'S174 Contain Six Flip-Flops with Single-Rail Outputs
- '175, 'LS175, 'S175 Contain Four Flip-Flops with Double-Rail Outputs
- Three Performance Ranges Offered: See Table Lower Right
- Buffered Clock and Direct Clear Inputs
- Individual Data Input to Each Flip-Flop
- Applications include:
 - Buffer/Storage Registers
 - Shift Registers
 - Pattern Generators

DESCRIPTION

[▲ Back to Top](#)

These monolithic, positive-edge-triggered flip-flops utilize TTL circuitry to implement D-type flip-flop logic. All have a direct clear input, and the '175, 'LS175, and 'S175 feature complementary outputs from each flip-flop.

Information at the D inputs meeting the setup time requirements is transferred to the Q outputs on the positive-going edge of the clock pulse. Clock triggering occurs at a particular voltage level and is not directly related to the transition time of the positive-going pulse. When the clock input is at either the high or low level, the D input signal has no effect at the output.

These circuits are fully compatible for use with most TTL circuits.

TECHNICAL DOCUMENTS

[▲ Back to Top](#)

To view the following documents, [Acrobat Reader 4.0](#) is required.

To download a document to your hard drive, right-click on the link and choose 'Save'.

DATASHEET

[▲Back to Top](#)

Full datasheet in Acrobat PDF: [sn74s174.pdf](#) (318 KB,Rev.A) (Updated: 10/12/2001)

APPLICATION NOTES

[▲Back to Top](#)

View Application Notes for [Digital Logic](#)

- [Designing With Logic \(Rev. C\)](#) (SDYA009C - Updated: 06/01/1997)
- [Evaluation of Nickel/Palladium/Gold-Finished Surface-Mount Integrated Circuits](#) (SZZA026 - Updated: 06/20/2001)
- [Input and Output Characteristics of Digital Integrated Circuits](#) (SDYA010 - Updated: 10/01/1996)
- [Live Insertion](#) (SDYA012 - Updated: 10/01/1996)

RELATED DOCUMENTS

[▲Back to Top](#)

View Related Documentation for [Digital Logic](#)

- [Logic Reference Guide](#) (SCYB004, 1032 KB - Updated: 10/23/2001)
- [Logic Selection Guide Second Half 2002 \(Rev. R\)](#) (SDYU001R, 4274 KB - Updated: 07/19/2002)
- [Military Semiconductors Selection Guide 2002 \(Rev. B\)](#) (SGYC003B, 1648 KB - Updated: 04/22/2002)

PRICING/AVAILABILITY/PKG

[▲Back to Top](#)

DEVICE INFORMATION							TI INVENTORY STATUS AS OF 3:00 PM GMT, 26 Sep 2002			REPORTED DISTRIBUTOR INVENTORY AS OF 3:00 PM GMT, 26 Sep 2002		
ORDERABLE DEVICE	STATUS	PACKAGE TYPE PINS	TEMP (°C)	PRODUCT CONTENT	BUDGETARY PRICING QTY \$US	STD PACK QTY	IN STOCK	IN PROGRESS QTY DATE	LEAD TIME	DISTRIBUTOR COMPANY REGION	IN STOCK	PURCHASE
SN74S174J	OBSOLETE	CDIP (J) 16	0 TO 70	View Contents	1KU		N/A*		Not Available			
SN74S174N	ACTIVE	PDIP (N) 16	0 TO 70	View Contents	1KU 0.59	25	N/A*	7949 04 Oct	5 WKS	Avnet AMERICA	> 1k	BUY NOW
								> 10k 11 Oct				
SN74S174N3	OBSOLETE	PDIP (N) 16	0 TO 70	View Contents	1KU		N/A*		Not Available			
SN74S174NSR	ACTIVE	SOP (NS) 16		View Contents	1KU 0.59	2000	N/A*	7909 04 Oct	5 WKS			
								2302 11 Oct				
								> 10k 18 Oct				

Table Data Updated on: 9/26/2002

PRODUCT FOLDER | PRODUCT INFO: [FEATURES](#) | [DESCRIPTION](#) | [DATASHEETS](#) | [PRICING/AVAILABILITY/PKG](#) | [APPLICATION NOTES](#) | [RELATED DOCUMENTS](#)

PRODUCT SUPPORT: [TRAINING](#)

SN74S175, Quadruple D-Type Flip-Flops With Clear

DEVICE STATUS: **ACTIVE**

PARAMETER NAME	SN54S175	SN74S175
Voltage Nodes (V)	5	5
Vcc range (V)	4.5 to 5.5	4.75 to 5.25
Input Level	TTL	TTL
Output Level	TTL	TTL
Output Drive (mA)		-1/20
Output	2S	2S
No. of Bits	4	4
Static Current		96
th (ns)		3
tpd max (ns)		17
tsu (ns)		5

FEATURES

[▲ Back to Top](#)

- '174, 'LS174, 'S174 Contain Six Flip-Flops with Single-Rail Outputs
- '175, 'LS175, 'S175 Contain Four Flip-Flops with Double-Rail Outputs
- Three Performance Ranges Offered: See Table Lower Right
- Buffered Clock and Direct Clear Inputs
- Individual Data Input to Each Flip-Flop
- Applications include:
 - Buffer/Storage Registers
 - Shift Registers
 - Pattern Generators

DESCRIPTION

[▲ Back to Top](#)

These monolithic, positive-edge-triggered flip-flops utilize TTL circuitry to implement D-type flip-flop logic. All have a direct clear input, and the '175, 'LS175, and 'S175 feature complementary outputs from each flip-flop.

Information at the D inputs meeting the setup time requirements is transferred to the Q outputs on the positive-going edge of the clock pulse. Clock triggering occurs at a particular voltage level and is not directly related to the transition time of the positive-going pulse. When the clock input is at either the high or low level, the D input signal has no effect at the output.

These circuits are fully compatible for use with most TTL circuits.

TECHNICAL DOCUMENTS

[▲ Back to Top](#)

To view the following documents, [Acrobat Reader 4.0](#) is required.

To download a document to your hard drive, right-click on the link and choose 'Save'.

DATASHEET

[▲Back to Top](#)

Full datasheet in Acrobat PDF: [sn74s175.pdf](#) (318 KB,Rev.A) (Updated: 10/12/2001)

APPLICATION NOTES

[▲Back to Top](#)

View Application Notes for [Digital Logic](#)

- [Designing With Logic \(Rev. C\)](#) (SDYA009C - Updated: 06/01/1997)
- [Evaluation of Nickel/Palladium/Gold-Finished Surface-Mount Integrated Circuits](#) (SZZA026 - Updated: 06/20/2001)
- [Input and Output Characteristics of Digital Integrated Circuits](#) (SDYA010 - Updated: 10/01/1996)
- [Live Insertion](#) (SDYA012 - Updated: 10/01/1996)

RELATED DOCUMENTS

[▲Back to Top](#)

View Related Documentation for [Digital Logic](#)

- [Logic Reference Guide](#) (SCYB004, 1032 KB - Updated: 10/23/2001)
- [Logic Selection Guide Second Half 2002 \(Rev. R\)](#) (SDYU001R, 4274 KB - Updated: 07/19/2002)
- [Military Semiconductors Selection Guide 2002 \(Rev. B\)](#) (SGYC003B, 1648 KB - Updated: 04/22/2002)

PRICING/AVAILABILITY/PKG

[▲Back to Top](#)

DEVICE INFORMATION							TI INVENTORY STATUS AS OF 3:00 PM GMT, 26 Sep 2002			REPORTED DISTRIBUTOR INVENTORY AS OF 3:00 PM GMT, 26 Sep 2002		
ORDERABLE DEVICE	STATUS	PACKAGE TYPE PINS	TEMP (°C)	PRODUCT CONTENT	BUDGETARY PRICING QTY \$US	STD PACK QTY	IN STOCK	IN PROGRESS QTY DATE	LEAD TIME	DISTRIBUTOR COMPANY REGION	IN STOCK	PURCHASE
SN74S175D	ACTIVE	SOP (D) 16	0 TO 70	View Contents	1KU 0.60	40	N/A*	1800 03 Oct	5 WKS			
								>10k 10 Oct				
SN74S175DR	OBSOLETE	SOP (D) 16	0 TO 70	View Contents	1KU		N/A*		Not Available			
SN74S175N	ACTIVE	PDIP (N) 16	0 TO 70	View Contents	1KU 0.59	25	N/A*	>10k 04 Oct	5 WKS	Avnet AMERICA	249	BUY NOW
								>10k 11 Oct				
SN74S175N3	OBSOLETE	PDIP (N) 16	0 TO 70	View Contents	1KU		N/A*		Not Available			
SN74S175NSR	ACTIVE	SOP (NS) 16		View Contents	1KU 0.59	2000	N/A*	>10k 04 Oct	5 WKS			
								2302 11 Oct				
								>10k 18 Oct				

Table Data Updated on: 9/26/2002

