

# TCA6408 Low-Voltage 8-BIT I<sup>2</sup>C and SMBus I/O Expander With Interrupt Output, Reset, and Configuration Registers

*Not Recommended for New Designs*

## 1 Features

- Operating Power-Supply Voltage Range of 1.65 V to 5.5 V
- Allows Bidirectional Voltage-Level Translation and GPIO Expansion Between
  - 1.8-V SCL/SDA and 1.8-V, 2.5-V, 3.3-V, or 5-V P Port
  - 2.5-V SCL/SDA and 1.8-V, 2.5-V, 3.3-V, or 5-V P Port
  - 3.3-V SCL/SDA and 1.8-V, 2.5-V, 3.3-V, or 5-V P Port
  - 5-V SCL/SDA and 1.8-V, 2.5-V, 3.3-V, or 5-V P Port
- I<sup>2</sup>C to Parallel Port Expander
- Low Standby Current Consumption of 1  $\mu$ A
- Schmitt-Trigger Action Allows Slow Input Transition and Better Switching Noise Immunity at the SCL and SDA Inputs
  - $V_{hys} = 0.18$  V Typ at 1.8 V
  - $V_{hys} = 0.25$  V Typ at 2.5 V
  - $V_{hys} = 0.33$  V Typ at 3.3 V
  - $V_{hys} = 0.5$  V Typ at 5 V
- 5-V Tolerant I/O Ports
- Active-Low Reset ( $\overline{\text{RESET}}$ ) Input
- Open-Drain Active-Low Interrupt ( $\overline{\text{INT}}$ ) Output
- 400-kHz Fast I<sup>2</sup>C Bus
- Input/Output Configuration Register
- Polarity Inversion Register
- Internal Power-On Reset
- Power Up With All Channels Configured as Inputs
- No Glitch On Power Up

- Noise Filter on SCL/SDA Inputs
- Latched Outputs With High-Current Drive Maximum Capability for Directly Driving LEDs
- Latch-Up Performance Exceeds 100 mA Per JESD 78, Class II
- ESD Protection Exceeds JESD 22
  - 2000-V Human-Body Model (A114-A)
  - 200-V Machine Model (A115-A)
  - 1000-V Charged-Device Model (C101)

## 2 Description

This 8-bit I/O expander for the two-line bidirectional bus (I<sup>2</sup>C) is designed to provide general-purpose remote I/O expansion for most microcontroller families via the I<sup>2</sup>C interface [serial clock (SCL) and serial data (SDA)].

The major benefit of this device is its wide  $V_{CC}$  range. It can operate from 1.65-V to 5.5-V on the P-port side and on the SDA/SCL side. This allows the TCA6408 to interface with next-generation microprocessors and microcontrollers on the SDA/SCL side, where supply levels are dropping down to conserve power. In contrast to the dropping power supplies of microprocessors and microcontrollers, some PCB components such as LEDs remain at a 5-V power supply.

### Device Information<sup>(1)</sup>

PART NUMBER	PACKAGE	BODY SIZE (NOM)
TCA6408	TSSOP (16)	5.00 mm x 4.40 mm
	QFN (16)	3.00 mm x 3.00 mm
	BGA (20)	2.50 mm x 3.00 mm

(1) For all available packages, see the orderable addendum at the end of the datasheet.

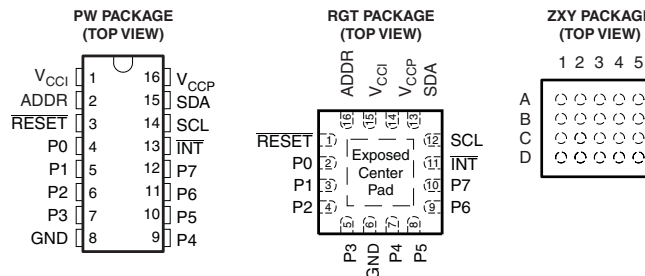

If used, the exposed center pad must be connected as a secondary ground or left electrically open.



## Table of Contents

<b>1 Features</b> .....	<b>1</b>	6.8 Typical Characteristics .....	<b>8</b>
<b>2 Description</b> .....	<b>1</b>	<b>7 Parameter Measurement Information</b> .....	<b>11</b>
<b>3 Revision History</b> .....	<b>2</b>	<b>8 Detailed Description</b> .....	<b>15</b>
<b>4 Description (Continued)</b> .....	<b>3</b>	8.1 Functional Block Diagram .....	<b>15</b>
<b>5 Pin Configuration and Functions</b> .....	<b>4</b>	8.2 Device Functional Modes .....	<b>17</b>
<b>6 Specifications</b> .....	<b>5</b>	8.3 Programming .....	<b>19</b>
6.1 Absolute Maximum Ratings .....	<b>5</b>	<b>9 Application And Implementation</b> .....	<b>25</b>
6.2 Handling Ratings .....	<b>5</b>	9.1 Typical Application .....	<b>25</b>
6.3 Recommended Operating Conditions .....	<b>5</b>	<b>10 Device and Documentation Support</b> .....	<b>27</b>
6.4 Electrical Characteristics .....	<b>6</b>	10.1 Trademarks .....	<b>27</b>
6.5 I <sup>2</sup> C Interface Timing Requirements .....	<b>7</b>	10.2 Electrostatic Discharge Caution .....	<b>27</b>
6.6 Reset Timing Requirements .....	<b>7</b>	10.3 Glossary .....	<b>27</b>
6.7 Switching Characteristics .....	<b>7</b>	<b>11 Mechanical, Packaging, and Orderable Information</b> .....	<b>27</b>

## 3 Revision History

Changes from Revision C (June 2007) to Revision D	Page
• Added <u>RESET</u> Errata section .....	<b>17</b>
• Added Interrupt Errata section .....	<b>18</b>

## 4 Description (Continued)

The bidirectional voltage-level translation in the TCA6408 is provided through  $V_{CC1}$ .  $V_{CC1}$  should be connected to the  $V_{CC}$  of the external SCL/SDA lines. This indicates the  $V_{CC}$  level of the I<sup>2</sup>C bus to the TCA6408. The voltage level on the P port of the TCA6408 is determined by  $V_{CCP}$ .

The TCA6408 consists of one 8-bit Configuration (input or output selection), Input, Output, and Polarity Inversion (active high) Register. At power on, the I/Os are configured as inputs. However, the system master can enable the I/Os as either inputs or outputs by writing to the I/O configuration bits. The data for each input or output is kept in the corresponding Input or Output Register. The polarity of the Input Port Register can be inverted with the Polarity Inversion Register. All registers can be read by the system master.

The system master can reset the TCA6408 in the event of a timeout or other improper operation by asserting a low in the  $\overline{\text{RESET}}$  input. The power-on reset puts the registers in their default state and initializes the I<sup>2</sup>C/SMBus state machine. The  $\overline{\text{RESET}}$  pin causes the same reset/initialization to occur without depowering the part.

The TCA6408 open-drain interrupt ( $\overline{\text{INT}}$ ) output is activated when any input state differs from its corresponding Input Port Register state and is used to indicate to the system master that an input state has changed.

$\overline{\text{INT}}$  can be connected to the interrupt input of a microcontroller. By sending an interrupt signal on this line, the remote I/O can inform the microcontroller if there is incoming data on its ports without having to communicate via the I<sup>2</sup>C bus. Thus, the TCA6408 can remain a simple slave device.

The device P-port outputs have high-current sink capabilities for directly driving LEDs while consuming low device current.

One hardware pin (ADDR) can be used to program and vary the fixed I<sup>2</sup>C address and allow up to two devices to share the same I<sup>2</sup>C bus or SMBus.

## 5 Pin Configuration and Functions

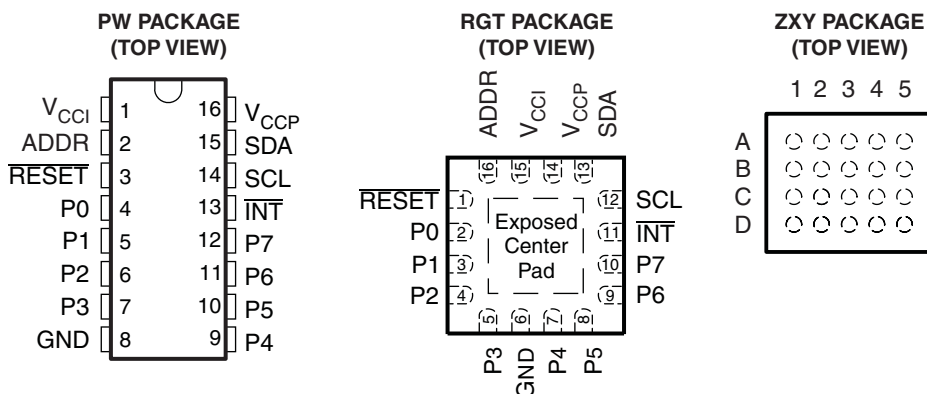

If used, the exposed center pad must be connected as a secondary ground or left electrically open.

### Pin Functions

PIN				DESCRIPTION
NAME	TSSOP (PW)	QFN (RGT)	BGA (ZXY)	
V <sub>CC1</sub>	1	15	B5	Supply voltage of I <sup>2</sup> C bus. Connect directly to the V <sub>CC</sub> of the external I <sup>2</sup> C master. Provides voltage level translation.
ADDR	2	16	A5	Address input. Connect directly to V <sub>CCP</sub> or ground.
RESET	3	1	A4	Active-low reset input. Connect to V <sub>CCP</sub> through a pullup resistor, if no active connection is used.
P0	4	2	B3	P-port input/output (push-pull design structure). At power on, P0 is configured as an input.
P1	5	3	A3	P-port input/output (push-pull design structure). At power on, P1 is configured as an input.
P2	6	4	A2	P-port input/output (push-pull design structure). At power on, P2 is configured as an input.
P3	7	5	A1	P-port input/output (push-pull design structure). At power on, P3 is configured as an input.
GND	8	6	B1	Ground
P4	9	7	C1	P-port input/output (push-pull design structure). At power on, P4 is configured as an input.
P5	10	8	D1	P-port input/output (push-pull design structure). At power on, P5 is configured as an input.
P6	11	9	D2	P-port input/output (push-pull design structure). At power on, P6 is configured as an input.
P7	12	10	D3	P-port input/output (push-pull design structure). At power on, P7 is configured as an input.
INT	13	11	C3	Interrupt output. Connect to V <sub>CC1</sub> through a pullup resistor.
SCL	14	12	D4	Serial clock bus. Connect to V <sub>CC1</sub> through a pullup resistor.
SDA	15	13	D5	Serial data bus. Connect to V <sub>CC1</sub> through a pullup resistor.
V <sub>CCP</sub>	16	14	C5	Supply voltage of TCA6408 for P port.
N.C.	–	–	B2, C2, B4, C4	No internal connection

## 6 Specifications

### 6.1 Absolute Maximum Ratings<sup>(1)</sup>

over operating free-air temperature range (unless otherwise noted)

				MIN	MAX	UNIT	
V <sub>CCI</sub>	Supply voltage range			-0.5	6.5	V	
V <sub>CCP</sub>	Supply voltage range			-0.5	6.5	V	
V <sub>I</sub>	Input voltage range <sup>(2)</sup>			-0.5	6.5	V	
V <sub>O</sub>	Output voltage range <sup>(2)</sup>			-0.5	6.5	V	
I <sub>IK</sub>	Input clamp current	ADDR, $\overline{\text{RESET}}$ , SCL	V <sub>I</sub> < 0		±20	mA	
I <sub>OK</sub>	Output clamp current	$\overline{\text{INT}}$	V <sub>O</sub> < 0		±20	mA	
I <sub>IOK</sub>	Input/output clamp current	P Port	V <sub>O</sub> < 0 or V <sub>O</sub> > V <sub>CCP</sub>		±20	mA	
		SDA	V <sub>O</sub> < 0 or V <sub>O</sub> > V <sub>CCI</sub>		±20		
I <sub>OL</sub>	Continuous output low current	P Port	V <sub>O</sub> = 0 to V <sub>CCP</sub>		50	mA	
	Continuous output low current	SDA, $\overline{\text{INT}}$	V <sub>O</sub> = 0 to V <sub>CCI</sub>		25		
I <sub>OH</sub>	Continuous output high current	P Port	V <sub>O</sub> = 0 to V <sub>CCP</sub>		50	mA	
I <sub>CC</sub>	Continuous current through GND				200	mA	
	Continuous current through V <sub>CCP</sub>				160		
	Continuous current through V <sub>CCI</sub>				10		
θ <sub>JA</sub>	Package thermal impedance <sup>(3)</sup>			PW package		108	°C/W
				RGT package		53	
				ZXY package		193	

- (1) Stresses beyond those listed under “absolute maximum ratings” may cause permanent damage to the device. These are stress ratings only, and functional operation of the device at these or any other conditions beyond those indicated under “recommended operating conditions” is not implied. Exposure to absolute-maximum-rated conditions for extended periods may affect device reliability.
- (2) The input negative-voltage and output voltage ratings may be exceeded if the input and output current ratings are observed.
- (3) The package thermal impedance is calculated in accordance with JESD 51-7.

### 6.2 Handling Ratings

				MIN	MAX	UNIT
T <sub>stg</sub>	Storage temperature range			-65	150	°C
V <sub>(ESD)</sub>	Electrostatic discharge	Human body model (HBM), per ANSI/ESDA/JEDEC JS-001, all pins <sup>(1)</sup>		0	2000	V
		Charged device model (CDM), per JEDEC specification JESD22-C101, all pins <sup>(2)</sup>		0	1000	

- (1) JEDEC document JEP155 states that 500-V HBM allows safe manufacturing with a standard ESD control process.
- (2) JEDEC document JEP157 states that 250-V CDM allows safe manufacturing with a standard ESD control process.

### 6.3 Recommended Operating Conditions

				MIN	MAX	UNIT
V <sub>CCI</sub>	Supply voltage			1.65	5.5	V
V <sub>CCP</sub>	Supply voltage			1.65	5.5	V
V <sub>IH</sub>	High-level input voltage	SCL, SDA		0.7 × V <sub>CCI</sub>	5.5	V
		ADDR, P7–P0, $\overline{\text{RESET}}$		0.7 × V <sub>CCP</sub>	5.5	
V <sub>IL</sub>	Low-level input voltage	SCL, SDA		-0.5	0.3 × V <sub>CCI</sub>	V
		ADDR, P7–P0, $\overline{\text{RESET}}$		-0.5	0.3 × V <sub>CCP</sub>	
I <sub>OH</sub>	High-level output current	P7–P0			10	mA
I <sub>OL</sub>	Low-level output current	P7–P0			25	mA
T <sub>A</sub>	Operating free-air temperature			-40	85	°C

TCA6408

SCPS151D – FEBRUARY 2007 – REVISED JUNE 2014

www.ti.com

### 6.4 Electrical Characteristics

over recommended operating free-air temperature range,  $V_{CCI} = 1.65\text{ V to }5.5\text{ V}$  (unless otherwise noted)

PARAMETER		TEST CONDITIONS	$V_{CCP}$	MIN	TYP <sup>(1)</sup>	MAX	UNIT
$V_{IK}$	Input diode clamp voltage	$I_I = -18\text{ mA}$	1.65 V to 5.5 V	-1.2			V
$V_{POR}$	Power-on reset voltage <sup>(2)</sup>	$V_I = V_{CCP}$ or GND, $I_O = 0$	1.65 V to 5.5 V		1	1.4	V
$V_{OH}$	P-port high-level output voltage	$I_{OH} = -8\text{ mA}$	1.65 V	1.2			V
			2.3 V	1.8			
			3 V	2.6			
			4.5 V	4.1			
		$I_{OH} = -10\text{ mA}$	1.65 V	1.1			
			2.3 V	1.7			
			3 V	2.5			
			4.5 V	4.0			
$V_{OL}$	P-port low-level output voltage	$I_{OL} = 8\text{ mA}$	1.65 V			0.45	V
			2.3 V			0.25	
			3 V			0.25	
			4.5 V			0.2	
		$I_{OL} = 10\text{ mA}$	1.65 V			0.6	
			2.3 V			0.3	
			3 V			0.25	
			4.5 V			0.2	
$I_{OL}$	SDA	$V_{OL} = 0.4\text{ V}$	1.65 V to 5.5 V	3			mA
	$\overline{INT}$			3	15		
$I_I$	SCL, SDA	$V_I = V_{CCI}$ or GND	1.65 V to 5.5 V			$\pm 0.1$	$\mu\text{A}$
	ADDR, $\overline{\text{RESET}}$	$V_I = V_{CCP}$ or GND				$\pm 0.1$	
$I_{IH}$	P port	$V_I = V_{CCP}$	1.65 V to 5.5 V			1	$\mu\text{A}$
$I_{IL}$	P port	$V_I = \text{GND}$				1	$\mu\text{A}$
$I_{CC}$ ( $I_{CCI} + I_{CCP}$ )	Operating mode	SDA, P port, ADDR, $\overline{\text{RESET}}$	$V_I$ on SDA = $V_{CCI}$ or GND, $V_I$ on P port, ADDR and $\overline{\text{RESET}} = V_{CCP}$ or GND, $I_O = 0$ , I/O = inputs, $f_{SCL} = 400\text{ kHz}$	3.6 V to 5.5 V	10	20	$\mu\text{A}$
			2.3 V to 3.6 V	6.5	15		
			1.65 V to 2.3 V	4	9		
			$V_I$ on SDA = $V_{CCI}$ or GND, $V_I$ on P port, ADDR and $\overline{\text{RESET}} = V_{CCP}$ or GND, $I_O = 0$ , I/O = inputs, $f_{SCL} = 100\text{ kHz}$	3.6 V to 5.5 V	2.5	5	
			2.3 V to 3.6 V	1.6	3.8		
			1.65 V to 2.3 V	1	2.3		
	Standby mode	SCL, SDA, P port, ADDR, $\overline{\text{RESET}}$	$V_I$ on SCL and SDA = $V_{CCI}$ or GND, $V_I$ on P Port, ADDR and $\overline{\text{RESET}} = V_{CCP}$ or GND, $I_O = 0$ , I/O = inputs, $f_{SCL} = 0$	3.6 V to 5.5 V	0.2	1	
			2.3 V to 3.6 V	0.1	0.6		
			1.65 V to 2.3 V	0.1	0.4		
$\Delta I_{CCI}$	Additional current in standby mode	SCL, SDA	One input at $V_{CCI} - 0.6\text{ V}$ , Other inputs at $V_{CCI}$ or GND	1.65 V to 5.5 V		25	$\mu\text{A}$
$\Delta I_{CCP}$		P port, ADDR, $\overline{\text{RESET}}$	One input at $V_{CCP} - 0.6\text{ V}$ , Other inputs at $V_{CCP}$ or GND	1.65 V to 5.5 V		60	$\mu\text{A}$
$C_i$	SCL		$V_I = V_{CCI}$ or GND	1.65 V to 5.5 V	6	7	pF
$C_{iO}$	SDA		$V_{IO} = V_{CCI}$ or GND	1.65 V to 5.5 V	7	8	pF
	P port		$V_{IO} = V_{CCP}$ or GND		7.5	8.5	

(1) All typical values are at nominal supply voltage (1.8-V, 2.5-V, 3.3-V, or 5-V  $V_{CC}$ ) and  $T_A = 25^\circ\text{C}$ .

(2) When power (from 0 V) is applied to  $V_{CCP}$ , an internal power-on reset holds the TCA6408 in a reset condition until  $V_{CCP}$  has reached  $V_{POR}$ . At that time, the reset condition is released, and the TCA6408 registers and I<sup>2</sup>C/SMBus state machine initialize to their default states. After that,  $V_{CCP}$  must be lowered to below 0.2 V and back up to the operating voltage for a power-reset cycle.

## 6.5 I<sup>2</sup>C Interface Timing Requirements

over recommended operating free-air temperature range (unless otherwise noted) (see Figure 14)

		STANDARD MODE I <sup>2</sup> C BUS		FAST MODE I <sup>2</sup> C BUS		UNIT
		MIN	MAX	MIN	MAX	
t <sub>scl</sub>	I <sup>2</sup> C clock frequency	0	100	0	400	kHz
t <sub>sch</sub>	I <sup>2</sup> C clock high time	4		0.6		μs
t <sub>scl</sub>	I <sup>2</sup> C clock low time	4.7		1.3		μs
t <sub>sp</sub>	I <sup>2</sup> C spike time	0	50	0	50	ns
t <sub>sds</sub>	I <sup>2</sup> C serial data setup time	250		100		ns
t <sub>sdh</sub>	I <sup>2</sup> C serial data hold time	0		0		ns
t <sub>icr</sub>	I <sup>2</sup> C input rise time		1000	20 + 0.1C <sub>b</sub> <sup>(1)</sup>	300	ns
t <sub>icf</sub>	I <sup>2</sup> C input fall time		300	20 + 0.1C <sub>b</sub> <sup>(1)</sup>	300	ns
t <sub>ocf</sub>	I <sup>2</sup> C output fall time, 10-pF to 400-pF bus		300	20 + 0.1C <sub>b</sub> <sup>(1)</sup>	300	μs
t <sub>buf</sub>	I <sup>2</sup> C bus free time between Stop and Start	4.7		1.3		μs
t <sub>sts</sub>	I <sup>2</sup> C Start or repeater Start condition setup time	4.7		0.6		μs
t <sub>sth</sub>	I <sup>2</sup> C Start or repeater Start condition hold time	4		0.6		μs
t <sub>sps</sub>	I <sup>2</sup> C Stop condition setup time	4		0.6		μs
t <sub>vd(data)</sub>	Valid data time, SCL low to SDA output valid		1		1	μs
t <sub>vd(ack)</sub>	Valid data time of ACK condition, ACK signal from SCL low to SDA (out) low		1		1	μs

 (1) C<sub>b</sub> = total capacitance of one bus line in pF

## 6.6 Reset Timing Requirements

over recommended operating free-air temperature range (unless otherwise noted) (see Figure 17)

		STANDARD MODE I <sup>2</sup> C BUS		FAST MODE I <sup>2</sup> C BUS		UNIT
		MIN	MAX	MIN	MAX	
t <sub>w</sub>	Reset pulse duration	4		4		ns
t <sub>REC</sub>	Reset recovery time	0		0		ns
t <sub>RESET</sub>	Time to reset <sup>(1)</sup>	600		600		ns

(1) Minimum time for SDA to become high or minimum time to wait before doing a Start

## 6.7 Switching Characteristics

 over recommended operating free-air temperature range, C<sub>L</sub> ≤ 100 pF (unless otherwise noted) (see Figure 14)

PARAMETER	FROM (INPUT)	TO (OUTPUT)	STANDARD MODE I <sup>2</sup> C BUS		FAST MODE I <sup>2</sup> C BUS		UNIT
			MIN	MAX	MIN	MAX	
t <sub>iv</sub>	Interrupt valid time	P Port		4		4	μs
t <sub>ir</sub>	Interrupt reset delay time	SCL		4		4	μs
t <sub>pV</sub>	Output data valid	SCL		400		400	ns
t <sub>ps</sub>	Input data setup time	P Port	0		0		ns
t <sub>ph</sub>	Input data hold time	P Port	300		300		ns

### 6.8 Typical Characteristics

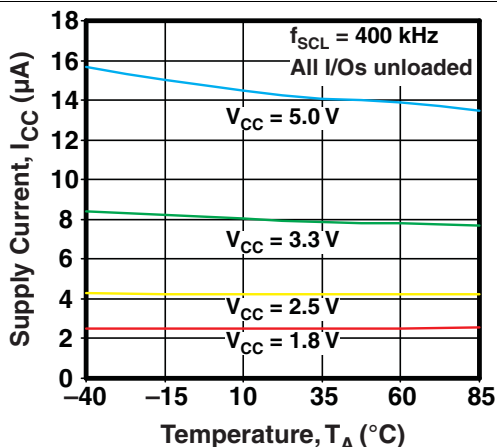

Figure 1. Supply Current vs Temperature

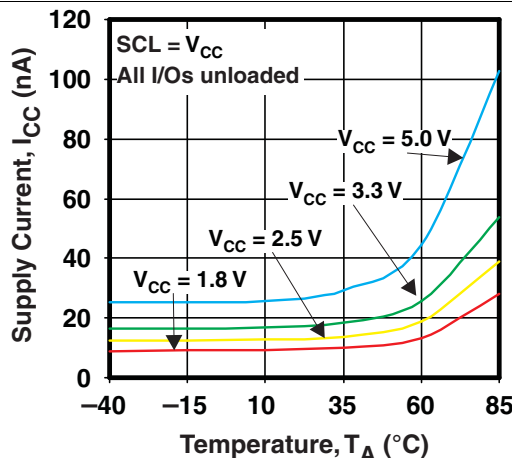

Figure 2. Standby Supply Current vs Temperature

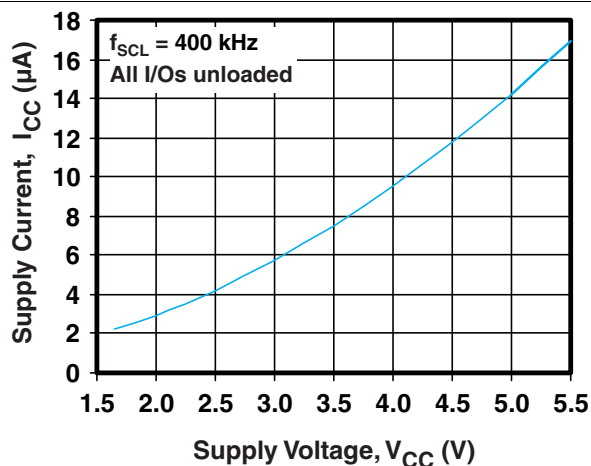

Figure 3. Supply Current vs Supply Voltage

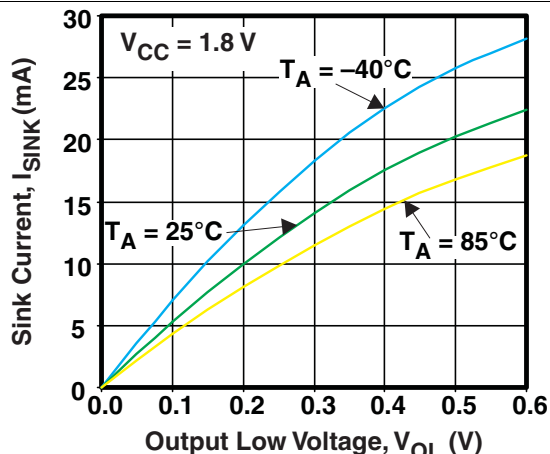

Figure 4. I/O Sink Current vs Output Low Voltage

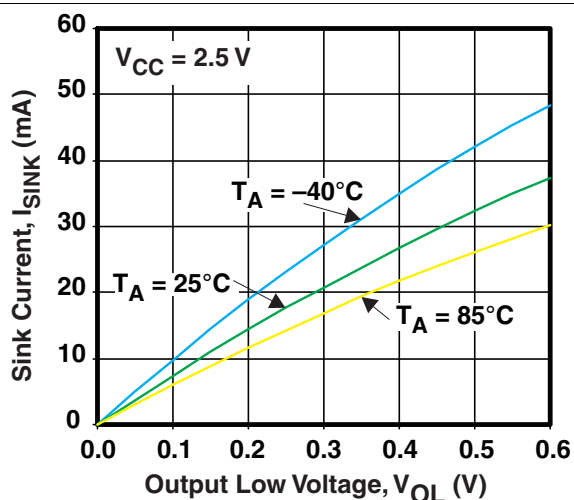

Figure 5. I/O Sink Current vs Output Low Voltage

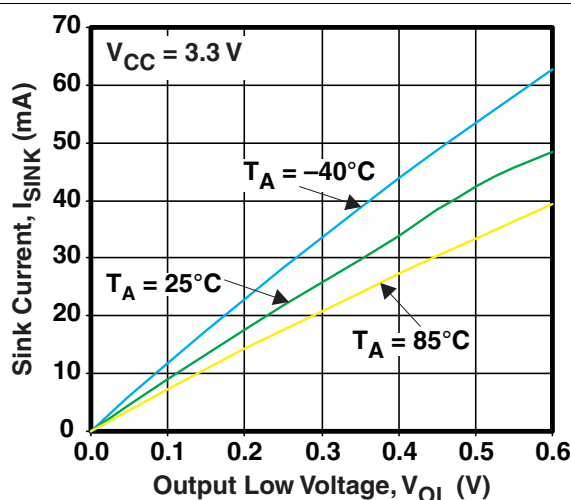

Figure 6. I/O Sink Current vs Output Low Voltage



Typical Characteristics (continued)

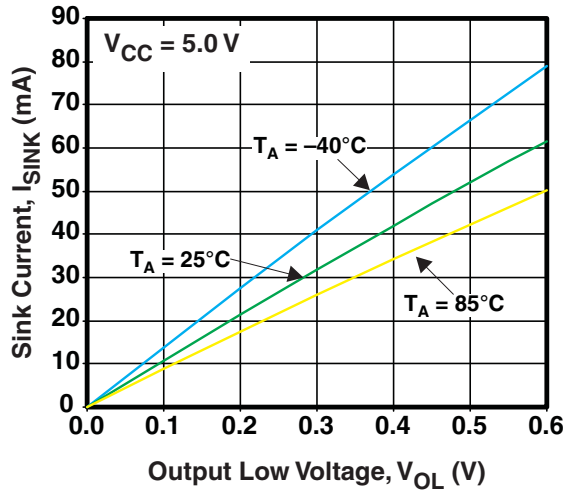

Figure 7. I/O Sink Current vs Output Low Voltage

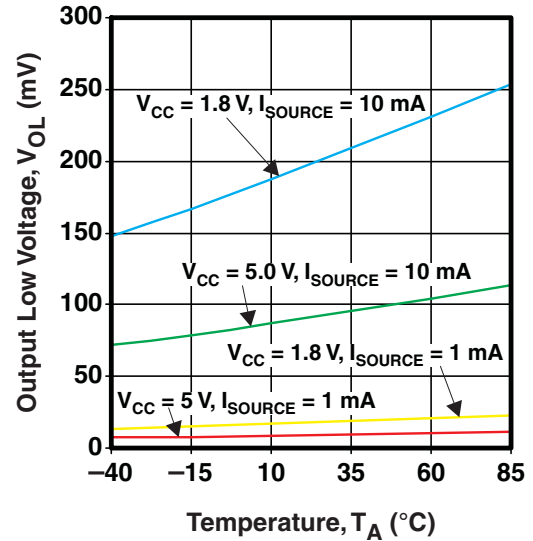

Figure 8. I/O Low Voltage vs Temperature

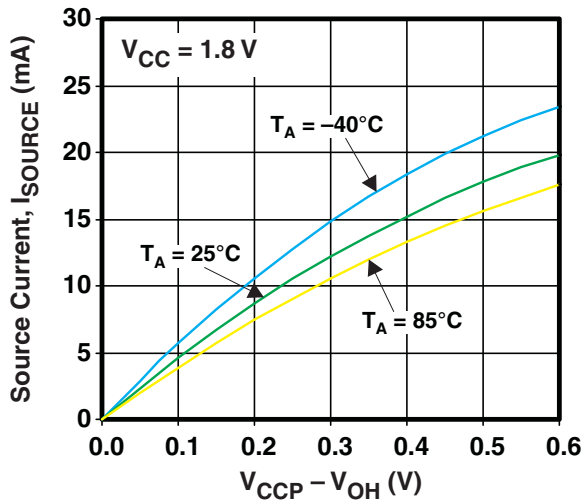

Figure 9. I/O Source Current vs Output High Voltage

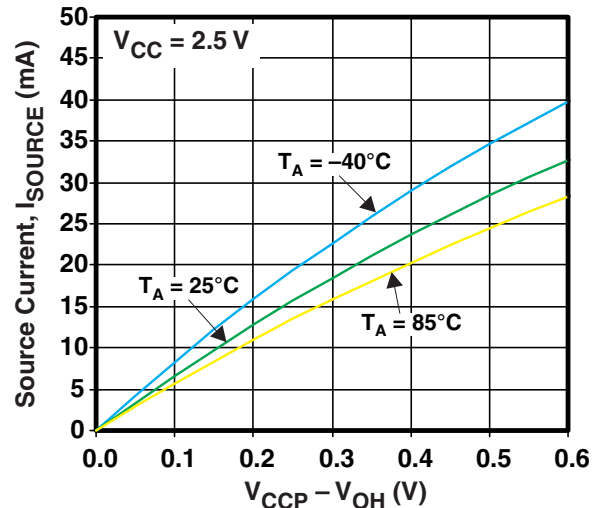

Figure 10. I/O Source Current vs Output High Voltage

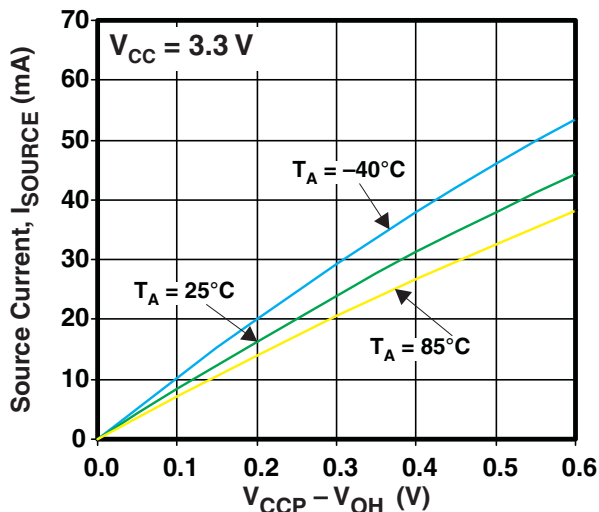

Figure 11. I/O Source Current vs Output High Voltage

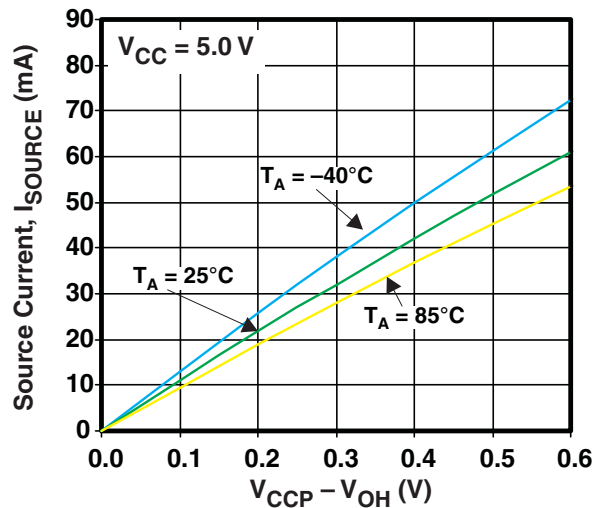

Figure 12. I/O Source Current vs Output High Voltage

Typical Characteristics (continued)

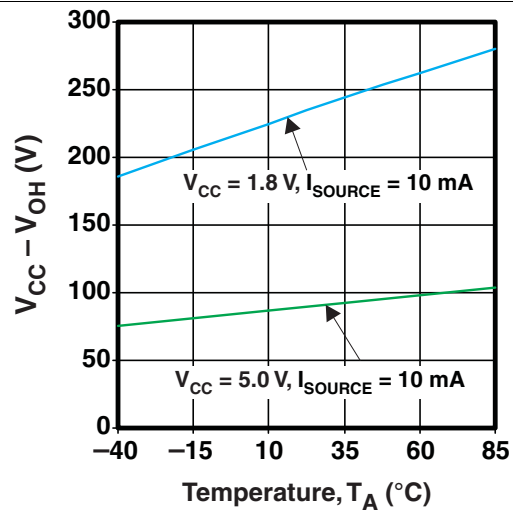
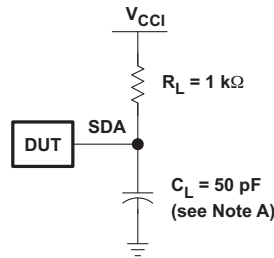
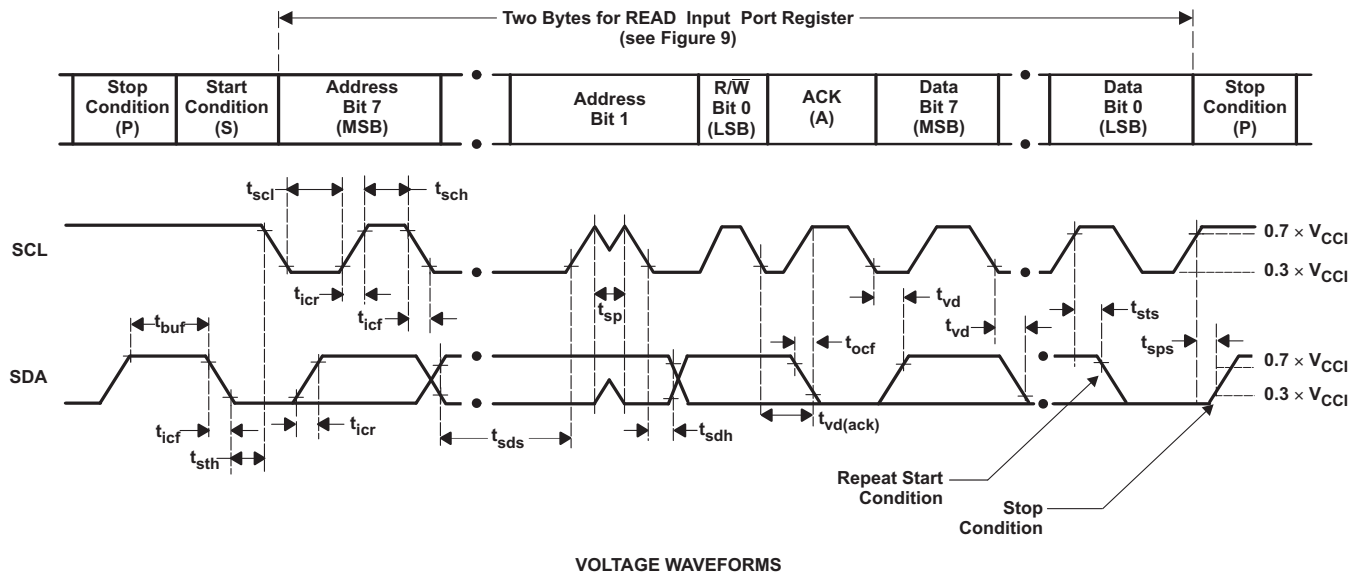

Figure 13. I/O High Voltage vs Temperature

## 7 Parameter Measurement Information



SDA LOAD CONFIGURATION



VOLTAGE WAVEFORMS

BYTE	DESCRIPTION
1	I <sup>2</sup> C address
2	Input register port data

- A.  $C_L$  includes probe and jig capacitance.  $t_{ocf}$  is measured with  $C_L$  of 10 pF or 400 pF.
- B. All inputs are supplied by generators having the following characteristics:  $PRR \leq 10$  MHz,  $Z_O = 50 \Omega$ ,  $t_r/t_f \leq 30$  ns.
- C. All parameters and waveforms are not applicable to all devices.

Figure 14. I<sup>2</sup>C Interface Load Circuit And Voltage Waveforms

Parameter Measurement Information (continued)

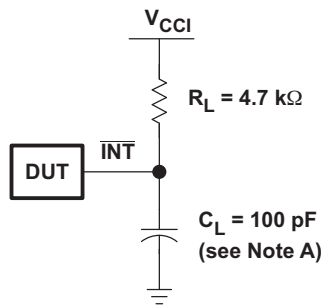

INTERRUPT LOAD CONFIGURATION

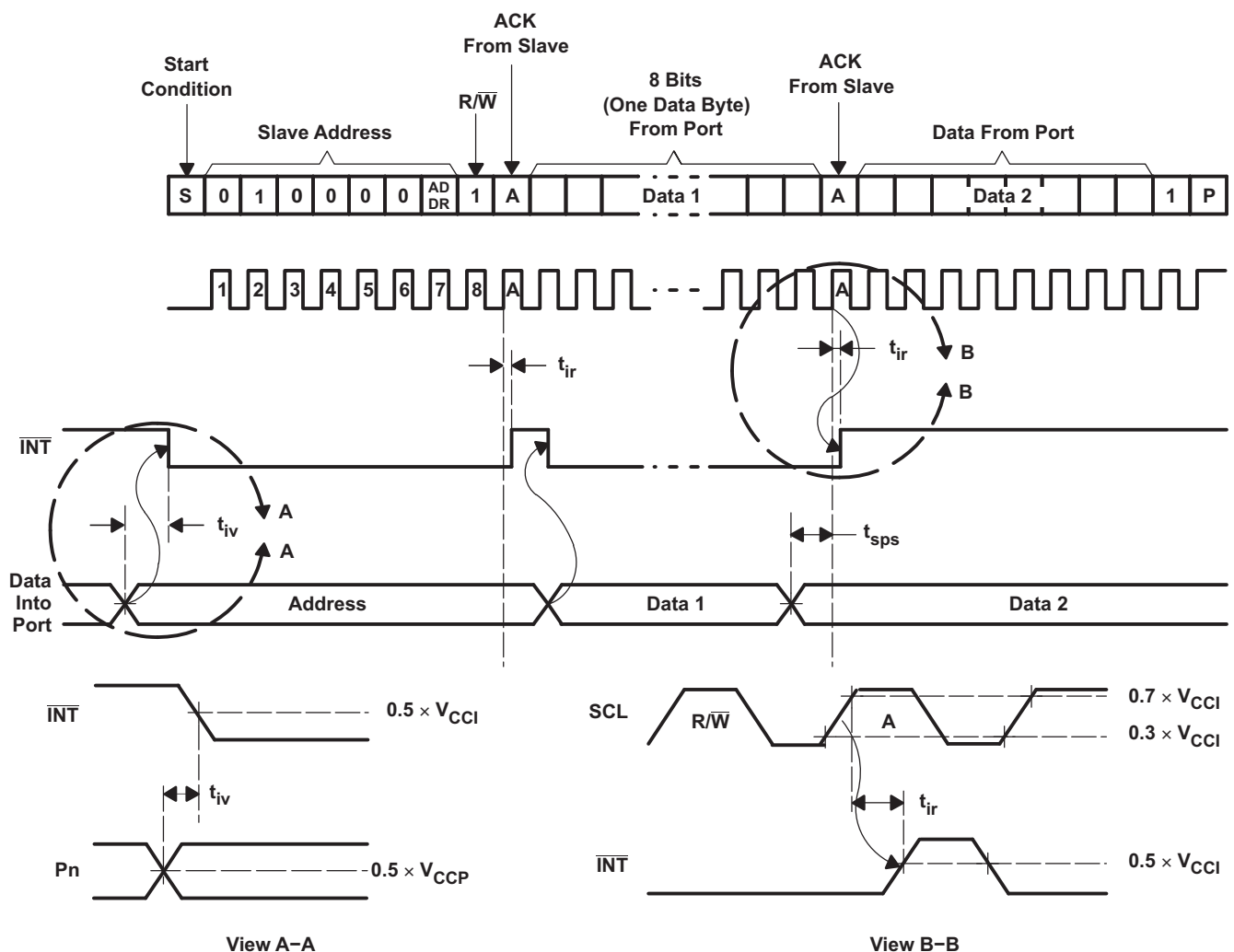

- A.  $C_L$  includes probe and jig capacitance.
- B. All inputs are supplied by generators having the following characteristics:  $PRR \leq 10$  MHz,  $Z_O = 50 \Omega$ ,  $t_r/t_f \leq 30$  ns.
- C. All parameters and waveforms are not applicable to all devices.

Figure 15. Interrupt Load Circuit And Voltage Waveforms

Parameter Measurement Information (continued)

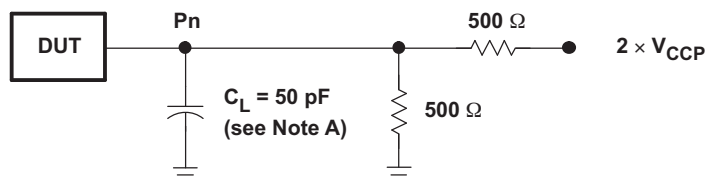

P-PORT LOAD CONFIGURATION

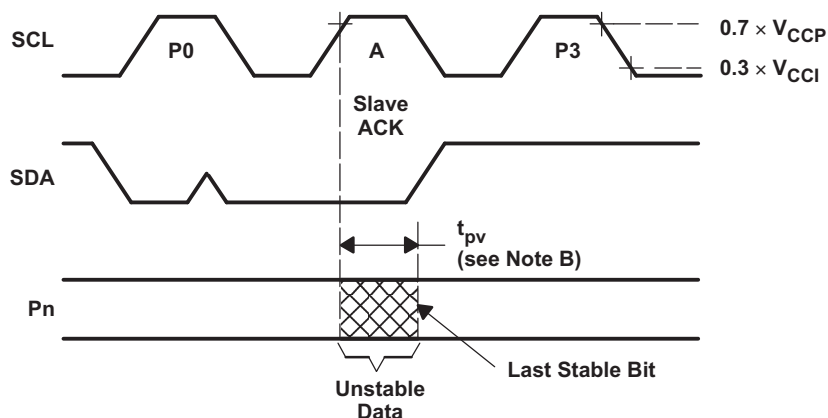

WRITE MODE ( $R/\bar{W} = 0$ )

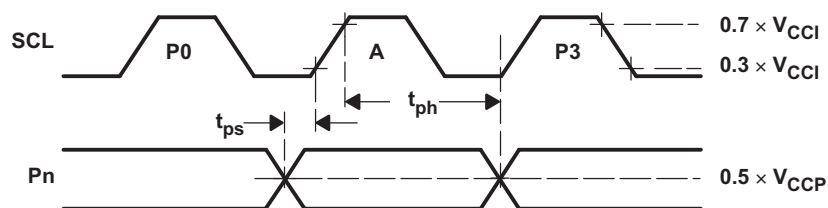

READ MODE ( $R/\bar{W} = 1$ )

- A.  $C_L$  includes probe and jig capacitance.
- B.  $t_{pv}$  is measured from  $0.7 \times V_{CC}$  on SCL to 50% I/O ( $P_n$ ) output.
- C. All inputs are supplied by generators having the following characteristics:  $PRR \leq 10$  MHz,  $Z_0 = 50 \Omega$ ,  $t_r/t_f \leq 30$  ns.
- D. The outputs are measured one at a time, with one transition per measurement.
- E. All parameters and waveforms are not applicable to all devices.

Figure 16. P-Port Load Circuit And Timing Waveforms

Parameter Measurement Information (continued)

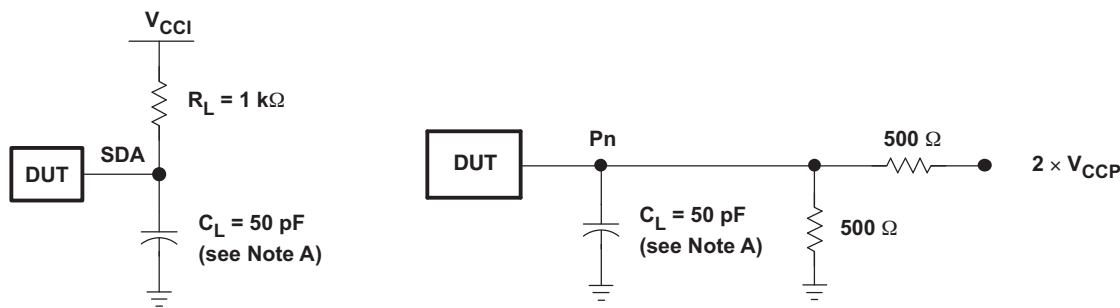

SDA LOAD CONFIGURATION

P-PORT LOAD CONFIGURATION

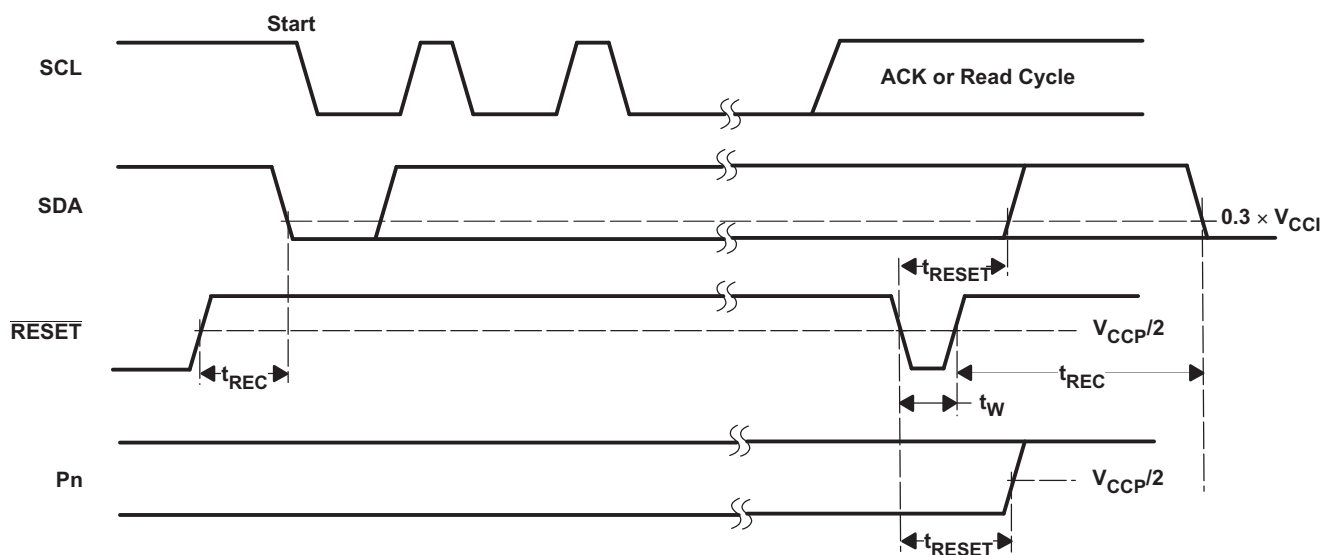

- A.  $C_L$  includes probe and jig capacitance.
- B. All inputs are supplied by generators having the following characteristics:  $PRR \leq 10$  MHz,  $Z_O = 50 \Omega$ ,  $t_r/t_f \leq 30$  ns.
- C. The outputs are measured one at a time, with one transition per measurement.
- D. I/Os are configured as inputs.
- E. All parameters and waveforms are not applicable to all devices.

Figure 17. Reset Load Circuits And Voltage Waveforms

## 8 Detailed Description

### 8.1 Functional Block Diagram

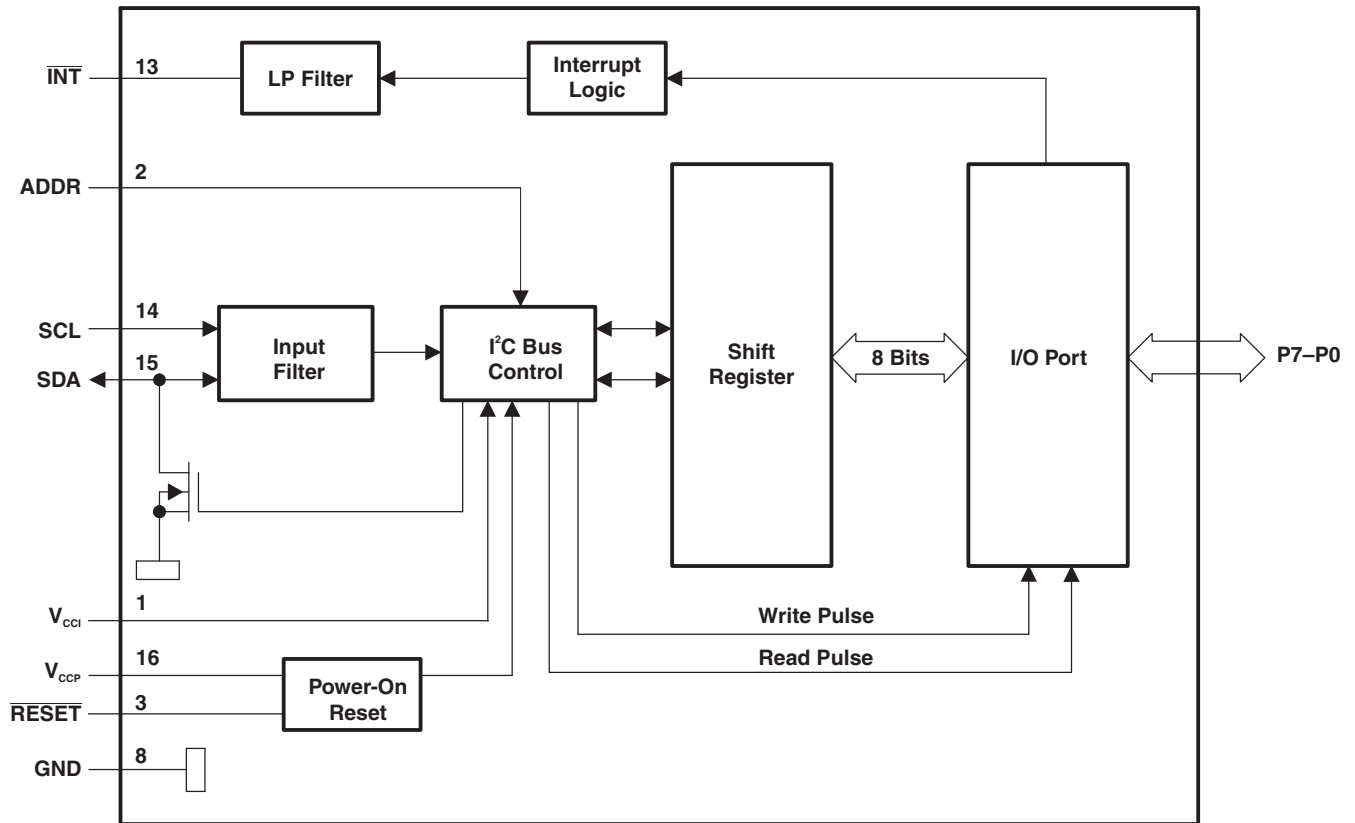

- A. All pin numbers shown are for the PW package.
- B. All I/Os are set to inputs at reset.

Figure 18. Logic Diagram (Positive Logic)

Functional Block Diagram (continued)

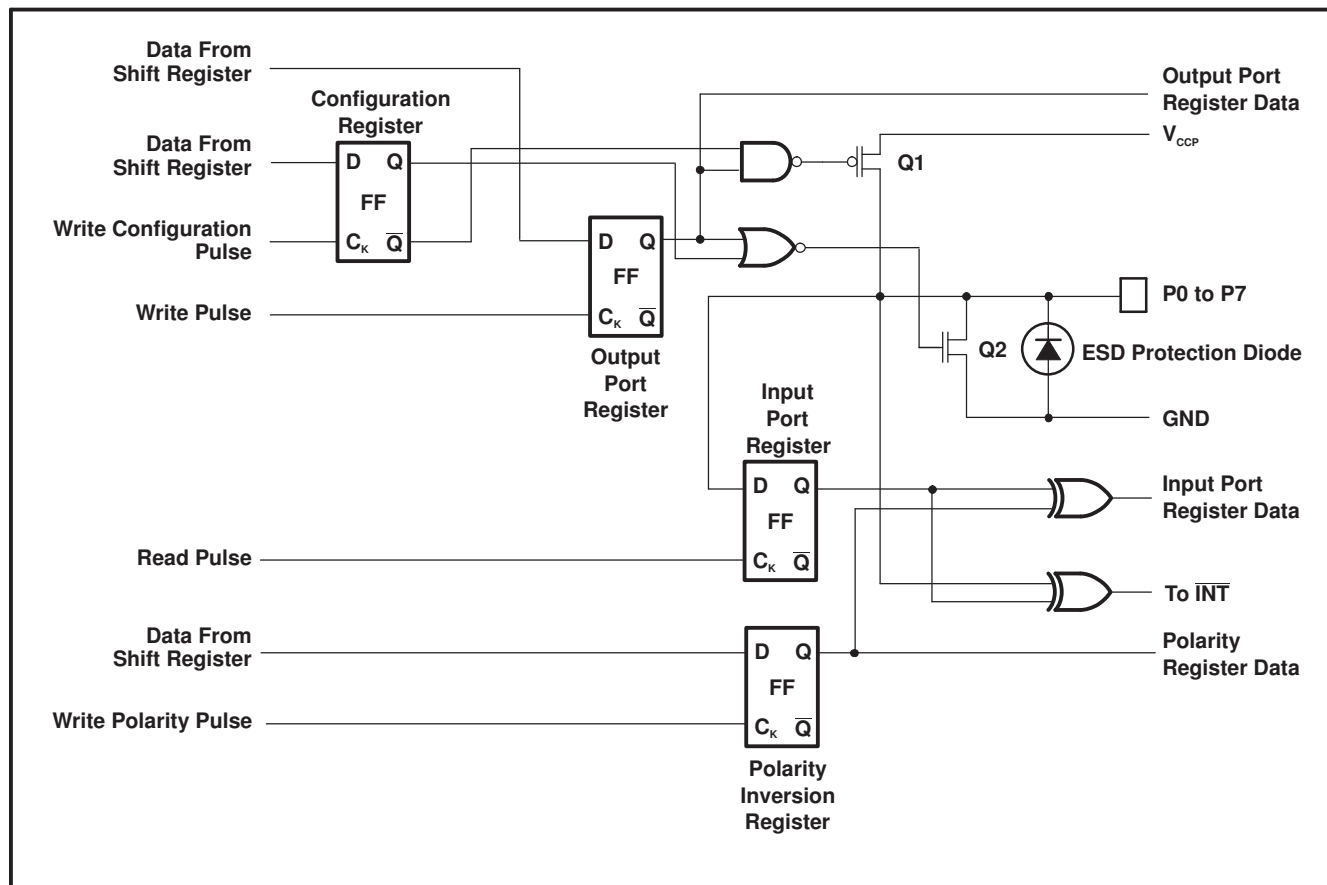

A. On power up or reset, all registers return to default values.

Figure 19. Simplified Schematic Of P0 To P7



## 8.2 Device Functional Modes

### 8.2.1 Voltage Translation

Table 1 shows how to set up  $V_{CC}$  levels for the necessary voltage translation between the I<sup>2</sup>C bus and the TCA6408.

**Table 1. Voltage Translation**

$V_{CCI}$ (SCL AND SDA OF I <sup>2</sup> C MASTER) (V)	$V_{CCP}$ (P PORT) (V)
1.8	1.8
1.8	2.5
1.8	3.3
1.8	5
2.5	1.8
2.5	2.5
2.5	3.3
2.5	5
3.3	1.8
3.3	2.5
3.3	3.3
3.3	5
5	1.8
5	2.5
5	3.3
5	5

### 8.2.2 Reset ( $\overline{\text{RESET}}$ ) Input

The  $\overline{\text{RESET}}$  input can be asserted to initialize the system while keeping  $V_{CCP}$  at its operating level. A reset can be accomplished by holding the  $\overline{\text{RESET}}$  pin low for a minimum of  $t_W$ . The TCA6408 registers and I<sup>2</sup>C/SMBus state machine are changed to their default state once  $\overline{\text{RESET}}$  is low (0). When  $\overline{\text{RESET}}$  is high (1), the I/O levels at the P port can be changed externally or through the master. This input requires a pullup resistor to  $V_{CCP}$ , if no active connection is used.

#### 8.2.2.1 $\overline{\text{RESET}}$ Errata

If  $\overline{\text{RESET}}$  voltage set higher than VCC, current will flow from  $\overline{\text{RESET}}$  pin to VCC pin.

#### System Impact

VCC will be pulled above its regular voltage level

#### System Workaround

Design such that  $\overline{\text{RESET}}$  voltage is same or lower than VCC

### 8.2.3 Power-On Reset

When power (from 0 V) is applied to  $V_{CCP}$ , an internal power-on reset holds the TCA6408 in a reset condition until  $V_{CCP}$  has reached  $V_{POR}$ . At that time, the reset condition is released, and the TCA6408 registers and I<sup>2</sup>C/SMBus state machine initialize to their default states. After that,  $V_{CCP}$  must be lowered to below 0.2 V and back up to the operating voltage for a power-reset cycle.

**TCA6408**

SCPS151D – FEBRUARY 2007 – REVISED JUNE 2014

www.ti.com

**8.2.4 I/O Port**

When an I/O is configured as an input, FETs Q1 and Q2 (in Figure 19) are off, which creates a high-impedance input. The input voltage may be raised above  $V_{CC}$  to a maximum of 5.5 V.

If the I/O is configured as an output, Q1 or Q2 is enabled depending on the state of the Output Port Register. In this case, there are low impedance paths between the I/O pin and either  $V_{CC}$  or GND. The external voltage applied to this I/O pin should not exceed the recommended levels for proper operation.

**8.2.5 Interrupt ( $\overline{\text{INT}}$ ) Output**

An interrupt is generated by any rising or falling edge of the port inputs in the input mode. After time  $t_{iv}$ , the signal  $\overline{\text{INT}}$  is valid. Resetting the interrupt circuit is achieved when data on the port is changed to the original setting, data is read from the port that generated the interrupt or in a stop event. Resetting occurs in the read mode at the acknowledge (ACK) or not acknowledge (NACK) bit after the rising edge of the SCL signal. Interrupts that occur during the ACK or NACK clock pulse can be lost (or be very short) due to the resetting of the interrupt during this pulse. Each change of the I/Os after resetting is detected and is transmitted as  $\overline{\text{INT}}$ .

Reading from or writing to another device does not affect the interrupt circuit, and a pin configured as an output cannot cause an interrupt. Changing an I/O from an output to an input may cause a false interrupt to occur, if the state of the pin does not match the contents of the Input Port register.

In the TCA6408, an interrupt is not immediately generated by any rising or falling edge of port inputs in input mode after issuing any I<sup>2</sup>C commands (read or write). In order to capture the  $\overline{\text{INT}}$  in the TCA6408, the user needs to add one more SCL clock pulse after a Stop signal.

The  $\overline{\text{INT}}$  output has an open-drain structure and requires a pullup resistor to  $V_{CCP}$  or  $V_{CCI}$  depending on the application. If the  $\overline{\text{INT}}$  signal is connected back to the processor that provides the SCL signal to the TCA6408, then the  $\overline{\text{INT}}$  pin has to be connected to  $V_{CCI}$ . If not, the INT pin can be connected to  $V_{CCP}$ .

**8.2.5.1 Interrupt Errata**

The INT will be improperly de-asserted if the following two conditions occur:

1. The last I<sup>2</sup>C command byte (register pointer) written to the device was 00h.

**NOTE**

This generally means the last operation with the device was a Read of the input register. However, the command byte may have been written with 00h without ever going on to read the input register. After reading from the device, if no other command byte written, it will remain 00h.

2. Any other slave device on the I<sup>2</sup>C bus acknowledges an address byte with the R/W bit set high

**System Impact**

Can cause improper interrupt handling as the Master will see the interrupt as being cleared.

**System Workaround**

Minor software change: User must change command byte to something besides 00h after a Read operation to the TCA6408 device or before reading from another slave device.

**NOTE**

Software change will be compatible with other versions (competition and TI redesigns) of this device.

## 8.3 Programming

### 8.3.1 I<sup>2</sup>C Interface

The bidirectional I<sup>2</sup>C bus consists of the serial clock (SCL) and serial data (SDA) lines. Both lines must be connected to a positive supply through a pullup resistor when connected to the output stages of a device. Data transfer may be initiated only when the bus is not busy.

I<sup>2</sup>C communication with this device is initiated by a master sending a Start condition, a high-to-low transition on the SDA input/output, while the SCL input is high (see Figure 20). After the Start condition, the device address byte is sent, most significant bit (MSB) first, including the data direction bit (R/W).

After receiving the valid address byte, this device responds with an acknowledge (ACK), a low on the SDA input/output during the high of the ACK-related clock pulse. The address (ADDR) input of the slave device must not be changed between the Start and the Stop conditions.

On the I<sup>2</sup>C bus, only one data bit is transferred during each clock pulse. The data on the SDA line must remain stable during the high pulse of the clock period, as changes in the data line at this time are interpreted as control commands (Start or Stop) (see Figure 21).

A Stop condition, a low-to-high transition on the SDA input/output while the SCL input is high, is sent by the master (see Figure 20).

Any number of data bytes can be transferred from the transmitter to receiver between the Start and the Stop conditions. Each byte of eight bits is followed by one ACK bit. The transmitter must release the SDA line before the receiver can send an ACK bit. The device that acknowledges must pull down the SDA line during the ACK clock pulse, so that the SDA line is stable low during the high pulse of the ACK-related clock period (see Figure 22). When a slave receiver is addressed, it must generate an ACK after each byte is received. Similarly, the master must generate an ACK after each byte that it receives from the slave transmitter. Setup and hold times must be met to ensure proper operation.

A master receiver signals an end of data to the slave transmitter by not generating an acknowledge (NACK) after the last byte has been clocked out of the slave. This is done by the master receiver by holding the SDA line high. In this event, the transmitter must release the data line to enable the master to generate a Stop condition.

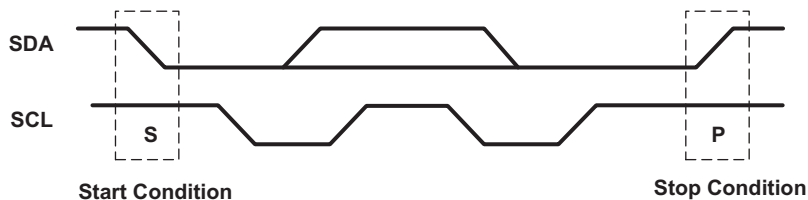

**Figure 20. Definition Of Start And Stop Conditions**

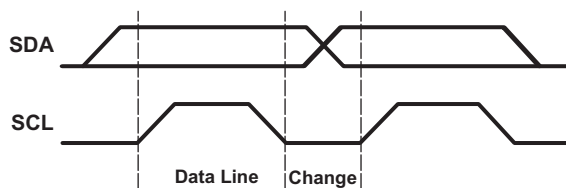

**Figure 21. Bit Transfer**

Programming (continued)

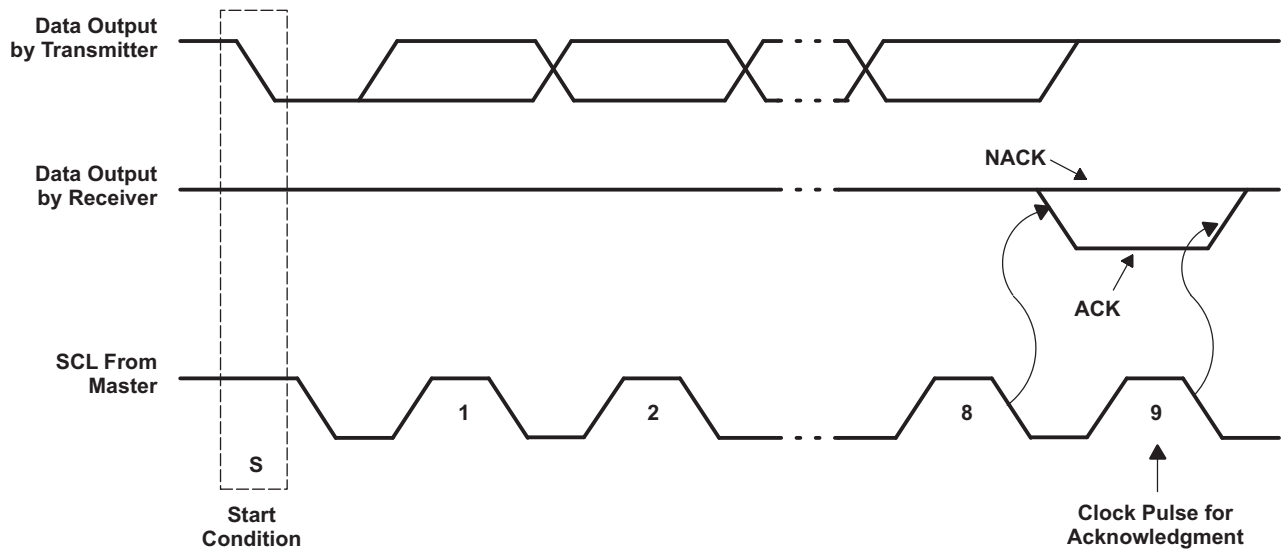

Figure 22. Acknowledgment On I<sup>2</sup>C Bus

8.3.2 Register Map

Table 2. Interface Definition

BYTE	BIT							
	7 (MSB)	6	5	4	3	2	1	0 (LSB)
I <sup>2</sup> C slave address	L	H	L	L	L	L	ADDR	R/ $\overline{W}$
I/O data bus	P7	P6	P5	P4	P3	P2	P1	P0

8.3.2.1 Device Address

The address of the TCA6408 is shown in Figure 23.

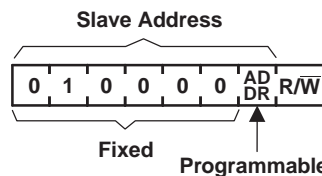

Figure 23. Tca6408 Address

Table 3. Address Reference

ADDR	I <sup>2</sup> C BUS SLAVE ADDRESS
L	32 (decimal), 20 (hexadecimal)
H	33 (decimal), 21 (hexadecimal)

The last bit of the slave address defines the operation (read or write) to be performed. A high (1) selects a read operation, while a low (0) selects a write operation.

### 8.3.2.2 Control Register And Command Byte

Following the successful acknowledgement of the address byte, the bus master sends a command byte, which is stored in the Control Register in the TCA6408. Two bits of this data byte state the operation (read or write) and the internal registers (Input, Output, Polarity Inversion, or Configuration) that will be affected. This register can be written or read through the I<sup>2</sup>C bus. The command byte is sent only during a write transmission.

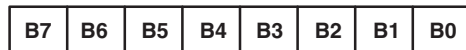

**Figure 24. Control Register Bits**

**Table 4. Command Byte**

CONTROL REGISTER BITS								COMMAND BYTE (HEX)	REGISTER	PROTOCOL	POWER-UP DEFAULT
B7	B6	B5	B4	B3	B2	B1	B0				
0	0	0	0	0	0	0	0	00	Input Port	Read byte	xxxx xxxx <sup>(1)</sup>
0	0	0	0	0	0	0	1	01	Output Port	Read/write byte	1111 1111
0	0	0	0	0	0	1	0	02	Polarity Inversion	Read/write byte	0000 0000
0	0	0	0	0	0	1	1	03	Configuration	Read/write byte	1111 1111

(1) Undefined

### 8.3.2.3 Register Descriptions

The Input Port Register (register 0) reflects the incoming logic levels of the pins, regardless of whether the pin is defined as an input or an output by the Configuration Register. Writes to this register have no effect. The default value (X) is determined by the externally applied logic level. Before a read operation, a write transmission is sent with the command byte to indicate to the I<sup>2</sup>C device that the Input Port Register will be accessed next.

**Table 5. Register 0 (Input Port Register)**

BIT	I-7	I-6	I-5	I-4	I-3	I-2	I-1	I-0
DEFAULT	X	X	X	X	X	X	X	X

The Output Port Register (register 1) shows the outgoing logic levels of the pins defined as outputs by the Configuration Register. Bit values in this register have no effect on pins defined as inputs. In turn, reads from this register reflect the value that is in the flip-flop controlling the output selection, not the actual pin value.

**Table 6. Register 1 (Output Port Register)**

BIT	O-7	O-6	O-5	O-4	O-3	O-2	O-1	O-0
DEFAULT	1	1	1	1	1	1	1	1

The Polarity Inversion Register (register 2) allows polarity inversion of pins defined as inputs by the Configuration Register. If a bit in this register is set (written with 1), the corresponding port pin's polarity is inverted. If a bit in this register is cleared (written with a 0), the corresponding port pin's original polarity is retained.

**Table 7. Register 2 (Polarity Inversion Register)**

BIT	N-7	N-6	N-5	N-4	N-3	N-2	N-1	N-0
DEFAULT	0	0	0	0	0	0	0	0

The Configuration Register (register 3) configures the direction of the I/O pins. If a bit in this register is set to 1, the corresponding port pin is enabled as an input with a high-impedance output driver. If a bit in this register is cleared to 0, the corresponding port pin is enabled as an output.

**Table 8. Register 3 (Configuration Register)**

BIT	C-7	C-6	C-5	C-4	C-3	C-2	C-1	C-0
DEFAULT	1	1	1	1	1	1	1	1

**8.3.2.4 Bus Transactions**

Data is exchanged between the master and TCA6408 through write and read commands.

**8.3.2.4.1 Writes**

Data is transmitted to the TCA6408 by sending the device address and setting the least significant bit (LSB) to a logic 0 (see Figure 23 for device address). The command byte is sent after the address and determines which register receives the data that follows the command byte. There is no limitation on the number of data bytes sent in one write transmission.

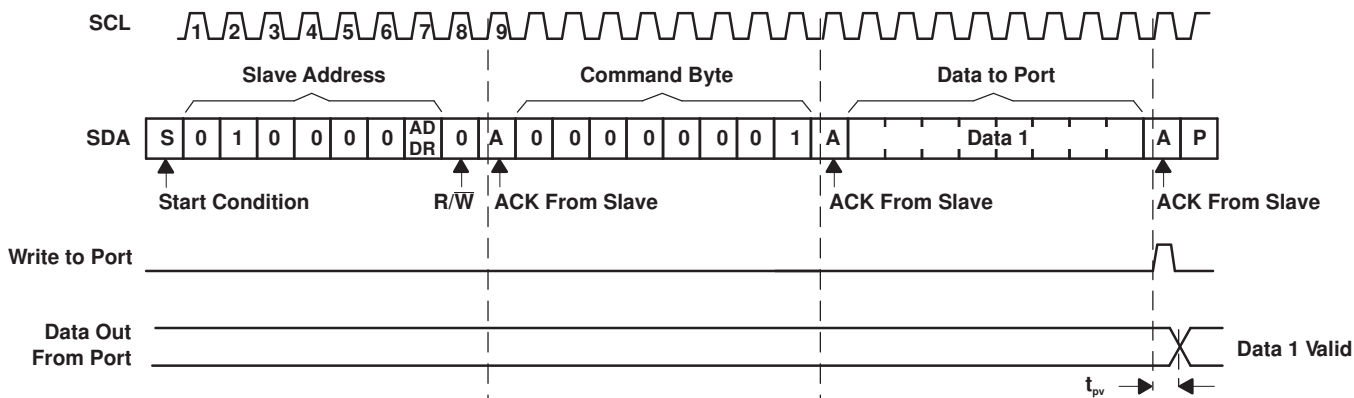

**Figure 25. Write To Output Port Register**

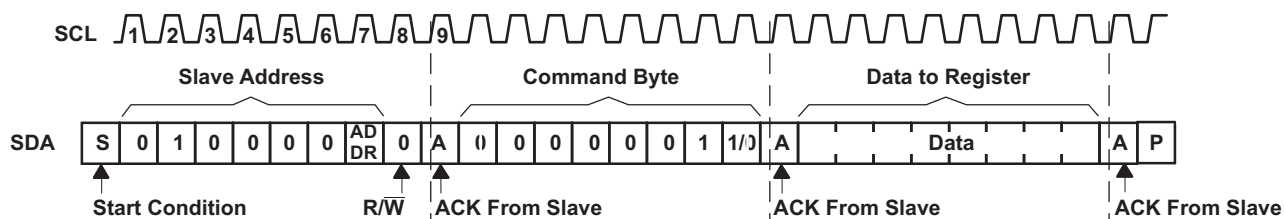

**Figure 26. Write To Configuration Or Polarity Inversion Registers**

**TCA6408**

SCPS151D – FEBRUARY 2007 – REVISED JUNE 2014

www.ti.com

**8.3.2.4.2 Reads**

The bus master first must send the TCA6408 address with the LSB set to a logic 0 (see Figure 23 for device address). The command byte is sent after the address and determines which register is accessed.

After a restart, the device address is sent again but, this time, the LSB is set to a logic 1. Data from the register defined by the command byte then is sent by the TCA6408 (see Figure 27 and Figure 28).

Data is clocked into the register on the rising edge of the ACK clock pulse.

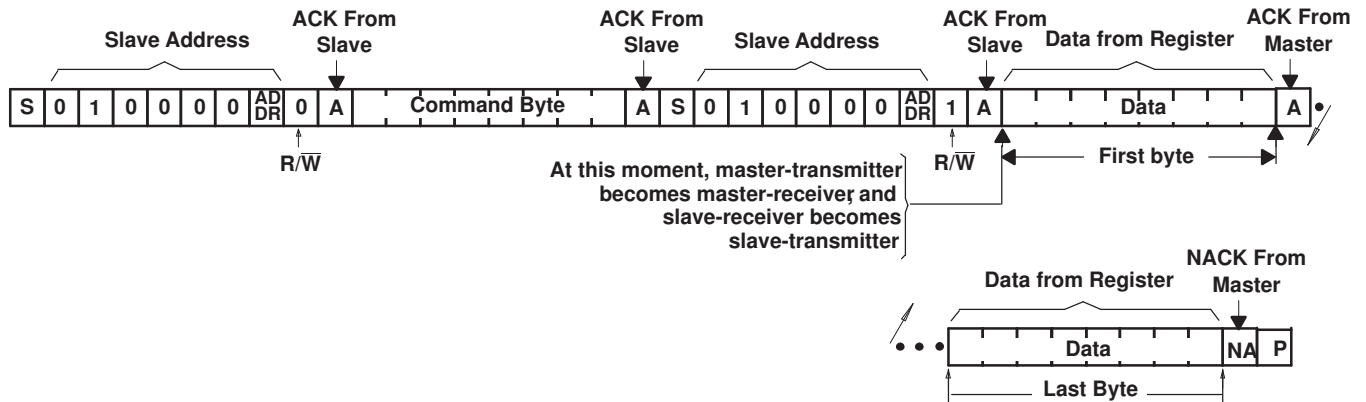

**Figure 27. Read From Register**

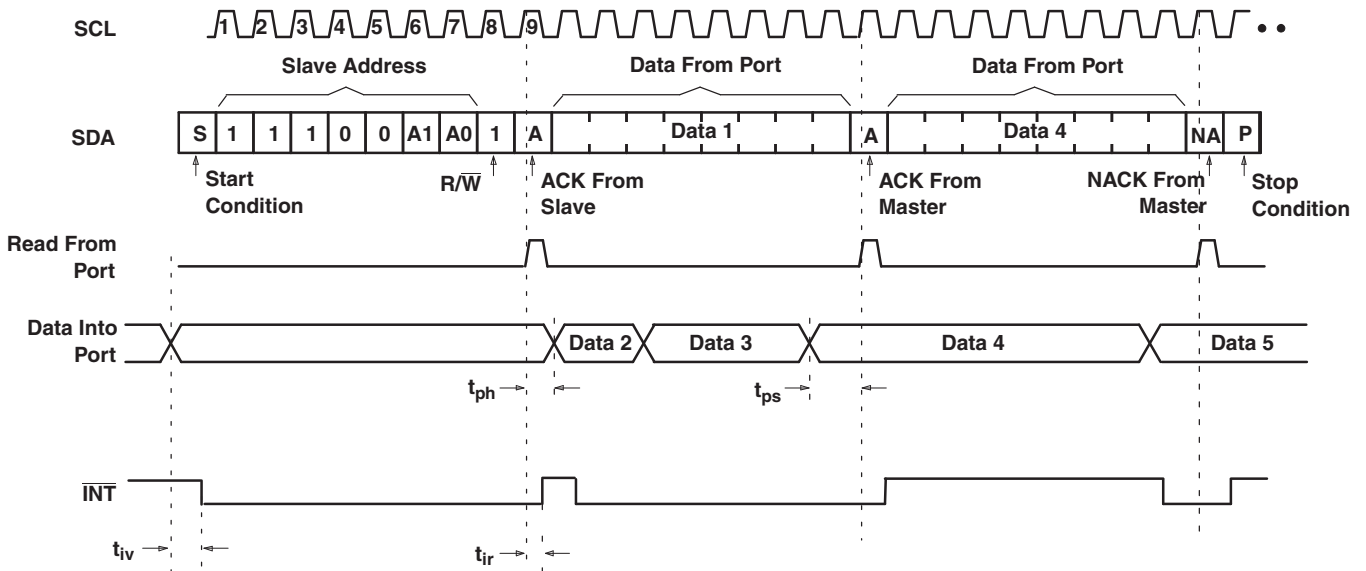

- A. Transfer of data can be stopped at any time by a Stop condition. When this occurs, data present at the latest acknowledge phase is valid (output mode). It is assumed that the command byte previously has been set to 00 (read Input Port Register).
- B. This figure eliminates the command byte transfer, a restart, and slave address call between the initial slave address call and actual data transfer from P port (see Figure 27).

**Figure 28. Read From Input Port Register**



## 9 Application And Implementation

### 9.1 Typical Application

Figure 29 shows an application in which the TCA6408 can be used.

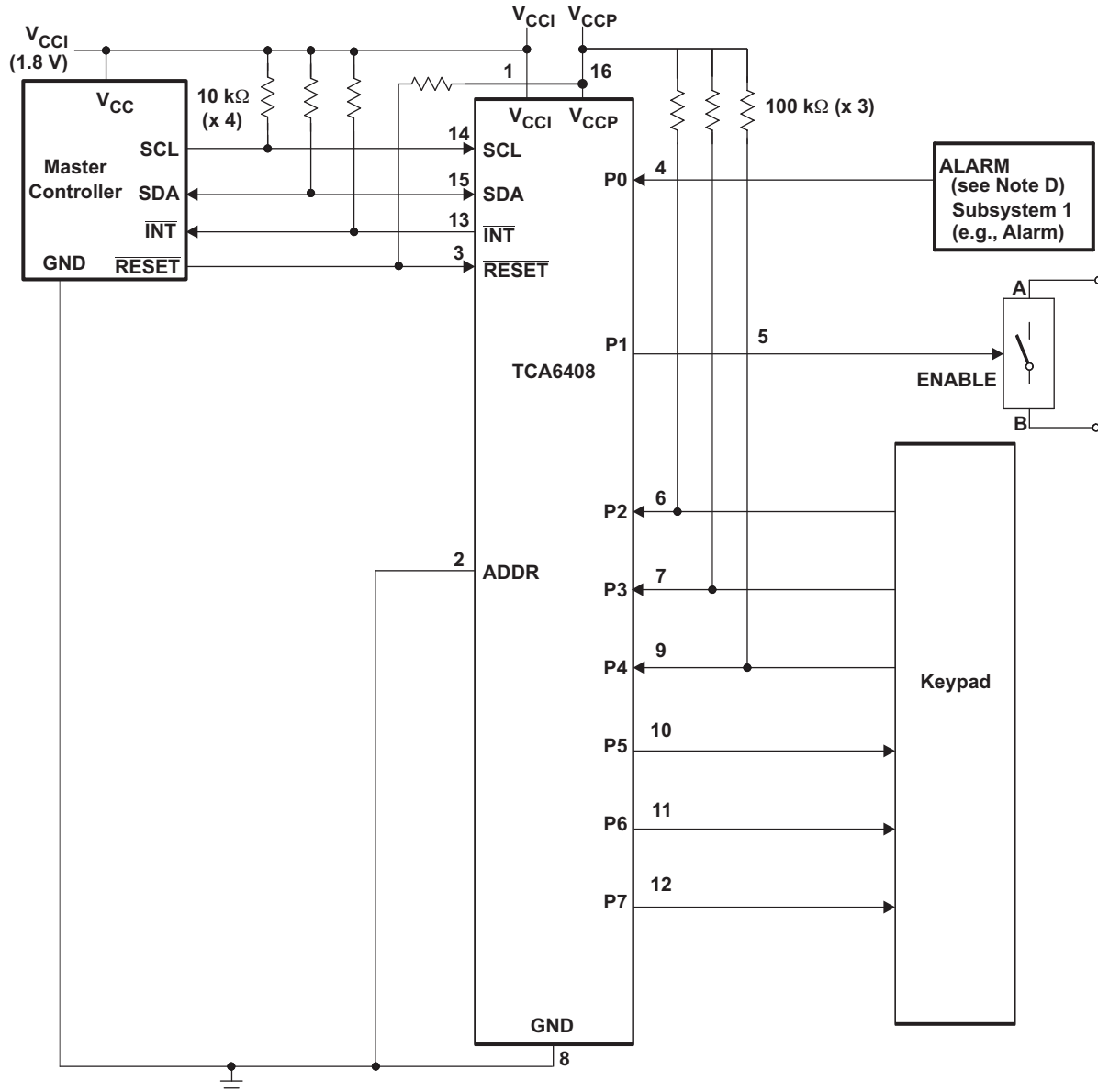

- A. Device address configured as 0100000 for this example.
- B. P0 and P2–P4 are configured as inputs.
- C. P1 and P5–P7 are configured as outputs.
- D. Resistors are required for inputs (on P port) that may float. If a driver to an input will never let the input float, a resistor is not needed. Outputs (in the P port) do not need pullup resistors.

Figure 29. Typical Application

## Typical Application (continued)

### 9.1.1 Design Requirements

#### 9.1.1.1 Minimizing $I_{CC}$ When I/O Is Used To Control Leds

When the I/Os are used to control LEDs, normally they are connected to  $V_{CC}$  through a resistor as shown in Figure 29. The LED acts as a diode so when the LED is off, the I/O  $V_{IN}$  is about 1.2 V less than  $V_{CC}$ . The  $\Delta I_{CC}$  parameter in Electrical Characteristics shows how  $I_{CC}$  increases as  $V_{IN}$  becomes lower than  $V_{CC}$ . Designs that must minimize current consumption, such as battery power applications, should consider maintaining the I/O pins greater than or equal to  $V_{CC}$  when the LED is off.

Figure 30 shows a high-value resistor in parallel with the LED. Figure 31 shows  $V_{CC}$  less than the LED supply voltage by at least 1.2 V. Both of these methods maintain the I/O  $V_{IN}$  at or above  $V_{CC}$  and prevent additional supply current consumption when the LED is off.

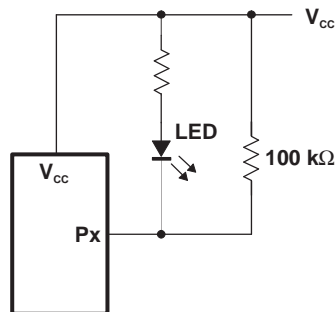

Figure 30. High-Value Resistor In Parallel With Led

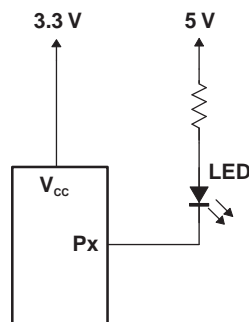

Figure 31. Device Supplied By A Low Voltage

## 10 Device and Documentation Support

### 10.1 Trademarks

All trademarks are the property of their respective owners.

### 10.2 Electrostatic Discharge Caution



These devices have limited built-in ESD protection. The leads should be shorted together or the device placed in conductive foam during storage or handling to prevent electrostatic damage to the MOS gates.

### 10.3 Glossary

[SLYZ022](#) — *TI Glossary*.

This glossary lists and explains terms, acronyms, and definitions.

## 11 Mechanical, Packaging, and Orderable Information

The following pages include mechanical, packaging, and orderable information. This information is the most current data available for the designated devices. This data is subject to change without notice and revision of this document. For browser-based versions of this data sheet, refer to the left-hand navigation.

**PACKAGING INFORMATION**

Orderable Device	Status (1)	Package Type	Package Drawing	Pins	Package Qty	Eco Plan (2)	Lead/Ball Finish (6)	MSL Peak Temp (3)	Op Temp (°C)	Device Marking (4/5)	Samples
TCA6408PW	OBSOLETE	TSSOP	PW	16		TBD	Call TI	Call TI	-40 to 85	PH408	
TCA6408PWG4	OBSOLETE	TSSOP	PW	16		TBD	Call TI	Call TI	-40 to 85	PH408	
TCA6408PWR	OBSOLETE	TSSOP	PW	16		TBD	Call TI	Call TI	-40 to 85	PH408	
TCA6408PWRG4	OBSOLETE	TSSOP	PW	16		TBD	Call TI	Call TI	-40 to 85	PH408	
TCA6408RGTR	OBSOLETE	QFN	RGT	16		TBD	Call TI	Call TI	-40 to 85	ZWP	
TCA6408ZXYP	OBSOLETE	BGA MICROSTAR JUNIOR	ZXY	20		TBD	Call TI	Call TI	-40 to 85	PH408	

(1) The marketing status values are defined as follows:

**ACTIVE:** Product device recommended for new designs.

**LIFEBUY:** TI has announced that the device will be discontinued, and a lifetime-buy period is in effect.

**NRND:** Not recommended for new designs. Device is in production to support existing customers, but TI does not recommend using this part in a new design.

**PREVIEW:** Device has been announced but is not in production. Samples may or may not be available.

**OBSOLETE:** TI has discontinued the production of the device.

(2) Eco Plan - The planned eco-friendly classification: Pb-Free (RoHS), Pb-Free (RoHS Exempt), or Green (RoHS & no Sb/Br) - please check <http://www.ti.com/productcontent> for the latest availability information and additional product content details.

**TBD:** The Pb-Free/Green conversion plan has not been defined.

**Pb-Free (RoHS):** TI's terms "Lead-Free" or "Pb-Free" mean semiconductor products that are compatible with the current RoHS requirements for all 6 substances, including the requirement that lead not exceed 0.1% by weight in homogeneous materials. Where designed to be soldered at high temperatures, TI Pb-Free products are suitable for use in specified lead-free processes.

**Pb-Free (RoHS Exempt):** This component has a RoHS exemption for either 1) lead-based flip-chip solder bumps used between the die and package, or 2) lead-based die adhesive used between the die and leadframe. The component is otherwise considered Pb-Free (RoHS compatible) as defined above.

**Green (RoHS & no Sb/Br):** TI defines "Green" to mean Pb-Free (RoHS compatible), and free of Bromine (Br) and Antimony (Sb) based flame retardants (Br or Sb do not exceed 0.1% by weight in homogeneous material)

(3) MSL, Peak Temp. - The Moisture Sensitivity Level rating according to the JEDEC industry standard classifications, and peak solder temperature.

(4) There may be additional marking, which relates to the logo, the lot trace code information, or the environmental category on the device.

(5) Multiple Device Markings will be inside parentheses. Only one Device Marking contained in parentheses and separated by a "-" will appear on a device. If a line is indented then it is a continuation of the previous line and the two combined represent the entire Device Marking for that device.

(6) Lead/Ball Finish - Orderable Devices may have multiple material finish options. Finish options are separated by a vertical ruled line. Lead/Ball Finish values may wrap to two lines if the finish value exceeds the maximum column width.

**Important Information and Disclaimer:** The information provided on this page represents TI's knowledge and belief as of the date that it is provided. TI bases its knowledge and belief on information provided by third parties, and makes no representation or warranty as to the accuracy of such information. Efforts are underway to better integrate information from third parties. TI has taken and continues to take reasonable steps to provide representative and accurate information but may not have conducted destructive testing or chemical analysis on incoming materials and chemicals. TI and TI suppliers consider certain information to be proprietary, and thus CAS numbers and other limited information may not be available for release.

In no event shall TI's liability arising out of such information exceed the total purchase price of the TI part(s) at issue in this document sold by TI to Customer on an annual basis.

PW (R-PDSO-G16)

PLASTIC SMALL OUTLINE



4040064-4/G 02/11

- NOTES:
- A. All linear dimensions are in millimeters. Dimensioning and tolerancing per ASME Y14.5M-1994.
  - B. This drawing is subject to change without notice.
  - C. Body length does not include mold flash, protrusions, or gate burrs. Mold flash, protrusions, or gate burrs shall not exceed 0,15 each side.
  - D. Body width does not include interlead flash. Interlead flash shall not exceed 0,25 each side.
  - E. Falls within JEDEC MO-153

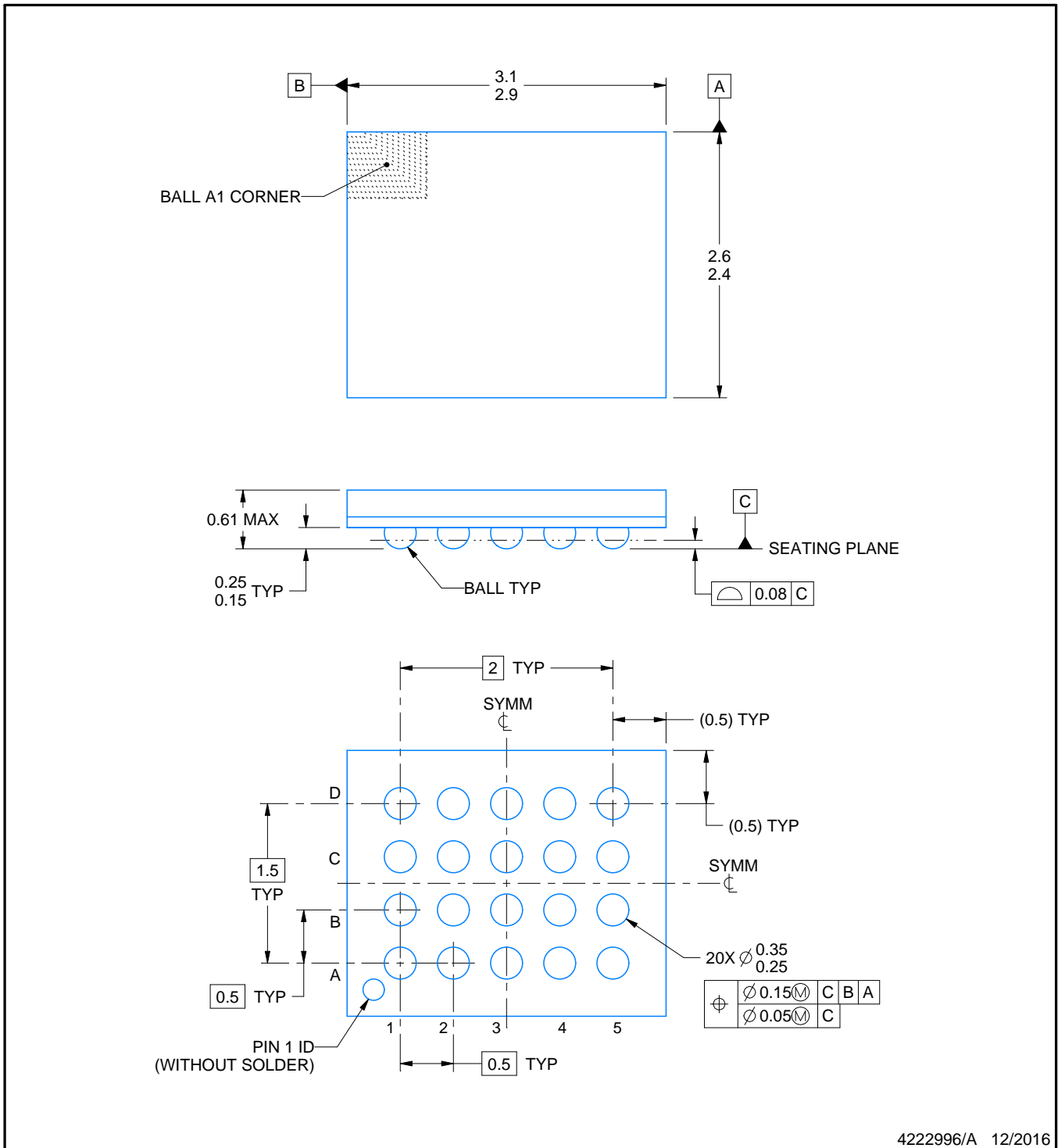
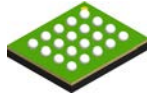

4222996/A 12/2016

NOTES:

1. All linear dimensions are in millimeters. Any dimensions in parenthesis are for reference only. Dimensioning and tolerancing per ASME Y14.5M.
2. This drawing is subject to change without notice.

# EXAMPLE BOARD LAYOUT

ZXY0020A

VFBGA - 0.61 mm max height

PLASTIC BALL GRID ARRAY

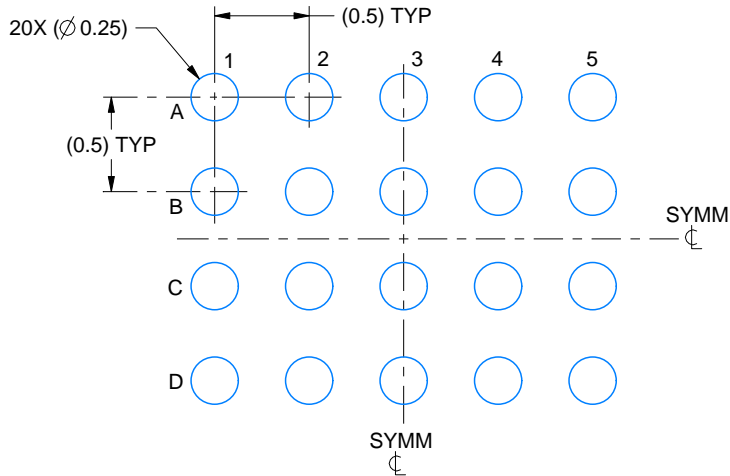

LAND PATTERN EXAMPLE  
EXPOSED METAL SHOWN  
SCALE:25X

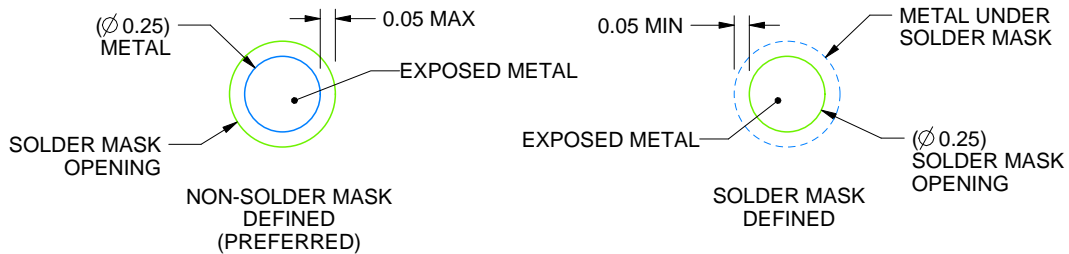

SOLDER MASK DETAILS  
NOT TO SCALE

4222996/A 12/2016

NOTES: (continued)

- Final dimensions may vary due to manufacturing tolerance considerations and also routing constraints. For information, see Texas Instruments literature number SPRAA99 ([www.ti.com/lit/spraa99](http://www.ti.com/lit/spraa99)).



# EXAMPLE STENCIL DESIGN

ZXY0020A

VFBGA - 0.61 mm max height

PLASTIC BALL GRID ARRAY

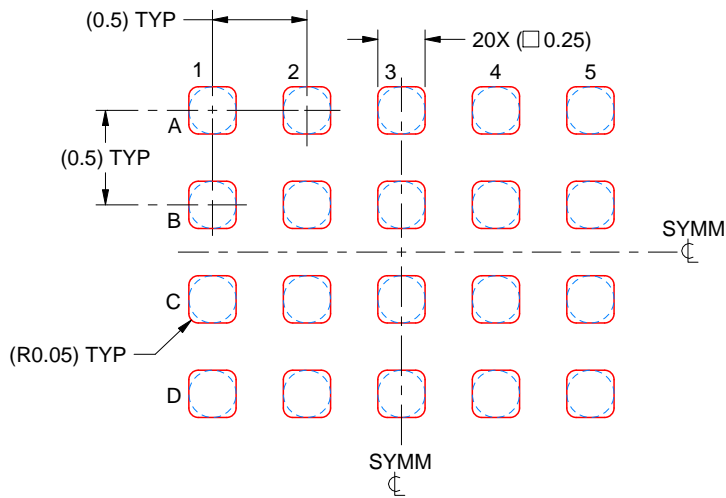

SOLDER PASTE EXAMPLE  
BASED ON 0.1 mm THICK STENCIL  
SCALE: 25X

4222996/A 12/2016

NOTES: (continued)

4. Laser cutting apertures with trapezoidal walls and rounded corners may offer better paste release.

**RGT 16**

**GENERIC PACKAGE VIEW**

**VQFN - 1 mm max height**

PLASTIC QUAD FLATPACK - NO LEAD



Images above are just a representation of the package family, actual package may vary.  
Refer to the product data sheet for package details.

4203495/1

## IMPORTANT NOTICE FOR TI DESIGN INFORMATION AND RESOURCES

Texas Instruments Incorporated ("TI") technical, application or other design advice, services or information, including, but not limited to, reference designs and materials relating to evaluation modules, (collectively, "TI Resources") are intended to assist designers who are developing applications that incorporate TI products; by downloading, accessing or using any particular TI Resource in any way, you (individually or, if you are acting on behalf of a company, your company) agree to use it solely for this purpose and subject to the terms of this Notice.

TI's provision of TI Resources does not expand or otherwise alter TI's applicable published warranties or warranty disclaimers for TI products, and no additional obligations or liabilities arise from TI providing such TI Resources. TI reserves the right to make corrections, enhancements, improvements and other changes to its TI Resources.

You understand and agree that you remain responsible for using your independent analysis, evaluation and judgment in designing your applications and that you have full and exclusive responsibility to assure the safety of your applications and compliance of your applications (and of all TI products used in or for your applications) with all applicable regulations, laws and other applicable requirements. You represent that, with respect to your applications, you have all the necessary expertise to create and implement safeguards that (1) anticipate dangerous consequences of failures, (2) monitor failures and their consequences, and (3) lessen the likelihood of failures that might cause harm and take appropriate actions. You agree that prior to using or distributing any applications that include TI products, you will thoroughly test such applications and the functionality of such TI products as used in such applications. TI has not conducted any testing other than that specifically described in the published documentation for a particular TI Resource.

You are authorized to use, copy and modify any individual TI Resource only in connection with the development of applications that include the TI product(s) identified in such TI Resource. NO OTHER LICENSE, EXPRESS OR IMPLIED, BY ESTOPPEL OR OTHERWISE TO ANY OTHER TI INTELLECTUAL PROPERTY RIGHT, AND NO LICENSE TO ANY TECHNOLOGY OR INTELLECTUAL PROPERTY RIGHT OF TI OR ANY THIRD PARTY IS GRANTED HEREIN, including but not limited to any patent right, copyright, mask work right, or other intellectual property right relating to any combination, machine, or process in which TI products or services are used. Information regarding or referencing third-party products or services does not constitute a license to use such products or services, or a warranty or endorsement thereof. Use of TI Resources may require a license from a third party under the patents or other intellectual property of the third party, or a license from TI under the patents or other intellectual property of TI.

TI RESOURCES ARE PROVIDED "AS IS" AND WITH ALL FAULTS. TI DISCLAIMS ALL OTHER WARRANTIES OR REPRESENTATIONS, EXPRESS OR IMPLIED, REGARDING TI RESOURCES OR USE THEREOF, INCLUDING BUT NOT LIMITED TO ACCURACY OR COMPLETENESS, TITLE, ANY EPIDEMIC FAILURE WARRANTY AND ANY IMPLIED WARRANTIES OF MERCHANTABILITY, FITNESS FOR A PARTICULAR PURPOSE, AND NON-INFRINGEMENT OF ANY THIRD PARTY INTELLECTUAL PROPERTY RIGHTS.

TI SHALL NOT BE LIABLE FOR AND SHALL NOT DEFEND OR INDEMNIFY YOU AGAINST ANY CLAIM, INCLUDING BUT NOT LIMITED TO ANY INFRINGEMENT CLAIM THAT RELATES TO OR IS BASED ON ANY COMBINATION OF PRODUCTS EVEN IF DESCRIBED IN TI RESOURCES OR OTHERWISE. IN NO EVENT SHALL TI BE LIABLE FOR ANY ACTUAL, DIRECT, SPECIAL, COLLATERAL, INDIRECT, PUNITIVE, INCIDENTAL, CONSEQUENTIAL OR EXEMPLARY DAMAGES IN CONNECTION WITH OR ARISING OUT OF TI RESOURCES OR USE THEREOF, AND REGARDLESS OF WHETHER TI HAS BEEN ADVISED OF THE POSSIBILITY OF SUCH DAMAGES.

You agree to fully indemnify TI and its representatives against any damages, costs, losses, and/or liabilities arising out of your non-compliance with the terms and provisions of this Notice.

This Notice applies to TI Resources. Additional terms apply to the use and purchase of certain types of materials, TI products and services. These include; without limitation, TI's standard terms for semiconductor products (<http://www.ti.com/sc/docs/stdterms.htm>), [evaluation modules](#), and [samples](http://www.ti.com/sc/docs/sampterm.htm) (<http://www.ti.com/sc/docs/sampterm.htm>).

Mailing Address: Texas Instruments, Post Office Box 655303, Dallas, Texas 75265  
Copyright © 2017, Texas Instruments Incorporated