

UNR6111/6112/6113/6114/6115/6116/6117/ 6118/6119/6110/611D/611E/611F/611H/611L (UN6111/6112/6113/6114/6115/6116/6117/6118/6119/ 6110/611D/611E/611F/611H/611L)

Silicon PNP epitaxial planer transistor

For digital circuits

Features

- Costs can be reduced through downsizing of the equipment and reduction of the number of parts.
- MT-1 type package, allowing supply with the radial taping.

Resistance by Part Number

	(R ₁)	(R ₂)
● UNR6111	10kΩ	10kΩ
● UNR6112	22kΩ	22kΩ
● UNR6113	47kΩ	47kΩ
● UNR6114	10kΩ	47kΩ
● UNR6115	10kΩ	—
● UNR6116	4.7kΩ	—
● UNR6117	22kΩ	—
● UNR6118	0.51kΩ	5.1kΩ
● UNR6119	1kΩ	10kΩ
● UNR6110	47kΩ	—
● UNR611D	47kΩ	10kΩ
● UNR611E	47kΩ	22kΩ
● UNR611F	4.7kΩ	10kΩ
● UNR611H	2.2kΩ	10kΩ
● UNR611L	4.7kΩ	4.7kΩ

Absolute Maximum Ratings (T_a=25°C)

Parameter	Symbol	Rated	Unit
Collector to base voltage	V _{CBO}	-50	V
Collector to emitter voltage	V _{CEO}	-50	V
Collector current	I _C	-100	mA
Total power dissipation	P _T	400	mW
Junction temperature	T _J	150	°C
Storage temperature	T _{stg}	-55 to +150	°C

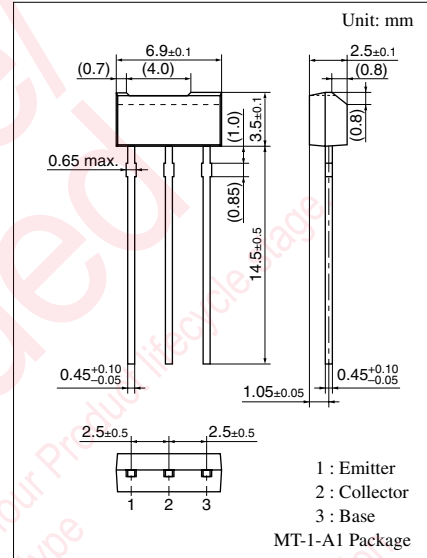

Internal Connection

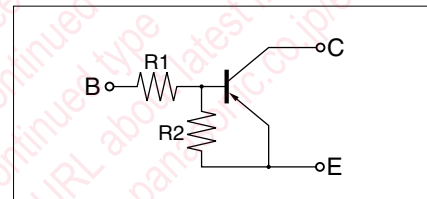

Note) The Part numbers in the Parenthesis show conventional part number.

UNR6111/6112/6113/6114/6115/6116/6117/
Transistors with built-in Resistor 6118/6119/6110/611D/611E/611F/611H/611L

■ Electrical Characteristics (T_a=25°C)

Parameter		Symbol	Conditions	min	typ	max	Unit
Collector cutoff current		I _{CBO}	V _{CB} = -50V, I _E = 0			-0.1	μA
		I _{CEO}	V _{CE} = -50V, I _B = 0			-0.5	μA
Emitter cutoff current	UNR6111	I _{EBO}	V _{EB} = -6V, I _C = 0			-0.5	mA
	UNR6112/6114/611E/611D					-0.2	
	UNR6113					-0.1	
	UNR6115/6116/6117/6110					-0.01	
	UNR611F/611H					-1.0	
	UNR6119					-1.5	
	UNR6118/611L					-2.0	
Collector to base voltage		V _{CBO}	I _C = -10μA, I _E = 0	-50			V
Collector to emitter voltage		V _{CEO}	I _C = -2mA, I _B = 0	-50			V
Forward current transfer ratio	UNR6111	h _{FE}	V _{CE} = -10V, I _C = -5mA	35			V
	UNR6112/611E			60			
	UNR6113/6114			80			
	UNR6115*/6116*/6117*/6110*			160		460	
	UNR611F/611D/6119/611H			30			
	UNR6118/611L			20			
Collector to emitter saturation voltage		V _{CE(sat)}	I _C = -10mA, I _B = -0.3mA			-0.25	V
Output voltage high level		V _{OH}	V _{CC} = -5V, V _B = -0.5V, R _L = 1kΩ	-4.9			V
Output voltage low level		V _{OL}	V _{CC} = -5V, V _B = -2.5V, R _L = 1kΩ			-0.2	V
			V _{CC} = -5V, V _B = -3.5V, R _L = 1kΩ			-0.2	
			V _{CC} = -5V, V _B = -10V, R _L = 1kΩ			-0.2	
			V _{CC} = -5V, V _B = -6V, R _L = 1kΩ			-0.2	
Transition frequency		f _T	V _{CB} = -10V, I _E = 1mA, f = 200MHz		80		MHz
Input resistance	UNR6111/6114/6115	R _I		(-30%)		(±30%)	10
	UNR6112/6117						22
	UNR6113/6110/611D/611E						47
	UNR6116/611F/611L						4.7
	UNR6118						0.51
	UNR6119						1
	UNR611H						2.2
Resistance ratio	UNR6111/6112/6113/611L	R ₁ /R ₂			0.8	1.0	1.2
	UNR6114				0.17	0.21	0.25
	UNR6118/6119				0.08	0.1	0.12
	UNR611D				3.7	4.7	5.7
	UNR611E				1.7	2.14	2.6
	UNR611F				0.37	0.47	0.57
	UNR611H				0.17	0.22	0.27

* h_{FE} rank classification (UNR6115/6116/6117/6110)

Rank	Q	R	S
h _{FE}	160 to 260	210 to 340	290 to 460

Common characteristics chart

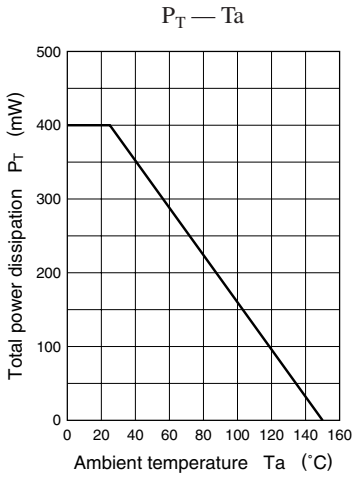

Characteristics charts of UNR6111

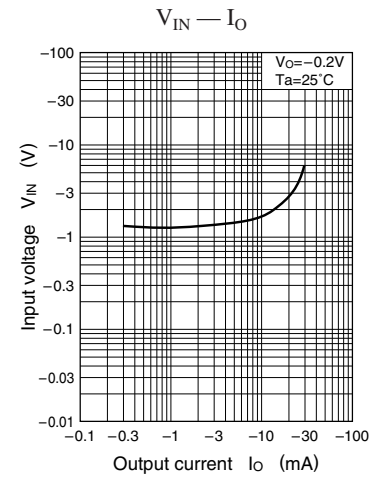
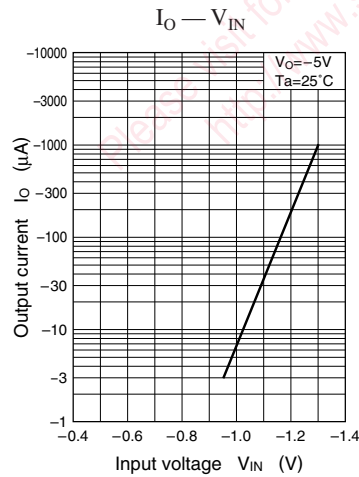
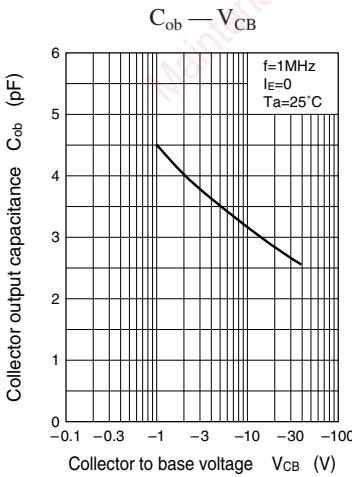
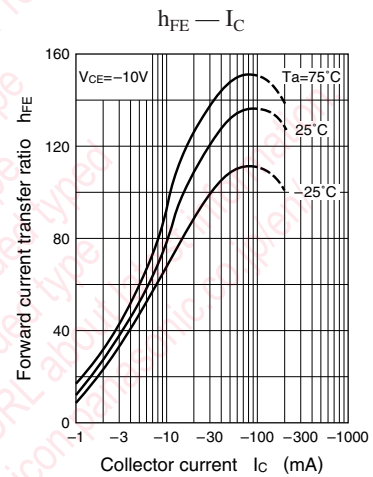
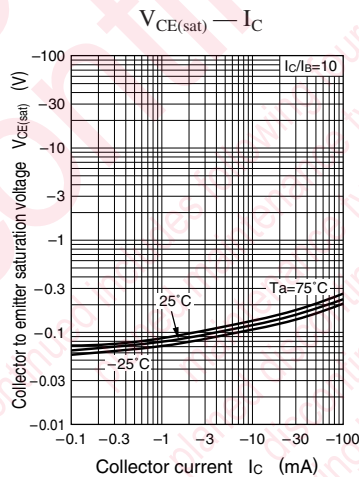
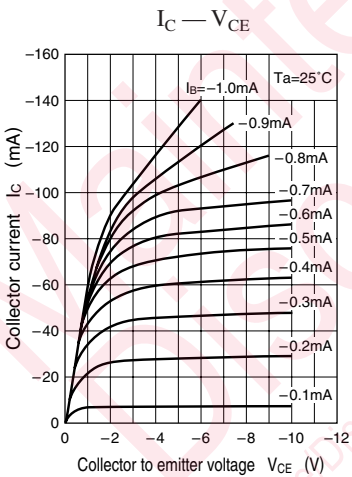

Characteristics charts of UNR6112

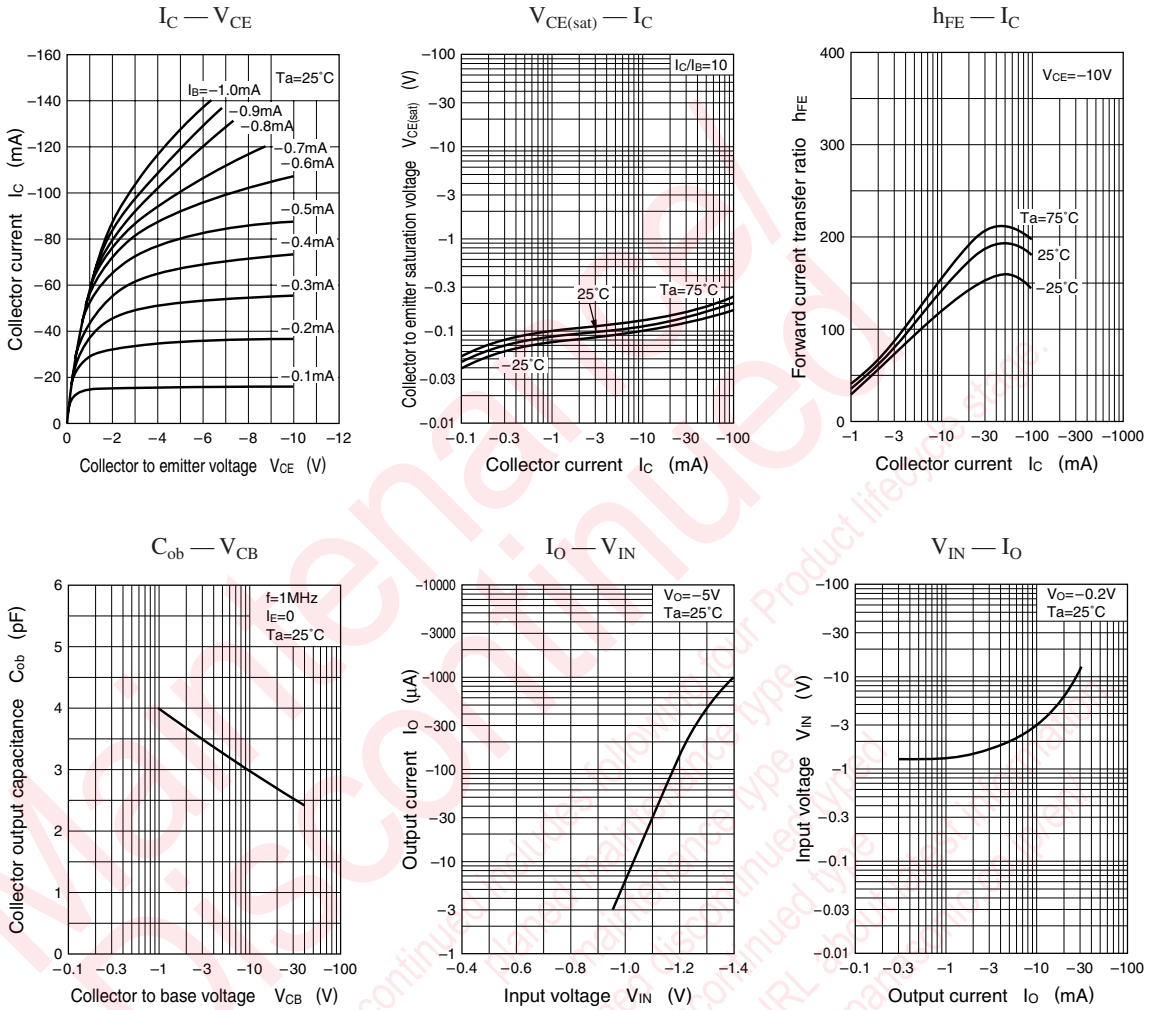

Characteristics charts of UNR6113

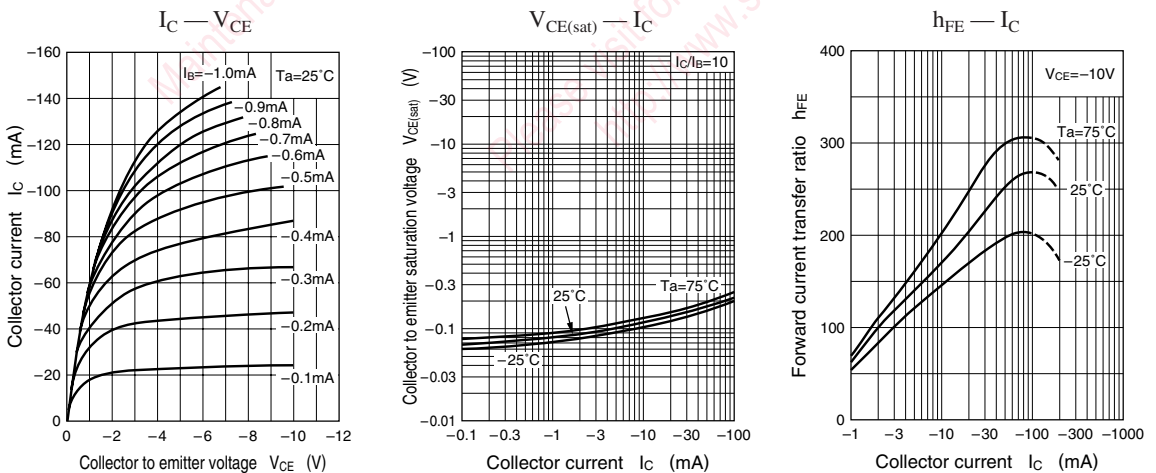

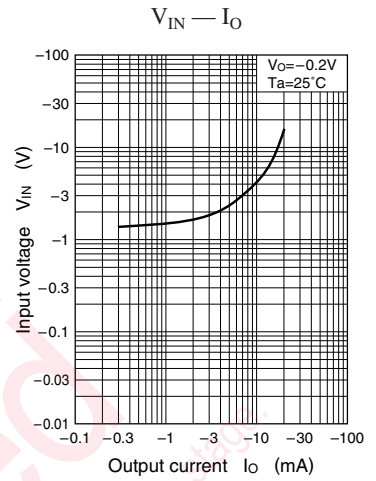
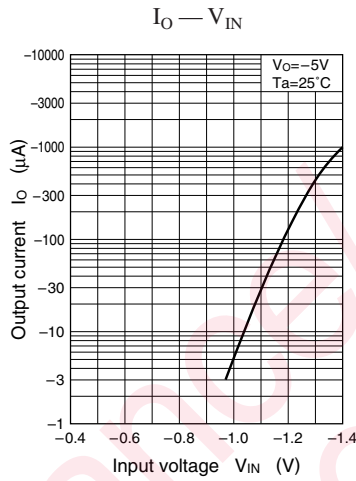
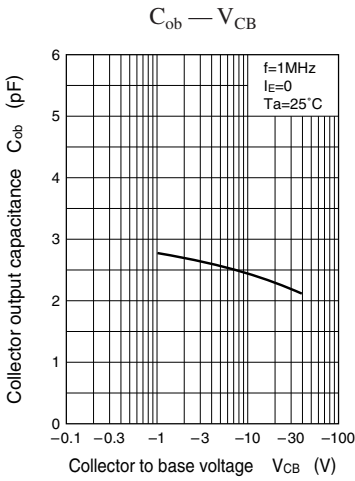

Characteristics charts of UNR6114

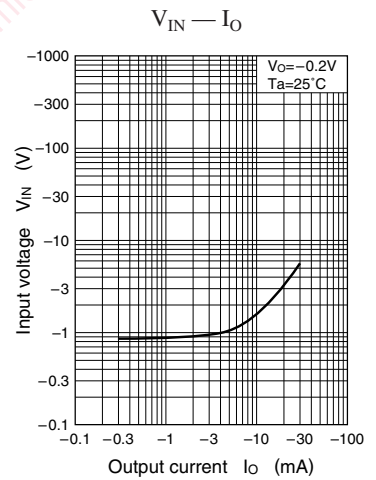
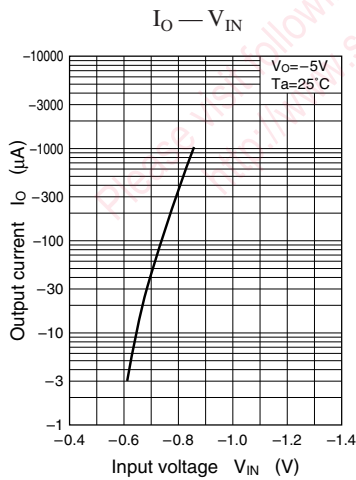
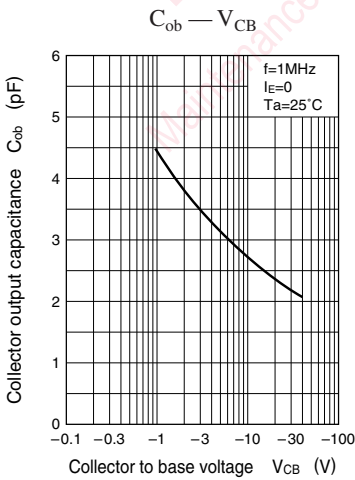
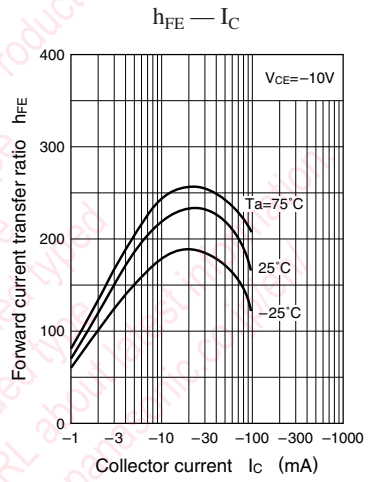
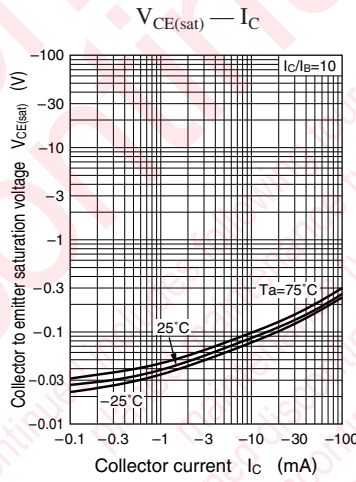
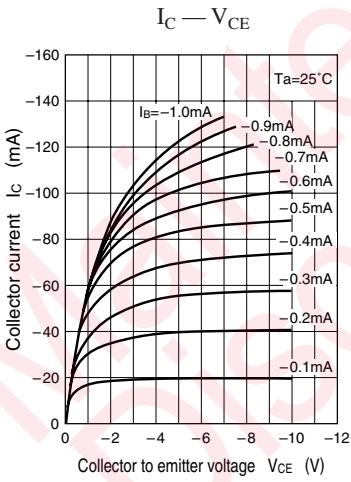

Characteristics charts of UNR6115

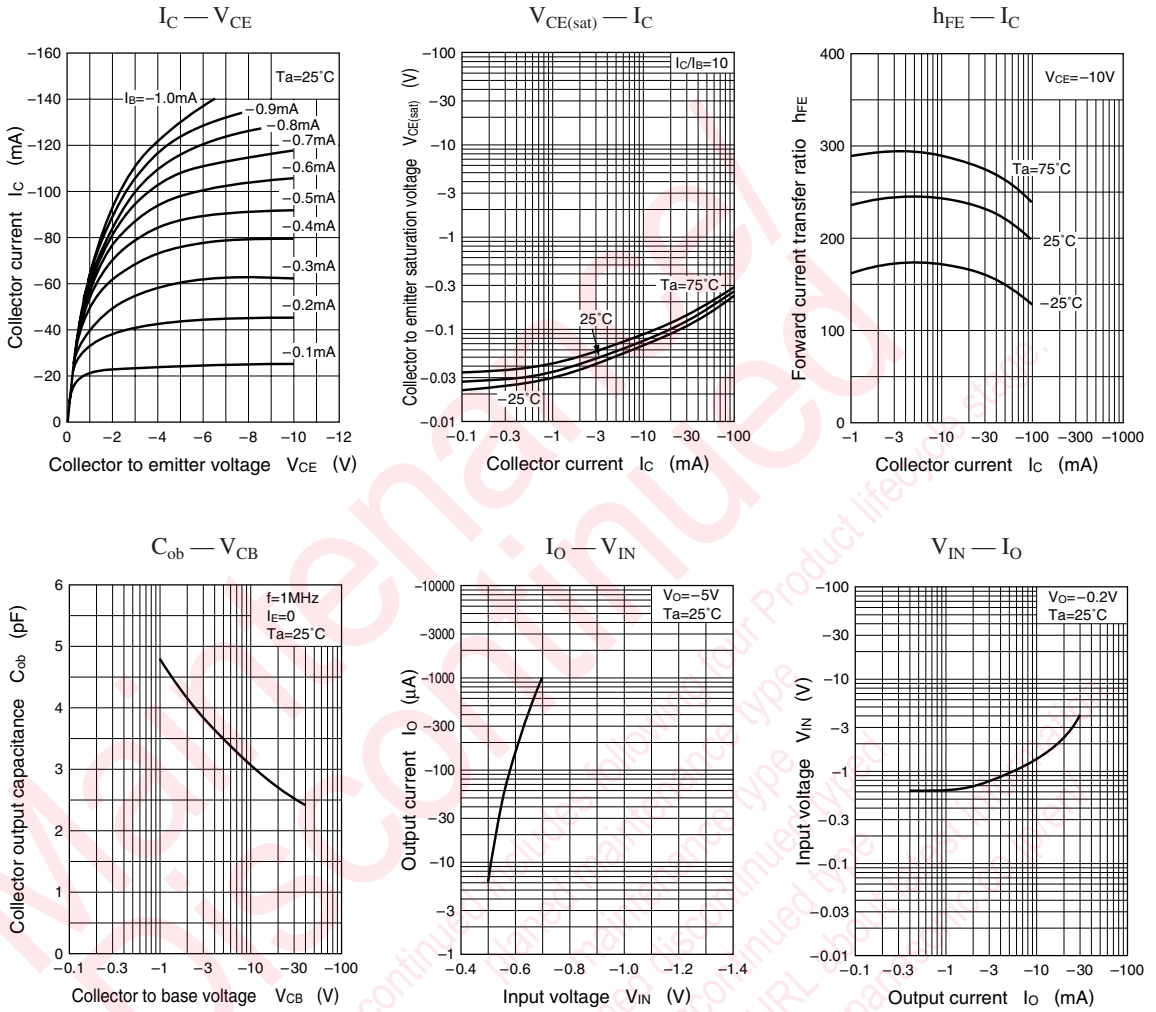

Characteristics charts of UNR6116

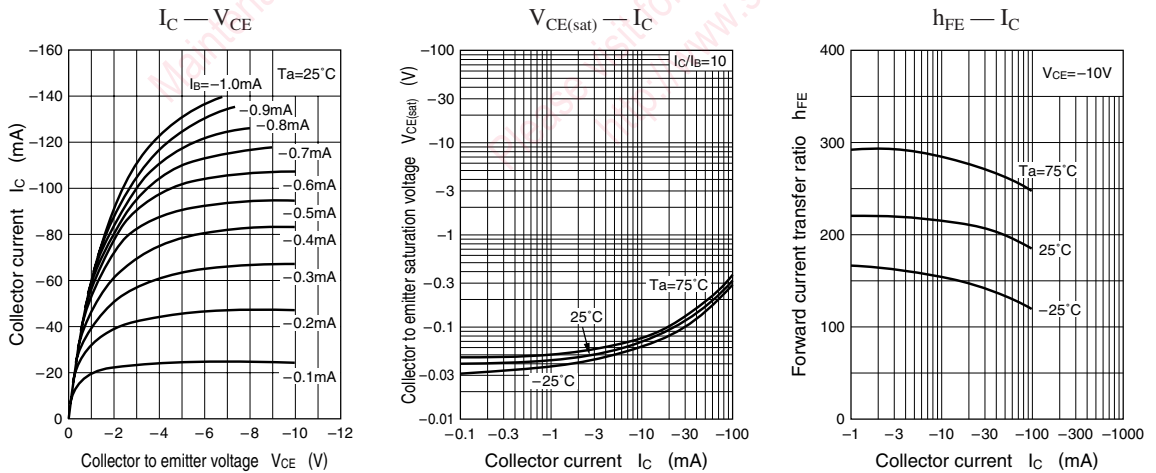

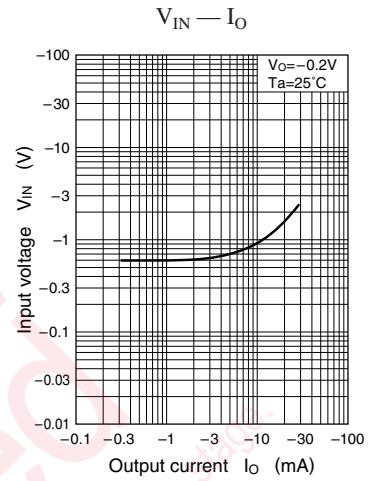
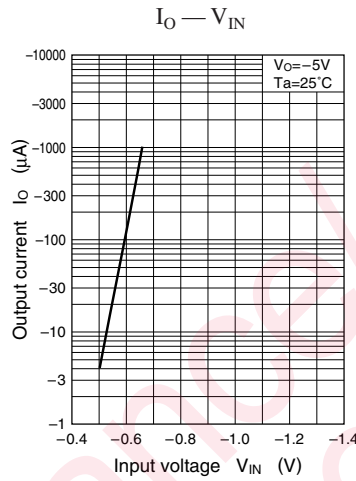
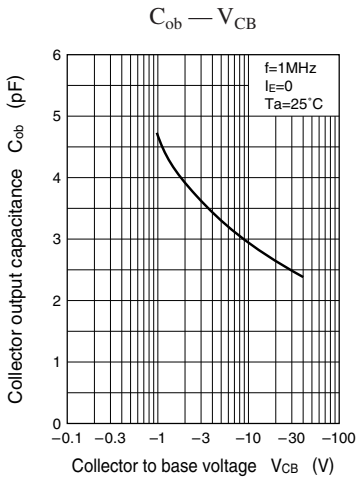

Characteristics charts of UNR6117

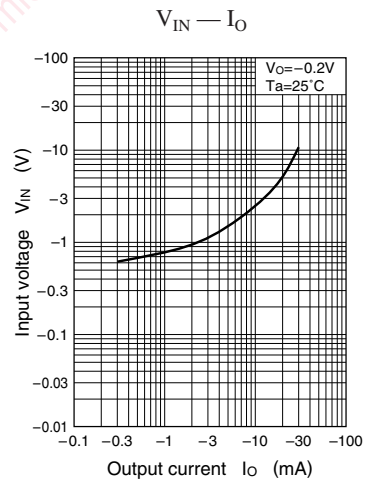
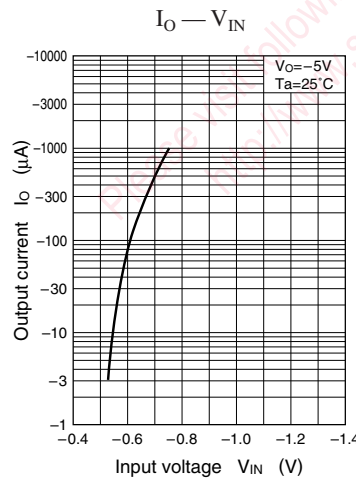
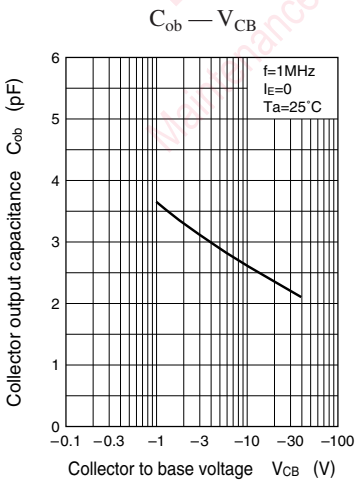
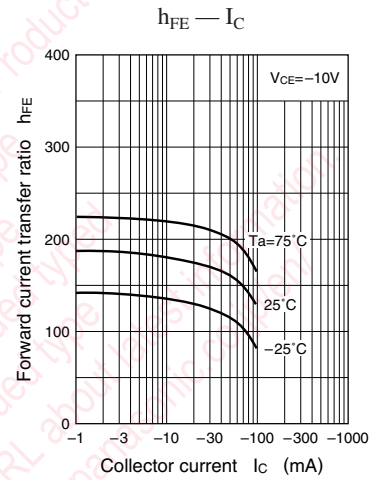
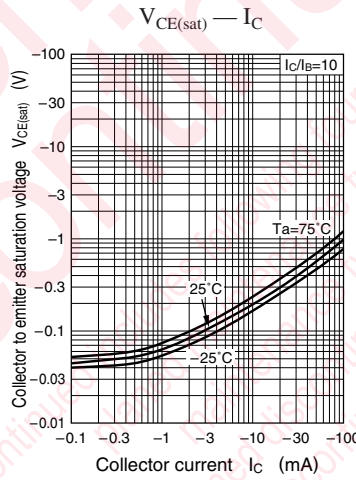
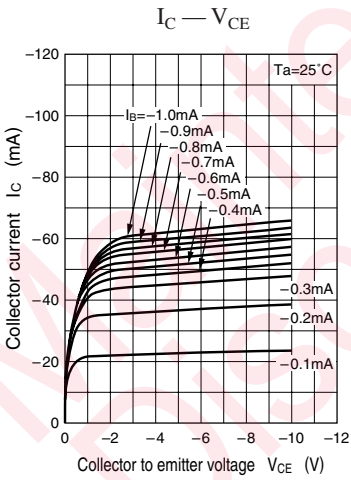

Characteristics charts of UNR6118

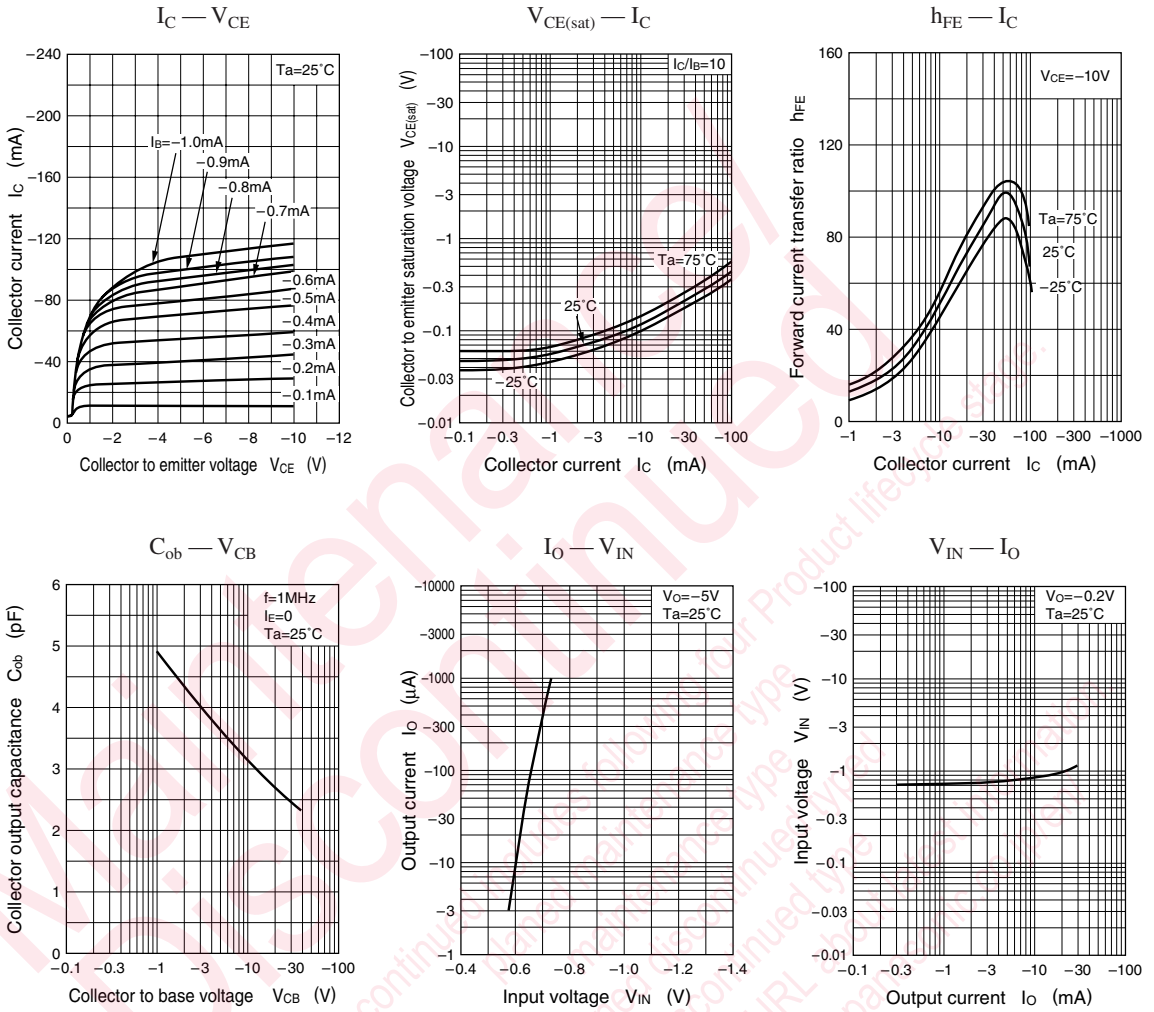

Characteristics charts of UNR6119

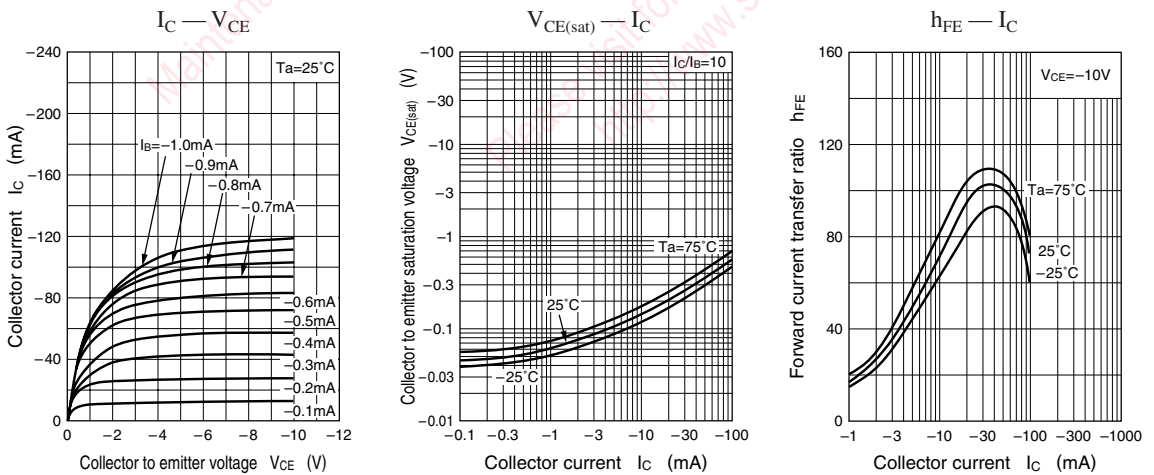

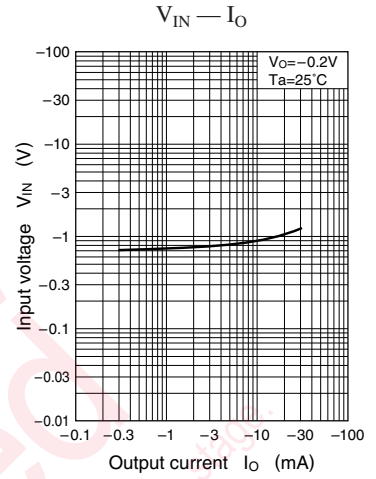
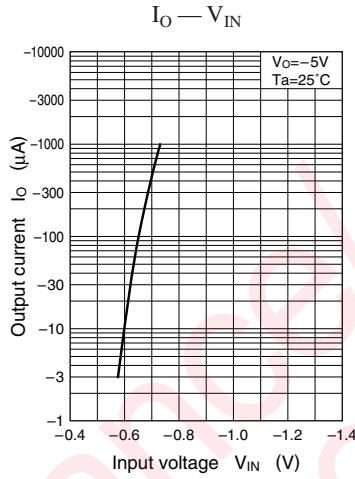
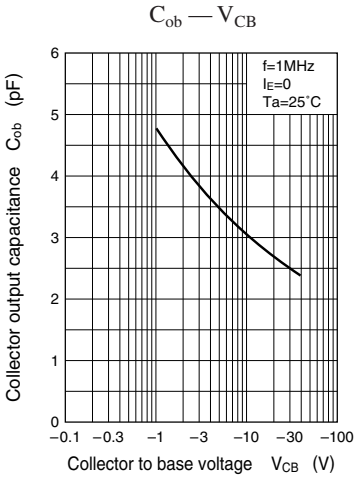

Characteristics charts of UNR6110

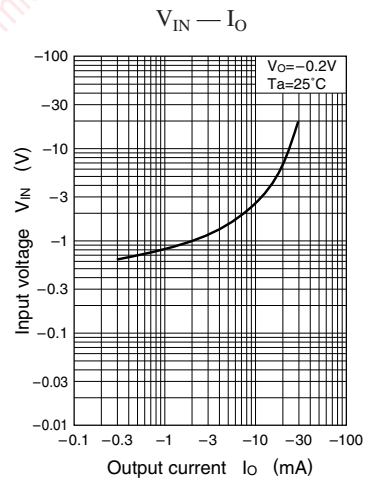
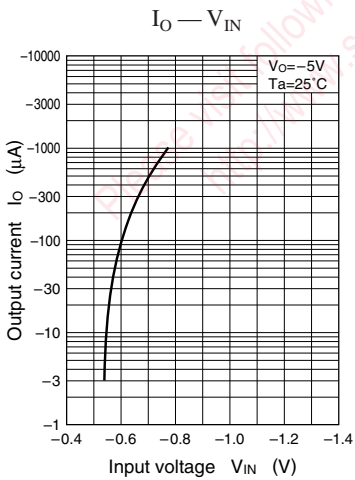
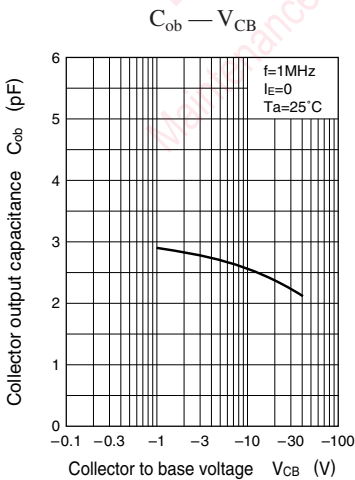
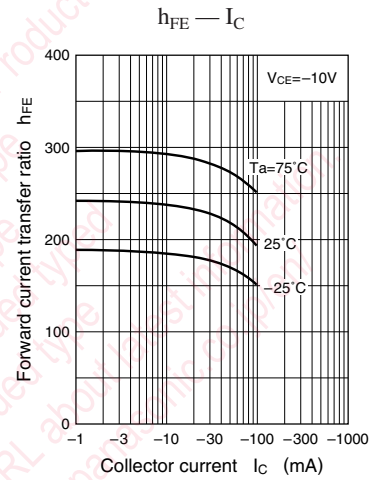
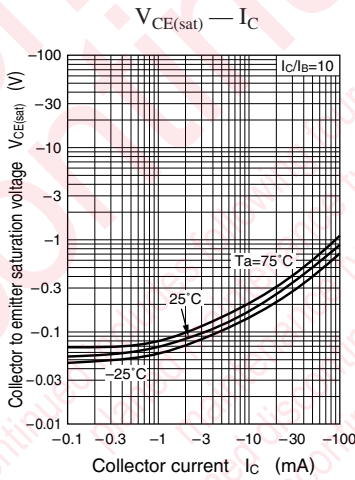
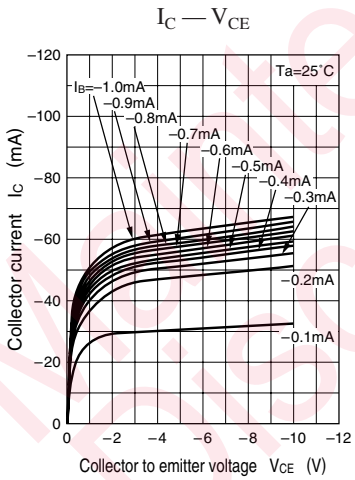

Characteristics charts of UNR611D

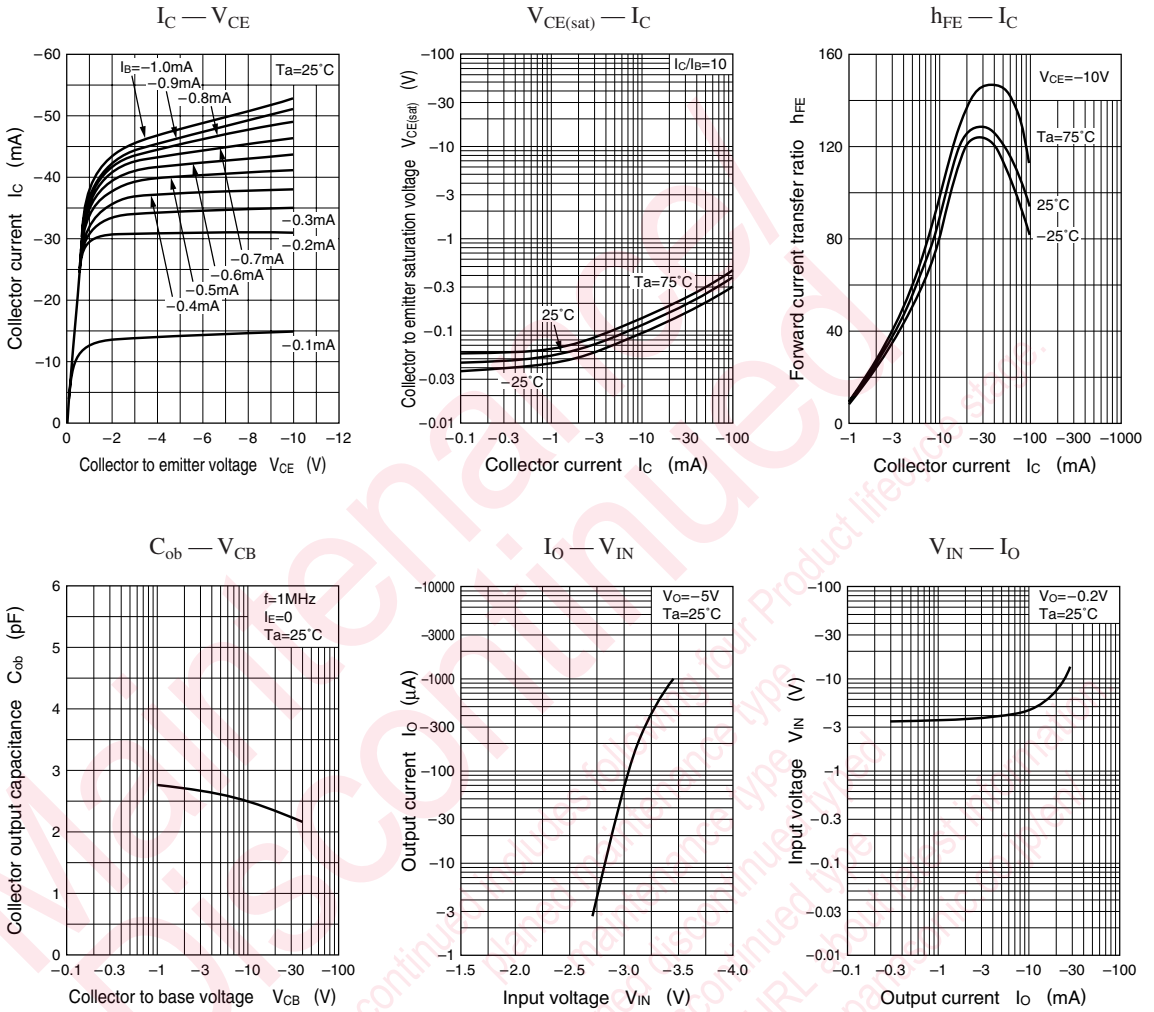

Characteristics charts of UNR611E

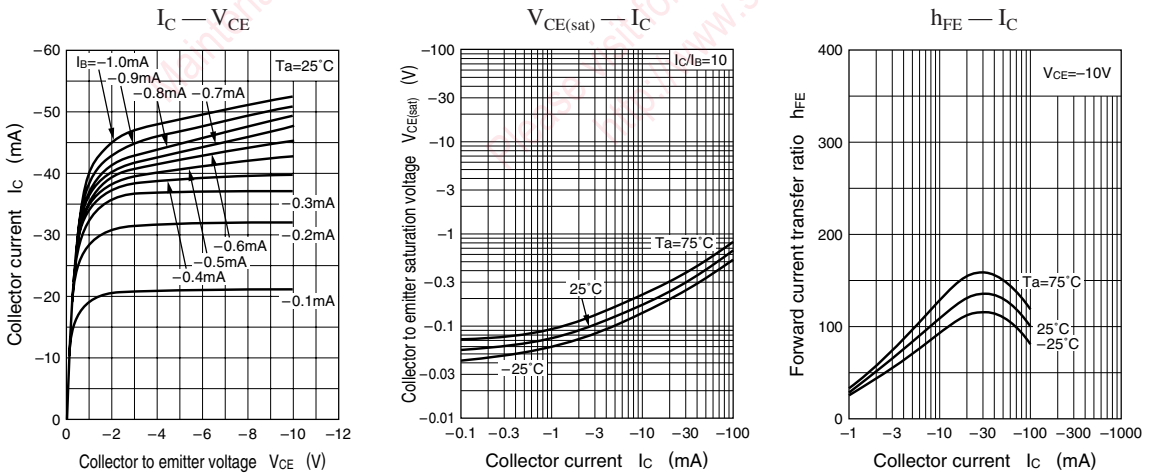

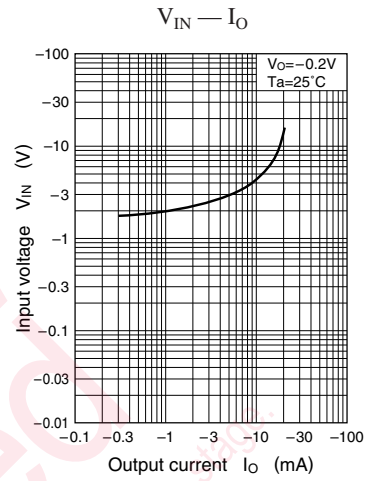
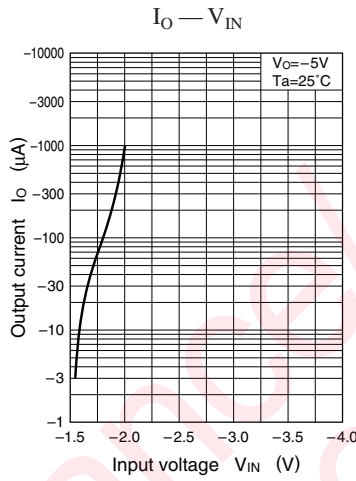
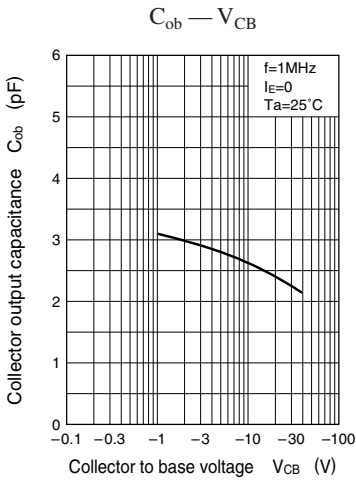

Characteristics charts of UNR611F

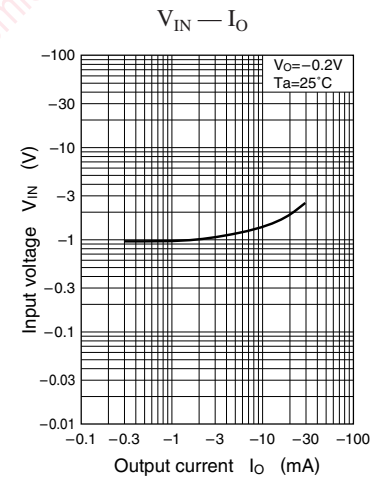
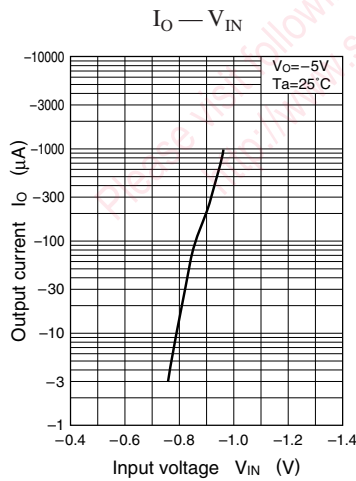
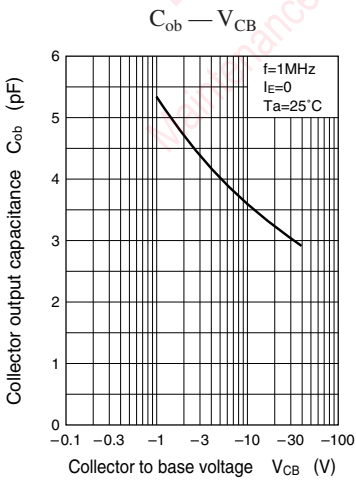
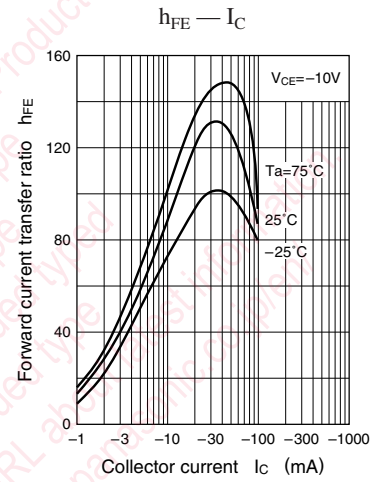
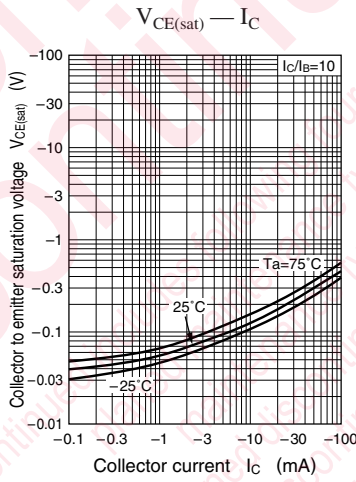
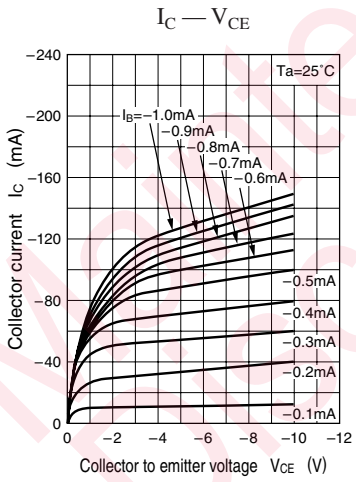

Characteristics charts of UNR611H

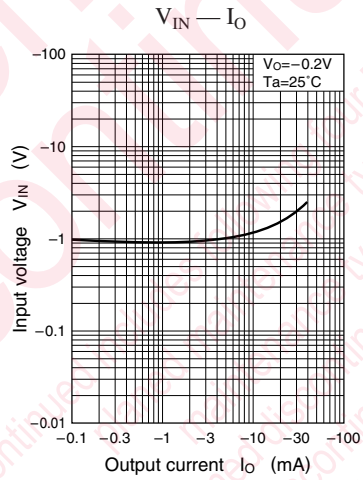
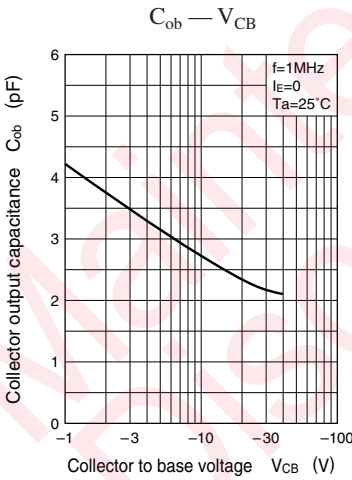
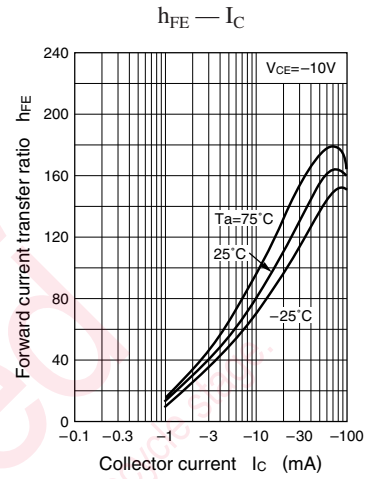
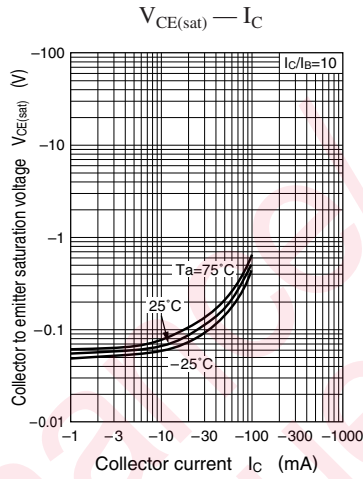
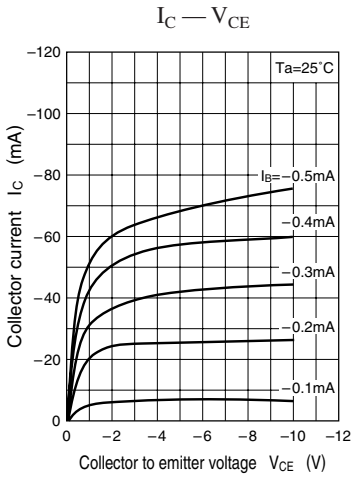

Characteristics charts of UNR611L

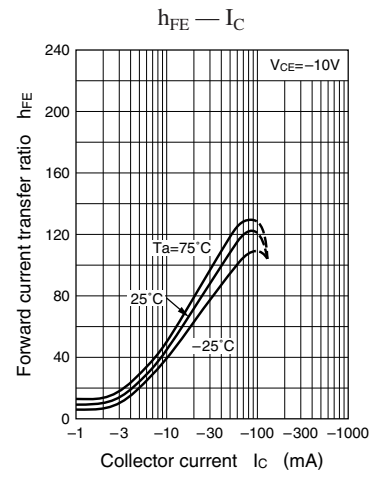
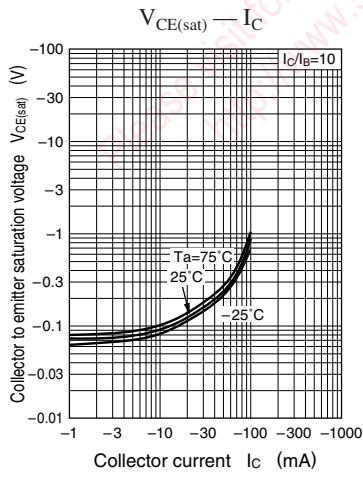
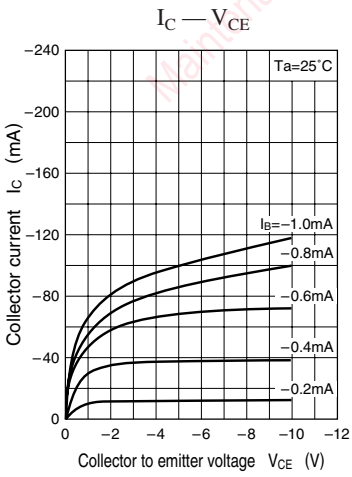

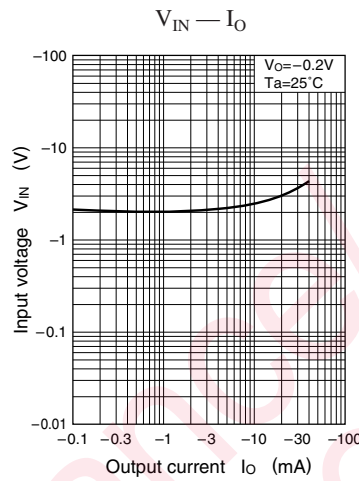
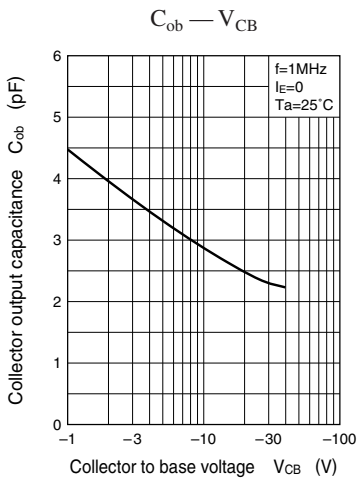

Maintenance/Discontinued

includes following four Product lifecycle stage.

- planned maintenance type
- maintenance type
- planned discontinued type
- discontinued type

Please visit following URL about latest information.

http://www.semicon.panasonic.co.jp/en/

Request for your special attention and precautions in using the technical information and semiconductors described in this book

- (1) If any of the products or technical information described in this book is to be exported or provided to non-residents, the laws and regulations of the exporting country, especially, those with regard to security export control, must be observed.
- (2) The technical information described in this book is intended only to show the main characteristics and application circuit examples of the products, and no license is granted under any intellectual property right or other right owned by our company or any other company. Therefore, no responsibility is assumed by our company as to the infringement upon any such right owned by any other company which may arise as a result of the use of technical information described in this book.
- (3) The products described in this book are intended to be used for standard applications or general electronic equipment (such as office equipment, communications equipment, measuring instruments and household appliances).
Consult our sales staff in advance for information on the following applications:
 - Special applications (such as for airplanes, aerospace, automobiles, traffic control equipment, combustion equipment, life support systems and safety devices) in which exceptional quality and reliability are required, or if the failure or malfunction of the products may directly jeopardize life or harm the human body.
 - Any applications other than the standard applications intended.
- (4) The products and product specifications described in this book are subject to change without notice for modification and/or improvement. At the final stage of your design, purchasing, or use of the products, therefore, ask for the most up-to-date Product Standards in advance to make sure that the latest specifications satisfy your requirements.
- (5) When designing your equipment, comply with the range of absolute maximum rating and the guaranteed operating conditions (operating power supply voltage and operating environment etc.). Especially, please be careful not to exceed the range of absolute maximum rating on the transient state, such as power-on, power-off and mode-switching. Otherwise, we will not be liable for any defect which may arise later in your equipment.
 - Even when the products are used within the guaranteed values, take into the consideration of incidence of break down and failure mode, possible to occur to semiconductor products. Measures on the systems such as redundant design, arresting the spread of fire or preventing glitch are recommended in order to prevent physical injury, fire, social damages, for example, by using the products.
- (6) Comply with the instructions for use in order to prevent breakdown and characteristics change due to external factors (ESD, EOS, thermal stress and mechanical stress) at the time of handling, mounting or at customer's process. When using products for which damp-proof packing is required, satisfy the conditions, such as shelf life and the elapsed time since first opening the packages.
- (7) This book may be not reprinted or reproduced whether wholly or partially, without the prior written permission of Matsushita Electric Industrial Co., Ltd.